

FELM



IE2

Motori elettrici ad alto rendimento
Energy efficiency





INTRODUZIONE

L'uso prudente e responsabile dell'energia per risparmiare risorse, per ridurre la quantità di emissioni di CO₂ e per diminuire i costi energetici, è all'ordine del giorno.

Il sistema di azionamento elettrico svolge un ruolo chiave in questo processo. Gli azionamenti elettrici costituiscono il legame tra la fornitura di energia elettrica e la maggioranza dei processi meccanici che richiedono una grande quantità di energia. Macchine azionate da motori elettrici consumano i due terzi di tutta l'energia elettrica utilizzata nell'industria. Se i vecchi sistemi nell'industria europea, nel commercio e nei servizi pubblici, che hanno funzionato per decenni venissero tutti sostituiti da moderni sistemi di azionamento, questo si tradurrebbe in un risparmio energetico annuo di 135 miliardi di chilowattora. Utilizzando il controllo elettronico della velocità e motori ad alta efficienza energetica, in Europa le emissioni di CO₂ potrebbero essere ridotte di 69 milioni di tonnellate.

Questa brochure descrive le nuove classi di rendimento internazionali normalizzate per i motori trifase standard, i nuovi metodi di misura e i requisiti stabiliti dal Regolamento Europeo 640/2009 della Commissione Europea per l'efficienza energetica dei motori e dei sistemi di azionamento. Offre inoltre una panoramica della legislazione nazionale in vigore in tutto il mondo e affronta temi come la composizione del materiale e il costo del ciclo di vita.

La brochure è scritta per gli utilizzatori, per gli OEM, per i costruttori di macchine e per i costruttori di motori e di sistemi di azionamento.



Classi di rendimento dei motori e metodi di misura

Il “rendimento” descrive come un motore elettrico trasformi efficientemente l’energia elettrica in energia meccanica. In precedenza in Europa, i motori trifase a bassa tensione sono stati classificati e commercializzati in tre classi di efficienza - EFF3, EFF2 e EFF1 - sulla base di un accordo volontario tra i produttori di motori e la Commissione Europea.

Questo sistema di classificazione è ben collaudato e ora è stato adattato in molti Paesi in tutto il mondo. Purtroppo, altri Paesi hanno anche sviluppato i propri sistemi nazionali, che sono molto diversi dal sistema europeo. Per questo motivo i produttori europei di motori del CEMEP hanno sviluppato uno standard di efficienza energetica per la Commissione Elettrotecnica Internazionale (IEC). L’obiettivo era quello di avere uno standard internazionale comune che sostituisse tutti i diversi sistemi nazionali. Questo progetto ha avuto successo e l’obiettivo è stato raggiunto.

La nuova Norma internazionale IEC 60034-30:2008 definisce le classi di rendimento IE1, IE2 e IE3 per motori trifase. Questo assicura una base comune internazionale per la progettazione e la classificazione dei motori, nonché per le attività legislative nazionali. Allo stesso tempo, la IEC ha sviluppato dei metodi migliorati per determinare il rendimento di questi motori. Le Norme internazionali IEC 60034-30:2008 (classificazione) e IEC 60034-2-1:2007 (metodi di misura) sono state adottate come norme europee, senza alcuna modifica, come EN 60034-30:2009 e EN 60034-2-1:2007. Per motivi di semplicità, le sezioni seguenti si riferiranno soltanto alle norme IEC.

Precedenti classi di efficienza dei motori in Europa

Nel 1998, come parte dell’accordo volontario tra il Comitato di settore europeo dei Costruttori di Macchine Elettriche ed Elettronica di Potenza (CEMEP) e la Commissione Europea, sono state definite tre classi di efficienza per la gamma di potenza da 1,1 kW a 90 kW:

EFF3 = Motori con un basso livello di efficienza;

EFF2 = Motori con un migliorato livello di efficienza;

EFF1 = Motori con un alto livello di efficienza.

Nuova Norma internazionale per le classi di rendimento dei motori (Codice IE)

L’accordo volontario è nel frattempo scaduto. Tuttavia, le classi di efficienza rimangono un marchio registrato europeo.

L’uso delle classi di efficienza si basa su un accordo di licenza contrattuale tra i partecipanti dell’accordo volontario (costruttori di motori) e il titolare della licenza (CEMEP / Gimélec). Questo accordo di licenza è scaduto il 10 febbraio 2010, ma può essere esteso al 15 giugno 2011 su richiesta.

La Norma IEC 60034-30:2008 definisce le classi di rendimento per i motori trifase a bassa tensione nella gamma di potenza da 0,75 kW a 375 kW. Il Codice “IE” sta per “Efficienza Internazionale” e si combina con un numero:

IE1 = Rendimento Standard;

IE2 = Rendimento Elevato;

IE3 = Rendimento Premium.

Nuovi metodi di misura IEC

I nuovi metodi di misura in conformità con la norma IEC 60034-201-1:2007 (metodi normalizzati per la determinazione, mediante prove, delle perdite e del rendimento) si applicano per tutti i motori descritti dalla norma IEC 60034-1. Questi metodi consentono di ottenere dati più precisi sulle perdite addizionali a carico. La nuova norma sostituisce la precedente Norma europea EN 60034-2:1996, che è scaduta il 1° novembre 2010.

I motori che vengono contrassegnati in base al nuovo sistema di classe di rendimento (Codice IE) devono essere sottoposti a prova utilizzando i nuovi metodi di misura.

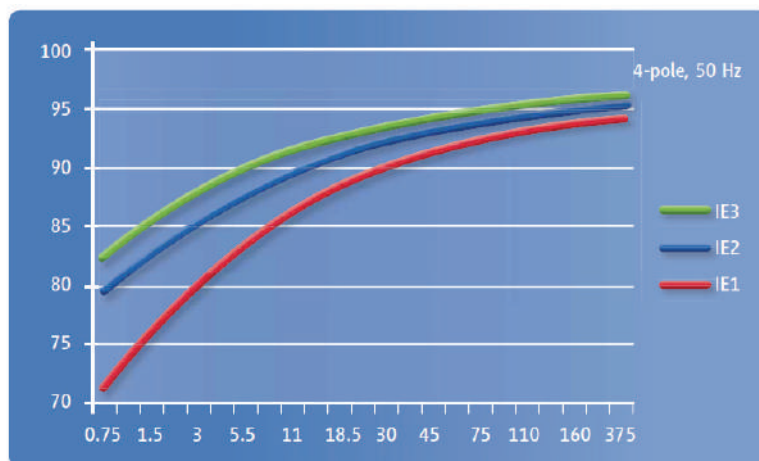



Confronto tra vecchie e nuove classi di rendimento

Il nuovo sistema internazionale di classi di rendimento (Codice IE) ha un metodo di numerazione aperto. Rispetto alle vecchie classi di efficienza EFF, è ora più facile aggiungere gli sviluppi futuri. Inoltre, vi è una nuova classe - IE3 - che non esisteva nel vecchio sistema europeo di classificazione EFF. Anche il campo di applicazione è stato esteso in modo significativo; il nuovo codice IE si applica a una gamma di potenza più ampia, così come per le classi a 60 Hz, come per esempio negli Stati Uniti.

La principale differenza tra le classi di rendimento (EFF e IE) sta nel metodo utilizzato per determinarle. In un confronto diretto per lo stesso motore, ci si aspetta che il rendimento determinato secondo il nuovo metodo di misura sia più basso. Ad esempio, un motore EFF1 a 4 poli di 11 kW con il 91,0% di rendimento è fisicamente identico a un motore IE2 con l'89,8% di rendimento.

Campo di applicazione del nuovo sistema di classi di rendimento IEC (Codice IE)

Il sistema di classi di rendimento specificato nella IEC 60034-30 è applicabile per motori asincroni trifase, a 50 Hz e 60 Hz, con rotore a gabbia a una sola velocità con le seguenti caratteristiche:

- Tensione nominale fino a 1000 V;
- Potenza nominale compresa tra 0,75 kW e 375 kW;
- 2, 4 o 6 poli;
- Targati o in base al tipo di servizio S1 (servizio continuo) o S3 (servizio intermittente periodico) con un rapporto di intermittenza nominale uguale o superiore all'80%;
- In grado di funzionare collegati direttamente alla linea di alimentazione;
- Adatti per le condizioni di funzionamento secondo la IEC 60034-1, art. 6.

I motori con flange, piedi e/o alberi di dimensioni meccaniche diverse da quelle stabilite nella IEC 60072-1 rientrano nella presente norma.

I motoriduttori e i motori autofrenanti rientrano nella presente norma, sebbene in tali motori possano essere utilizzati alberi e flange speciali.

Alcuni motori elettrici inclusi nella presente norma possono essere dotati di dispositivi ausiliari. Tuttavia, finché questi dispositivi ausiliari non costituiscono parte integrante del motore, non è pratico determinare il rendimento in tutte le combinazioni possibili. Le prove relative al rendimento di tali motori di serie modificati devono essere effettuate su motori base senza dispositivi ausiliari installati.

Sono esclusi dal sistema di classificazione:

i motori per breve tempo di funzionamento (servizio S2) o per operazioni di commutazione (servizio da S3 con rapporto di intermittenza nominale

< 80% a S10);

- i motori realizzati solo per funzionamento con convertitore in accordo con la IEC 60034-25;

- i motori completamente integrati in una macchina (per es. pompe, ventilatori e compressori) che non possono essere provati separatamente dalla macchina.





INTRODUCTION

The conservative and responsible use of energy to save resources, to reduce the amount of CO₂ emissions and to decrease energy costs is the order of the day. The electrical drive system plays a key role in this process. Electrical drives form the link between the electrical energy supply and the majority of mechanical processes, which require a large amount of energy. Machines driven by electrical motors consume 2/3 of all the electrical energy used in industry. If the old systems in German industry, commerce and public facilities, which have been running for decades, were all replaced by modern drive systems, this would result in annual energy savings of 38 billion kilowatt hours. Calculated for all of Europe, this figure would be 135 billion kilowatt hours. By using energyefficient motors, Europe's CO₂ emissions could be reduced by 69 million tonnes. This brochure describes the new standardised international efficiency classes for standard three-phase motors, the new measuring methods and the requirements stipulated by the European Regulation 640/2009 of the European Commission for energy efficiency in motors and drive systems. This brochure also offers an overview of some of the world-wide existing national legislation and addresses subjects like material composition and life cycle cost. The brochure is written for users, original equipment manufacturers (OEM), machine manufacturers and motor and drive system manufacturers.



Efficiency Classes of Motors and Measuring Methods

The „efficiency“ describes how efficiently an electric motor transforms electrical energy into mechanical energy. Previously in Europe, low voltage three-phase motors have been graded and marketed in three efficiency classes – EFF3, EFF2 and EFF1 – based on a voluntary agreement between motor manufacturers and the European Commission. This classification system is well proven and has now been adapted in many countries around the world. Unfortunately, other countries have also developed their own national systems, which are very different from the European system. That was the reason for the

German motor manufacturers in ZVEI, with the support of their European neighbours, to develop an energy efficiency standard for the International Electrotechnical Commission (IEC).

The objective was to have a common international standard that replaces all the different national systems.

This project was successful and the objective has been met.

The new international standard, IEC 60034-30:2008, defines efficiency classes IE1, IE2 and IE3 for three-phase motors. This ensures a common international basis for the design and classification of motors as well as for national legislative activities. At the same time, the IEC developed improved methods for determining the efficiency of these motors.

The international standards IEC 60034-30:2008 (classification) and IEC 60034-2-1:2007 (measuring methods) have been adopted as European standards without any changes as EN 60034-30:2009 and EN 60034-2-1:2007. For the sake of simplicity, the following sections will refer to the IEC standards only.

Previous efficiency classes of motors in Europe

In 1998, as part of the voluntary agreement between the European sector committee of Manufacturers of Electrical Machines and Power Electronics (CEMEP) and the European Commission, three efficiency classes were defined for the power range of 1.1 kW to 90 kW:

- EFF3 = Motors with a low efficiency level
- EFF2 = Motors with an improved efficiency level
- EFF1 = Motors with a high efficiency level

New international standard for efficiency classes of motors (IE-code)

This voluntary agreement has since expired. However, the efficiency classes remain a registered European trademark. Use of the efficiency classes is based on a contractual licensing agreement between the participants in the voluntary agreement (motor manufacturers) and the license holder (CEMEP / Gimelec). This licensing agreement expires on 10 February 2010, but can be extended to 15 June 2011 upon request.

Standard IEC 60034-30:2008 defines the efficiency classes for low voltage three-phase motors with a power range from 0.75 kW to 375 kW. “IE” stands for “International Efficiency” and is combined with a number:

- IE1 = Standard efficiency
- IE2 = High efficiency
- IE3 = Premium efficiency

New IEC measuring methods

The new measuring methods in accordance with IEC 60034-2-1:2007 (standard methods for determining losses and efficiency from tests) apply for all motors described by IEC 60034-1. These methods help to generate more exact data regarding stray load loss. The new standard replaces the previous European standard EN 60034-2:1996, which expired on 1 November 2010.

Motors that are marked according to the new efficiency class system (IE-code) are required to be measured using the new measurement methods.

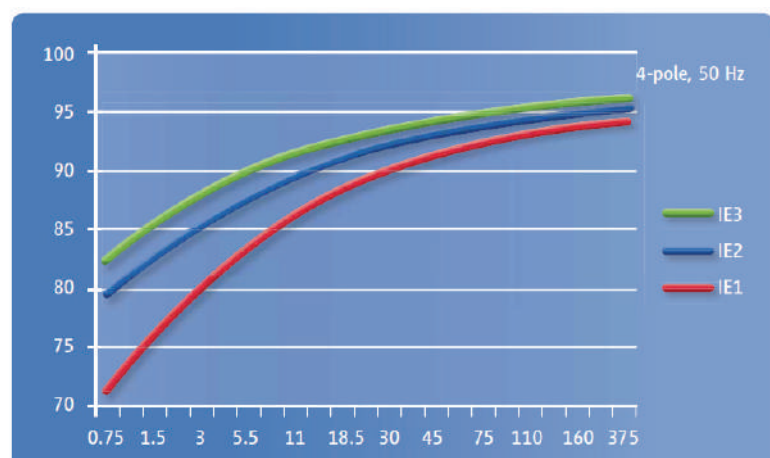

Comparison of old and new efficiency classes



The new international efficiency class system (IE-code) has an open numbering system. Compared to the old EFF efficiency classes, it is now easier to add future developments. In addition, there is a new class – IE3 – which did not exist in the old European EFF classification system.

The scope has also been extended significantly; the new IE-code applies to a larger power range as well as for the 60 Hz classes e.g. in the USA.

The main difference between the efficiency classes (EFF and IE) lies in the method used to determine them. In a direct comparison at the same motor, it is expected that the efficiency determined according to the new measuring method will be lower. For example, an 11 kW, 4-pole EFF1 motor with 91.0% efficiency is physically identical with a IE2 motor with 89.8% efficiency.

Scope of new IEC efficiency class system (IE-code)

The efficiency class system specified under IEC 60034-30 is valid for low voltage three-phase cage induction motors with the following specifications:

- Rated voltage up to 1,000 V
- Rated output between 0.75 kW and 375 kW
- Either 2, 4 or 6 poles
- Rated on the basis of continuous duty (S1) or intermittent periodic duty (S3) with cyclic duration factor of 80% or higher;
- Capable of operating direct on-line
- Rated for operating conditions in accordance with IEC 60034-1 (temperature, installation altitude, etc.)

Motors with flanges, feet and/or shafts with mechanical dimensions different from IEC 60072-1 are covered by this standard.

Geared motors and brake motors are covered by this standard, although special shafts and flanges may be used in such motors.

Some motors covered by this standard may be equipped with auxiliary devices. However, as long as these auxiliary devices are not an integral part of the motor construction, the determination of efficiency in all possible combinations is not practical. Determinations for efficiency of such modified standard motors shall be performed on basic motors without auxiliary devices installed.

The following are exceptions to the classification system:

- Motors for short-time duty (S2) or switching operation (S3 < 80% to S10);
- Motors that were solely designed for converter operation (VSD) in accordance with IEC 60034-25 as well as
- Motors that have a highly specialised design customised for one particular application in such a way that it is not possible to measure the motor on its own (for example pump motors with wet rotors).

FELM opera nel settore dei motori elettrici dal 1960 e possiede un background consolidato nel mercato delle macchine elettriche.

Grazie all'esperienza e alla specializzazione del proprio personale può garantire un supporto tecnico in grado di rispondere anche alle più sofisticate esigenze di installazioni e di manutenzione, garantendo un Service Internazionale alla propria clientela.

I nostri uffici e magazzini si estendono su una superficie di oltre 10.000 mq.

Il vasto stock di Motori Elettrici da 0,12 a 800 KW, nelle differenti polarità e il capillare servizio di distribuzione sono i punti di forza che permettono a FELM di garantire consegne celeri in Italia e in tutta Europa

Una particolare attenzione è riservata al Processo Produttivo in fabbrica:

- dall'esecuzione degli avvolgimenti (attraverso una selezione accurata dei materiali, rame e isolanti)
- al controllo dei processi di impregnazione e polimerizzazione (VPI Vacuum Pressure Impregnation)
- fino alla verifica della qualità dei cuscinetti impiegati (per garantire una migliore prestazione del motore e una durata superiore allo standard)

FELM offre:

- standard qualitativi elevati e comprovati dalla Certificazione ISO 9001 ICIM Certificate 2508/2
- Produzione di Motori Elettrici Standard e Speciali su specifiche del cliente
- Commercializzazione di Motori Elettrici e relativi accessori elettrici o elettronici

Gamma dei Motori Elettrici offerti:

- Standard a Bassa Tensione IC 411, IC 611, IC 86W
- EFF 1 Nuove classi di rendimento internazionali dei motori - Codici IE
 - nuova norma IEC 60034-30:2008 che stabilisce le classi di rendimento
 - IE1 = rendimento standard (paragonabile a EFF2)
 - IE2 = alto rendimento (paragonabile a EFF1)
 - IE3 = Premium Efficiency
- Media Tensione 3, 6, 11 kV. IC 411, IC 611, IC 86W
- Idonei a funzionamento con Inverter (400 V, 690 V, 3 e 6 KV)
- Ad Anelli con rotore avvolto
- Antideflagranti: Ex d, n
- NEMA, UL, CSA, EPACT
- GOST, Marine Classifying authority (RINA, Lloyd Register, DNV, ABS, BV, ecc)



MOTORI ELETTRICI ASINCRONI TRIFASE IP55

CARATTERISTICHE GENERALI

I motori asincrono trifase a gabbia FELM sono in conformità alle seguenti norme:

IEC (International Electrotechnical Commission) 60034-1.
Elettriche: IEC/EN 60034-1, IEC/EN60034-2-1, IEC 60034-8, IEC 60034-12, IEC/EN 60034-9, IEC 60034-14, IEC 60034-30
Meccaniche: IEC 60072, IEC/EN 60034-5, IEC/EN 60034-6, IEC/EN 60034-7, IEC/EN 60034-9, IEC/EN 60034-14.

UNEL, le normative UNEL sono in accordo alla normative IEC internazionali.

Le caratteristiche principali sono le seguenti:

- Costruzione robusta Carcassa e scudi in lega di alluminio fino alla grandezza 132 e piedini smontabili. Questa soluzione permette la rotazione della carcassa, con il posizionamento della scatola morsettiere a destra o sinistra vista lato accoppiamento.
- Carcassa e scudi in ghisa per le grandezze 160 / 560. I piedini sono fissi alla carcassa. Su richiesta i motori possono essere forniti con scatola morsettiere a destra o sinistra, vista lato accoppiamento.
- Design moderno.
- Elevata coppia di spunto.
- Alta efficienza "IE" per il massimo risparmio energetico.
- 2, 4, 6 poli soddisfano o superano la massima efficienza richiesta dalle nuove normative IEC:

IEC 60034-2-1 criteri che definiscono i metodi di prova relativi al calcolo dell'efficienza.
IEC 60034-30 nuove classi di efficienza dei motori.

- Grado di protezione IP55 standard
 - Servizio continuo S1
 - Basso livello di rumorosità.
- L'utilizzo dei migliori materiali per la costruzione, ci ha permesso di raggiungere motori con ottime caratteristiche elettriche e meccaniche. La gamma dei motori FELM è ideale per applicazioni gravose che richiedono un'elevata resistenza meccanica e possono essere prodotti per qualsiasi tensione e/o frequenza non standard.
- Felm, oltre ai motori standard, fornisce le seguenti varianti:
- a - motori 2 o 3 velocità con coppia costante o per ventilatori / pompe.
 - b - ventilazione forzata per applicazioni a velocità variabile.
 - c - motori con trattamento di tropicalizzazione speciale, destinati l'uso in climi tropicali umidi.
 - d - motori antideflagranti EExd conformi agli standard ATEX.

INTERPRETAZIONE DELLA SIGLA MOTORE (Esempio)

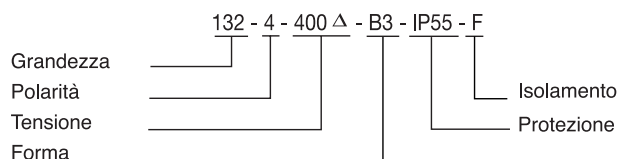

CONDIZIONI DI SERVIZIO

I motori Felm sono costruiti per funzionare ad una temperatura ambiente da -20 °C a 40 °C (con temperatura di surriscaldamento in classe B) e altitudini fino a 1000 metri sul livello del mare. Su richiesta è possibile fornire motori adatti a temperature ambiente e altitudini al di sopra delle condizioni standard.

GAMMA POTENZA RESA

2 poli - 0,18 ÷ 1000 KW
4 poli - 0,12 ÷ 1500 KW
6 poli - 0,06 ÷ 1500 KW
8 poli - 0,18 ÷ 1200 KW

VOLTAGGIO E FREQUENZA

Tensione normale (MULTITENSIONE) V. 230 Δ / V. 400 Δ o 690 Δ
Collegamento Δ per motori fino a 3kW
Collegamento Δ per motori oltre a 4kW
Frequenza 50 Hz con possibilità di impiego a 60 Hz

STATORE

Gli avvolgimenti dello statore hanno un doppio trattamento di impregnazione che lo rende un corpo unico e solido per dare buone caratteristiche di resistenza meccanica e altamente resistente all'umidità e stress termici.

La classe di isolamento F, con una sovratemperatura di classe B (80 °C), fornisce un margine di sicurezza eccezionale e garantisce una più lunga vita termica anche in condizioni di funzionamento "anomalo".

ROTORE

Il rotore è realizzato con Alluminio di pressofusione, è forzato sull'albero a freddo o calettato a caldo ed è dinamicamente bilanciato (con mezza chiave) in accordo alla normativa IEC 60034-14.

VENTOLA E COPRIVENTOLA

I motori, in esecuzione standard, sono caratterizzati dal metodo di raffreddamento IC 411 (in accordo alla IC 60034-6) e con ventola bidirezionale.

I motori possono essere forniti su richiesta con metodo di raffreddamento, in IC 416 (ventilazione forzata).

La Ventilazione forzata è progettata per un raffreddamento ottimale anche a bassa velocità.

CUSCINETTI

I motori Felm sono equipaggiati con cuscinetti SKF o primarie marche adatti all'uso richiesto, a sfere o a rulli, lubrificati a grasso.

I motori serie FA2 (alluminio) e F2 (ghisa) grandezze 63 - 225 montano cuscinetti a sfere stagni (longlife), o cuscinetti a rulli su richiesta.

I motori FELM serie F2 (ghisa) montano cuscinetti a sfere (o a rulli su richiesta) dalla grandezza 250 lubrificati mediante ingrassatore sia lato accoppiamento sia lato opposto. Per questi motori è previsto un ingrassaggio periodico come riportato nel manuale uso manutenzione e/o sulla targia apposta sul motore.

SCATOLA MORSETTIERA

Per le forniture standard, la scatola morsettiere è montata:

- grandezza 63 ÷ 132 sulla parte superiore della carcassa ruotabile, come riportato nelle note precedenti.

- grandezza 160 ÷ 450 sulla parte superiore della carcassa e su richiesta la Scatola morsettiere può essere montata lateralmente.

L'orientamento indicato è riferito al motore guardato dal lato albero.

La Scatola morsettiere è provvista di pressacavo e può essere orientata di 90° in 90°, per ottenere l'entrata ottimale dei cavi di alimentazione.

Dalla grandezza 160 tutti i motori sono equipaggiati di una Termoresistenza PTC, con i terminali nella scatola morsettiere principale.

VIBRAZIONI

Le vibrazioni dei motori a vuoto sono indicate nella tabella che segue:
Bilanciati con mezza chiave secondo la normativa IEC 60034-143

Grandezza (mm)	63•132	160•225	250•355
Velocità di vibrazione (mm/sec)	1,8	2,8	4,5

Valori garantiti vengono rilasciati su richiesta.

PROTEZIONE PER AMBIENTI TROPICALI/AGGRESSIVI

SUPERFICI ESTERNE

Per una migliore resistenza agli ambienti caldi e umidi, agli agenti chimicamente aggressivi ed alla atmosfera salina possono essere forniti, su richiesta, motori con particolari trattamenti sulle superfici metalliche esterne. Per questi motori la verniciatura sarà effettuata con smalti ad elevate caratteristiche contro la corrosione, su richiesta è possibile fornire viteria INOX.

AVVOLGIMENTI

Gli avvolgimenti dei motori FELM sono tropicalizzati di serie usando vernici antiflash.

PROTEZIONE TERMICA

I motori FELM montano di serie dalla grandezza 160 termorivelatori a termistori PTC negli avvolgimenti (relé di alimentazione non di nostra fornitura). A richiesta i motori FELM possono essere equipaggiati con termoprotettori PT100, protettori bimetallici Klixon (normalmente chiusi) e scaldiglie anticondensa, nonché PT100 sui cuscinetti.

VERNICIATURA

I motori FELM sono verniciati standard con colore blu RAL 5010. Su richiesta si possono effettuare verniciature non standard con percentuali aggiuntive.

DECLASSAMENTO PER ALTE TEMPERATURE

Temperatura ambiente	45°C	50°C	55°C	60°C
Classe B	96%	93%	87%	83%
Classe F	100%	100%	100%	95%

DECLASSAMENTO PER ALTITUDINE

Altitudine	2000m	3000m	4000m
Classe B	94%	85%	75%
Classe F	100%	100%	95%

CODICI DI PROTEZIONE “IP” (International Protection)

I motori FELM, in condizioni standard, vengono costruiti con grado di protezione IP55 secondo la normativa in vigore.

PROTEZIONE CONTRO OGGETTI SOLIDI	
1° cifra	Descrizione
0	nessuna protezione
1	protezione da oggetti solidi di diametro maggiore di 50mm
2	protezione da oggetti solidi di diametro maggiore di 12mm
3	protezione da oggetti solidi di diametro maggiore di 2,5mm
4	protezione da oggetti solidi di diametro maggiore di 1mm
5	protezione da polveri: l'ingresso non ne è del tutto impedito, ma l'apparecchiatura è in grado di funzionare ancora
6	protezione totale da polveri

PROTEZIONE CONTRO I LIQUIDI	
2° cifra	Descrizione
0	nessuna protezione
1	protezione da gocce d'acqua provenienti dall'alto
2	protezione da gocce d'acqua deviate, rispetto alla verticale, al massimo di 15°
3	protezione da spruzzi d'acqua con inclinazione massima di 60°
4	protezione da spruzzi d'acqua provenienti da ogni direzione
5	protezione da getti d'acqua a bassa pressione provenienti da ogni direzione
6	protezione da onde marine o da forte getto d'acqua proveniente da qualsiasi direzione
7	protezione contro l'immersione per un periodo limitato e a precise condizioni di pressione
8	protezione contro l'immersione continua a precise condizioni di pressione



FORME COSTRUTTIVE E MONTAGGI BASE (IEC 60034-7)

Code I	Code II		Frame Size					Code I	Code II		Frame Size				
			63 ÷112	132	160 ÷250	280 ÷315	355÷400				63 ÷112	132	160 ÷250	280 ÷315	355÷400
IM B3	IM 1001	 1)	•	•	•	•	•	IM V1	IM 3011	 2)	•!	•	•	•	•
IM B35	IM 2001	 1) 2)	•	•	•	•	•	IM V15	IM 2011	 1) 2)	•!	•	•	•	•
IM B34	IM 2101	 1) 3)	•	•				IM V3	IM 3031	 2)	•	•	•	X	X
IM B5	IM 3001	 2)	•	•	•	X	X	IM V36	IM2031	 1) 2)	•	•	•	X	X
IM B6	IM 1051	 1)	•	•	•	X	X	IM V5	IM 1011	 1)	•!	•	•	X	X
IM B7	IM 1061	 1)	•	•	•	X	X	IM V6	IM 1031	 1)	•	•	•	X	X
IM B8	IM 1071	 1)	•	•	•	X	X	IM V18	IM 3611	 3)	•!	•			
IM B14	IM 3601	 3)	•	•				IM V19	IM 3631	 3)	•	•			

- | | |
|--|---|
| 1. Motors with feet | •: Available |
| 2. Flanged Motor: unthreaded through holes | X: Consult Felm |
| 3. Flanged Motor: threaded dead holes | !: Cast Iron Motors 63 frame without anti-rain canopy |

For other mountings refer to IEC 60034-7.



SCHEMI COLLEGAMENTO SECONDO IEC 34 - 08

Collegamenti stella e triangolo per motori ad una velocità:

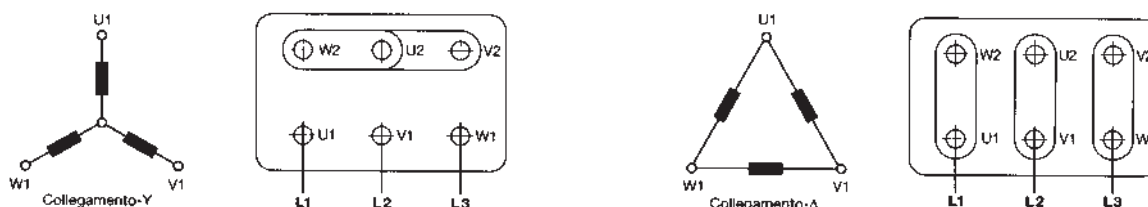

Numero di poli: 2, 4, 6, 8
 Velocità di sincronismo a 50 Hz: 3000, 1500, 1000, 750

Collegamento per motori a due velocità, due avvolgimenti separati:

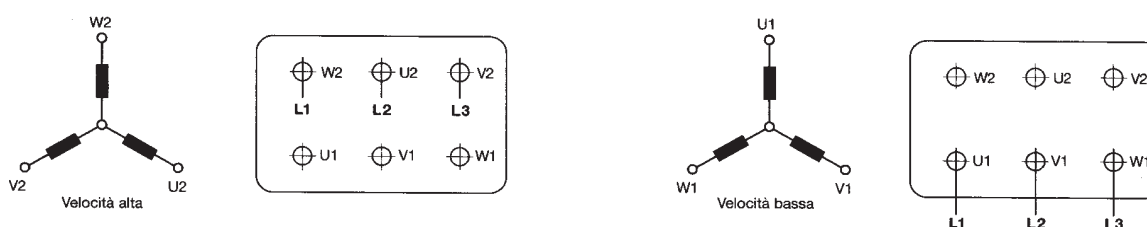

Numero di poli: 2/6, 2/8, 4/6, 6/8
 Velocità di sincronismo a 50 Hz: 3000/1000, 3000/750, 1500/1000, 1000/750.

Collegamento Dahlander per motori a due velocità, coppia costante:

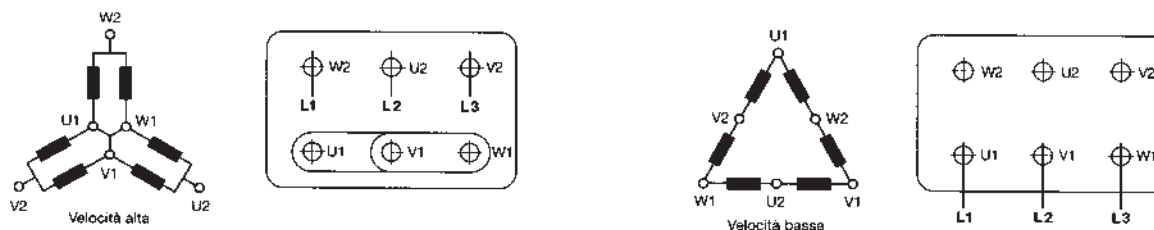

Numero di poli: 2/4, 4/8
 Velocità di sincronismo a 50 Hz: 3000/1500, 1500/750.

Collegamento Dahlander per motori a due velocità, coppia quadratica:

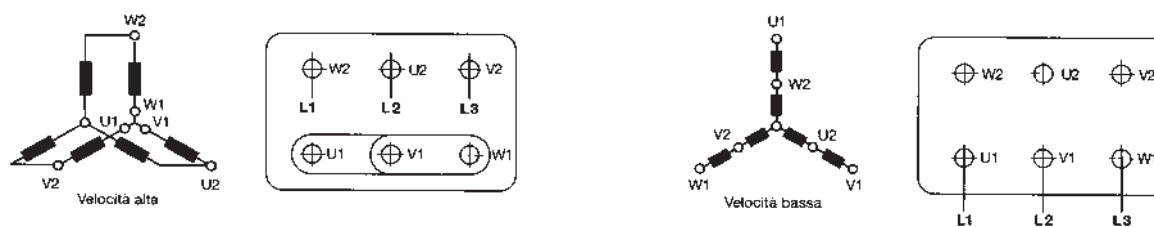

Numero di poli: 2/4, 4/8
 Velocità di sincronismo a 50 Hz: 3000/1500, 1500/750.

Collegamento motore monofase:

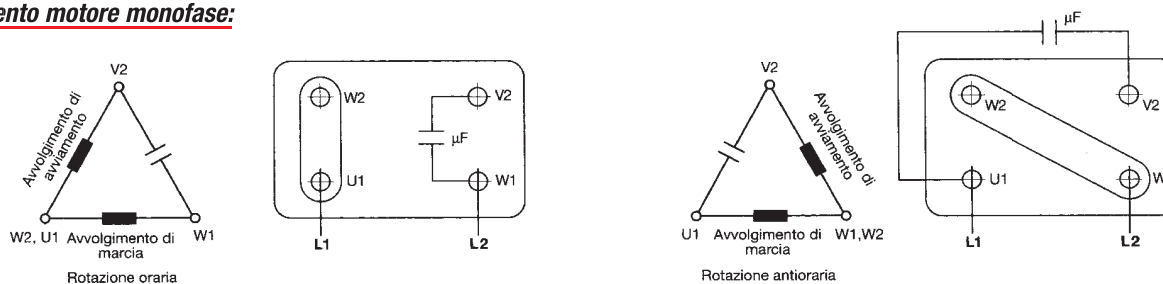

I motori monofase sono progettati per una sola tensione nominale. Hanno due avvolgimenti (marcia e avviamento) che devono essere collegati al condensatore fornito con il motore. Il senso di rotazione è reversibile.



Informazioni per ogni eventuale ordine

1. Il catalogo è indicativo Vi chiediamo di contattarci per ogni eventuale modifica, e/o richiesta.

2. In fase d'ordine specificare:

- grandezza
- potenza
- velocità
- voltaggio e frequenza
- forma costruttiva
- isolamento

3. Su richiesta Felm può fornire le seguenti opzioni:

- voltaggi speciali
- frequenze speciali
- isolamento classe H
- motori adatti per ambienti ostili
- doppia sporgenza d'albero
- motori con encoder
- esecuzione cavi uscenti
- verniciature speciali
- cuscinetti isolanti
- servoveilazioni
- scaldiglie anticondensa
- sonde PT 100 negli avvolgimenti
- sonde PT 100 nei cuscinetti
- Klixon

FELM has been operating in the electric motor sector since 1960 and has a well-consolidated background in the market of electrical machines. Thanks to the considerable experience of its staff, it can guarantee a technical back-up able to satisfy the most sophisticated technical requirements, both installations and maintenance, ensuring an International Service to its customers.

Our offices and warehouse cover an area of 10.000 square meters

Felm has a large stock, motors from KW 0, 12 up to 800 kW in different speed and thank to this and to the great distribution net can guarantee a good product availability and fast delivery in all Italy and Europe. Special attention is dedicated to the production process in the factory, from the careful selection of the materials, copper, insulation to the control of the impregnation and polymerisation processes (VPI Vacuum Pressure Impregnation).

The high levels of quality offered by FELM are proven by the ISO 9001 ICIM Certificate 2508/2:

Production of standard electric motors and special motors made in accordance to customer specifications. Commercialisation of electric motors and related electrical or electronic accessories for the construction and distribution of electric motors. Bearings are specially selected to guarantee best performance and product quality and a working life above the average.

Range of electric motors:

- Low Voltage standards IC 411, IC 611, IC 86W
- EFF 1 New international classes of motor performance- IE codes
new norm IEC 60034-30:2008 that defines the classes of performance
 - IE1 = standard performance (comparable to EFF2)
 - IE2 = high performance (comparable to EFF1)
 - IE3 = Premium Efficiency
- Medium voltage 3, 6, 11 kV. IC 411, IC 611, IC 86W
- Suitable for use with inverter (400 V, 690 V, 3 and 6 KV)
- Ring motors with wound rotor
- Explosion proof: Ex d, n
- NEMA, UL, CSA, EPACT
- GOST, Marine Classifying authority (RINA, Lloyd Register, DNV, ABS, BV, etc) nation and polymerisation processes (VPI Vacuum Pressure Impregnation).



ASYNCHRONOUS THREE PHASE ELECTRIC MOTORS - IP 55

GENERAL CHARACTERISTICS

Three phase asynchronous motors of cage rotor construction are in accordance with the following standards:

IEC (International Electrotechnical Commission) 60034-1.

Electrical: IEC/EN 60034-1, IEC/EN60034-2-1, IEC 60034-8, IEC 60034-12, IEC/EN 60034-9, IEC 60034-14, IEC 60034-30

Mechanical: IEC 60072, IEC/EN 60034-5, IEC/EN 600

Unel, The UNEL rules are in accordance to the IEC int. standard

The principal characteristics are as follows:

- Robust construction in aluminium alloy or alternative cast iron up to size 132 with demontable feet.
- Frame and endshields in cast iron for sizes 160 / 560 with fixed feet. Feet, on request be supply motors with yeknical box on side
- Modern design.
- Generous starting torques.
- High efficiency ie for maximum energy saving.
- 2,4,6 pole motors meet or exceed the highest efficiencyrequired by new IEC regulations:
IEC 60034-2-1 new rules concerning efficiency testing methods.
IEC 60034-30 new efficiency classes for motors
- Grade of Protection IP55 as standard
- Rated for continuous service - S1
- Low noise level.

The use of the best materials for the construction has allowed us to achieve motors with the optimum electrical and mechanical characteristics. The Felm standard range is ideal for arduous applications which require a high mechanical strength.

The motors are normally supplied for standard Eurovoltage supplies but on request can be produced for any non standard voltages and frequencies. In addition to Felm standard motors, the following derivatives can also be supplied:

- a - 2 or 3 speed motors with constant torque or fan/pump characteristics.
- b - forced ventilation for variable speed applications.
- c - motors with special tropicalisation treatment which are intended for use in humid tropical climates.
- d - flameproof EExd motors approved to ATEX standards.

INTERPRETATION OF MOTOR DATA (example)

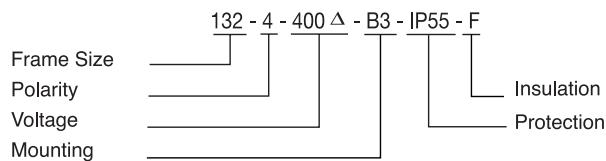

SERVICE CONDITIONS

Felm motors will operate satisfactorily in an ambient temperature range of -20°C to 40°C (class B temperature rise) and altitudes up to 1000 metres above sea level. On request it is possible to supply motors suitable for ambient temperatures and altitudes in excess of these standard conditions.

STANDARD POWER RANGE

2 pole - 0,18 ÷ 1000 KW

4 pole - 0,12 ÷ 1500 KW

6 pole - 0,06 ÷ 1500 KW

8 pole - 0,18 ÷ 1200 KW

VOLTAGE AND FREQUENCY

Standard Voltage 230 Δ / 400 Δ or 400 Δ / 690 Δ

Connection Δ for outputs up to 3 KW

Connection Δ for outputs 4 KW and above.

Frequency 50 Hz with possibility to use at 60 Hz

STATOR

The stator windings have a double impregnation treatment which solidifies to give good mechanical strength characteristics which is also highly resistant to humidity and thermal stress.

The class F insulation system with only class B temperature rise (80°C) provides an exceptional margin of safety and ensures a longer thermal life even in "abnormal" operating conditions

ROTOR

A die cast aluminium rotor is pressed or shrunk onto the shaft and dynamically balanced with half key in accordance with IEC 72.

FAN AND FANCOVER

The standard arrangement is IC411, Totally Enclosed Fan Ventilated. Cooling fans are located to the motor shaft with a key, and are designed for optimized cooling even at low speeds.

Fan covers are in sheet steel throughout the complete range.

BEARINGS

Felm motors are equipped with SKF bearings or primary brands.

Felm motors are provided with bearings adapted to the use requested, ball or roller bearings, grease lubricated.

Felm motors series FA2 (aluminium) and F2 (cast iron) frames 63 – 225 are equipped with sealed bearings (longlife), or roll bearings on request.

Felm motors serie F2 (cast iron) are equipped with ball bearings (or roll bearings on request) from frame 280 lubricated with lubricating nipples on the Drive End and on Not Drive End side.

For these bearings is necessary a periodically relubricated according to the "Installation, operation and maintenance manual" or the table on the motor.

TERMINAL BOX

For standard motors, the terminal box is mounted:

Frame 63 – 132 on the top of the motors, multi-mount for aluminium housing. Fram 160 – 450 on the top of the motors and on request on the side. The orientation shown is related looking the motor from shaft

The terminal box is equipped with cable gland and can be oriented to obtain the power input. From frame size 160 the motors are fitted with PTC, with a connection in the terminal box.

VIBRATION

Vibration of motors tested under no load conditions should not exceed the data in the following table:

Motors are balanced with half key in accordance to the IEC 60034-143

Frame size (mm)	63•132	160•225	250•355
Velocity (mm/sec)	1,8	2,8	4,5

Guaranteed values are upon request.

PROTECTION FOR TROPICAL/HOSTILE ENVIRONEMENTS

EXTERNAL SURFACES

On special request Felm can supply motors with particular treatments on the outside surface in order to resist better to humid and tropical ambient.

These motors will be painted with special paint-an enhanced form which ensures both internal and external surfaces from corrosive attack, on request we can offer inox screws.

WINDINGS

Felm motors have windings tropicalized as standard with antiflash paint.

THERMIC PROTECTION

Felm motors are equipped as standard with PTC in the winding from size 160.

On special request we can put PT100 in the windings klixon (normally closed) heaters, PT100 on the bearings

PAINTING

Felm motors are painted as standard with RAL BLUE 5010. On request it is possible to have special painting with an additional extra price.

DERATING FOR HIGH TEMPERATURE

Ambient temperature	45°C	50°C	55°C	60°C
Class B	96%	93%	87%	83%
Class F	100%	100%	100%	95%

DERATING FOR ALTITUDE

Altitude	2000m	3000m	4000m
Class B	94%	85%	75%
Class F	100%	100%	95%

DEGREES OF PROTECTION “IP” (International Protection)

FELM motors, in standard conditions, are with protection degree IP55 in according to the current regulations.

PROTECTION AGAINST SOLID BODIES

1 st digit	Description
0	no protect
1	protected against solid bodies of superior dimensions to 50mm
2	protected against solid bodies of superior dimensions to 12mm
3	protected against solid bodies of superior dimensions to 2,5mm
4	protected against solid bodies of superior dimensions to 1mm
5	protect against the powder
6	totally protect against the powder

PROTECTION AGAINST THE PENETRATION OF THE LIQUIDS

2 nd digit	Description
0	no protect
1	protect against the vertical fall of water drops
2	protect against the fall of water drops with inclination max of 15°
3	protect against the rain with maximum inclination 60°
4	protect against the water sprays coming from every direction
5	protect against water jets coming from every direction
6	protect against big waves coming from every direction
7	protect against the effects of immersion to precise conditions of pressure
8	protected against the effects of the submersion to precise conditions of pressure



FRAME AND TYPE OF MOUNTING (IEC 60034-7)

Code I	Code II		Frame Size					Code I	Code II		Frame Size				
			63 ÷112	132	160 ÷250	280 ÷315	355÷400				63 ÷112	132	160 ÷250	280 ÷315	355÷400
IM B3	IM 1001	1)	•	•	•	•	•	IM V1	IM 3011	2)	•!	•	•	•	•
IM B35	IM 2001	1) 2)	•	•	•	•	•	IM V15	IM 2011	1) 2)	•!	•	•	•	•
IM B34	IM 2101	1) 3)	•	•				IM V3	IM 3031	2)	•	•	•	X	X
IM B5	IM 3001	2)	•	•	•	X	X	IM V36	IM2031	1) 2)	•	•	•	X	X
IM B6	IM 1051	1)	•	•	•	X	X	IM V5	IM 1011	1)	•!	•	•	X	X
IM B7	IM 1061	1)	•	•	•	X	X	IM V6	IM 1031	1)	•	•	•	X	X
IM B8	IM 1071	1)	•	•	•	X	X	IM V18	IM 3611	3)	•!	•			
IM B14	IM 3601	3)	•	•				IM V19	IM 3631	3)	•	•			

- | | |
|--|---|
| 1. Motors with feet | •: Available |
| 2. Flanged Motor: unthreaded through holes | X: Consult Felm |
| 3. Flanged Motor: threaded dead holes | !: Cast Iron Motors 63 frame without anti-rain canopy |

For other mountings refer to IEC 60034-7.

CONNECTION DIAGRAMS ACCORDING TO IEC 34-08

Connection for single speed motors:

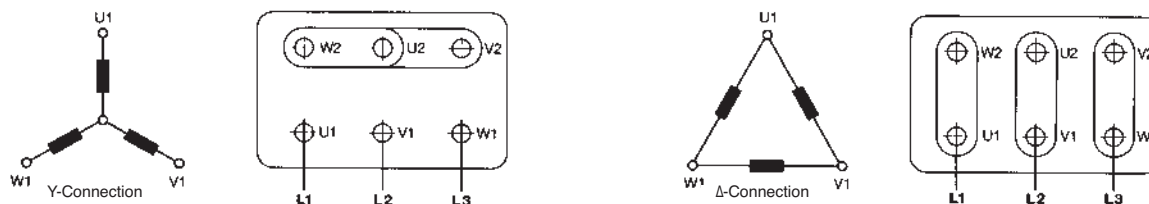

Number of pole: 2,4,6,8
Synchronous speed at 50 Hz: 3000, 1500, 1000, 750

Two separate windings for two speed motors:

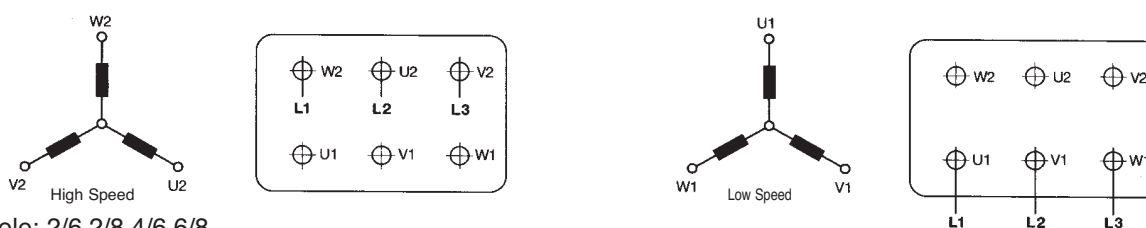

Number of pole: 2/6, 2/8, 4/6, 6/8
Synchronous speed at 50 Hz: 3000/1000, 3000/750, 1500/1000, 1000/750.

Dahlander system for two speed motors, constant torque:

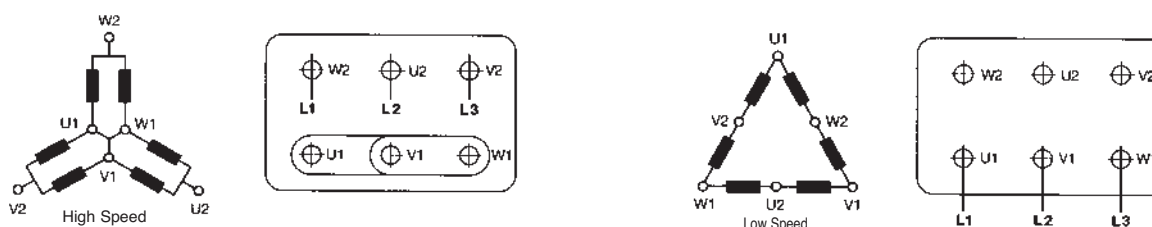

Number of pole: 2/4, 4/8
Synchronous speed at 50 Hz: 3000/1500, 1500/750.

Dahlander system for two speed motors, quadratic torque:

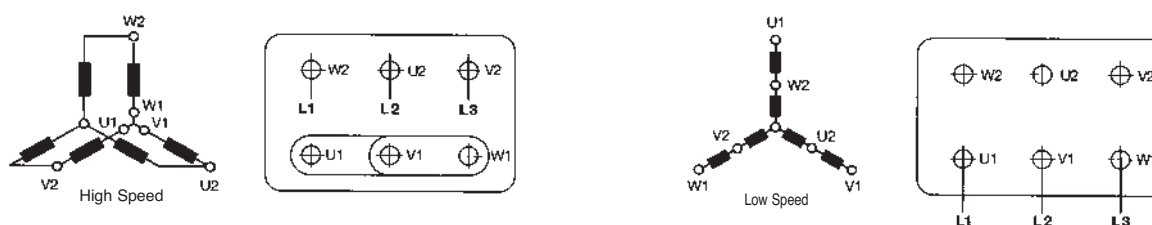

Number of pole: 2/4, 4/8
Synchronous speed at 50 Hz: 3000/1500, 1500/750.

Single phase motors connecting diagram:

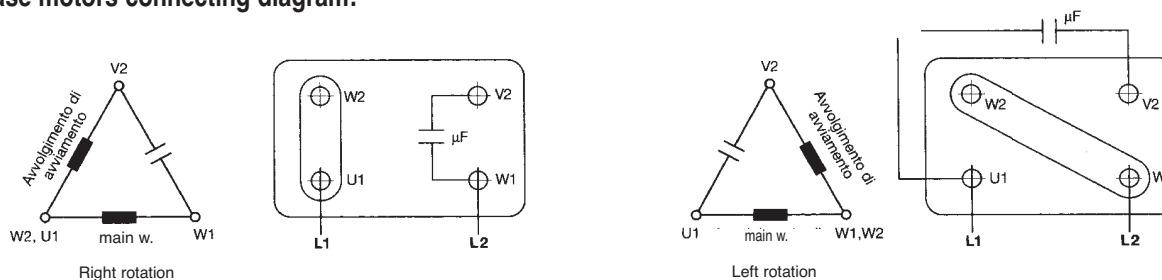

Single phase motors are designed for only one rated voltage. They have two windings (starting and main winding) which have to be connected to the capacitor supplied with the motor. The sense of rotation can be reversed according to the connecting diagram.



Information for ordering

1. The brochure is only for reference, it is supposed to change without notice in advance, please contact us when ordering.

2. Please specify:
 - greatness
 - power
 - speed
 - voltage and frequency
 - mounting structure
 - insulation class

3. Up on request Felm can supply the following options:
 - special voltage
 - special frequency
 - insulation class H
 - motors for aggressive ambient
 - double shaft
 - motors with encoder
 - loose lead
 - special painting
 - insulated bearing
 - forced ventilation
 - space heaters
 - PT 100 in the windings
 - PT 100 in the bearings
 - Klixon

SPECIFICHE TECNICHE SERIE IE2 MOTORE ALLUMINIO
 SERIES IE2 ALUMINIUM HOUSING
 TECHNICAL SPECIFICATION

Type	Output		Voltage (V)	Current (A)	Speed r/min	Eff. (%)			Power Factor	Tsn/Tn	Tmax/Tn	Weight
	KW	HP				50%	75%	100%				Kg
FA2 801-2	0,75	1	230/400	3.0/1.73	2800	76,5	77,3	77,4	0,813	2,2	2,3	9,5
FA2 802-2	1,1	1,5	230/400	4.2/2.43	2800	79,0	80,0	79,6	0,825	2,2	2,3	10,5
FA2 90S-2	1,5	2	230/400	5.53/3.19	2820	80,2	81,5	81,3	0,837	2,2	2,3	12,5
FA2 90L-2	2,2	3	230/400	7.93/4.58	2820	82,2	83,5	83,2	0,837	2,2	2,3	16
FA2 100L-2	3	4	230/400	10.5/6.06	2830	84,0	85,1	84,6	0,848	2,2	2,3	23
FA2 112M-2	4	5,5	400/690	7.97/4.6	2850	85,4	86,8	85,8	0,848	2,2	2,3	27,5
FA2 132S1-2	5,5	7,5	400/690	10.65/6.15	2870	86,7	87,3	87,0	0,860	2	2,3	39
FA2 132S2-2	7,5	10	400/690	14.35/8.28	2870	87,6	88,3	88,1	0,860	2	2,3	43
FA2 160M1-2	11	15	400/690	20.74/11.97	2900	89,0	89,8	89,4	0,860	2	2,3	77
FA2 160M2-2	15	20	400/690	27.99/16.16	2900	90,0	90,5	90,3	0,860	2	2,3	90
FA2 160L-2	18,5	25	400/690	33.83/19.53	2900	90,3	91,0	90,9	0,872	2	2,2	102
FA2 802-4	0,75	1	230/400	3.28/1.9	1380	77,3	79,8	79,6	0,720	2,3	2,3	10
FA2 90S-4	1,1	1,5	230/400	4.57/2.64	1400	79,9	81,7	81,4	0,743	2,3	2,3	12,5
FA2 90L-4	1,5	2	230/400	6.02/3.48	1400	82,1	83,5	82,8	0,755	2,3	2,3	15
FA2 100L1-4	2,2	3	230/400	8.42/4.86	1420	82,6	84,5	84,3	0,778	2,2	2,3	21,5
FA2 100L2-4	3	4	230/400	11.32/6.54	1420	84,2	85,7	85,5	0,778	2,2	2,3	25,5
FA2 112M-4	4	5,5	400/690	8.47/4.89	1430	85,8	87,0	86,6	0,790	2,2	2,3	32
FA2 132S-4	5,5	7,5	400/690	11.18/6.45	1450	87,4	88,3	87,7	0,813	2,2	2,3	42
FA2 132M-4	7,5	10	400/690	14.85/8.58	1450	88,2	89,0	88,7	0,825	2,2	2,3	51
FA2 160M-4	11	15	400/690	21.84/12.61	1460	89,1	90,0	89,8	0,813	2,2	2,3	80
FA2 160L-4	15	20	400/690	29.08/16.79	1460	90,2	91,1	90,6	0,825	2,2	2,3	100
FA2 90S-6	0,75	1	230/400	3.82/2.2	910	73,4	76,3	75,9	0,650	2	2,2	12,5
FA2 90L-6	1,1	1,5	230/400	5.25/3.03	910	77,0	78,8	78,1	0,673	2	2,2	16
FA2 100L-6	1,5	2	230/400	6.77/3.91	940	79,6	80,8	79,8	0,697	2	2,2	20
FA2 112M-6	2,2	3	230/400	9.69/5.59	940	80,4	81,6	81,8	0,697	2	2,2	26
FA2 132S-6	3	4	230/400	12.56/7.25	960	81,0	83,4	83,3	0,720	2	2,2	37
FA2 132M1-6	4	5,5	400/690	9.36/5.4	960	82,7	84,5	84,6	0,732	2	2,2	47
FA2 132M2-6	5,5	7,5	400/690	12.47/7.2	960	84,8	86,2	86,0	0,743	2	2,2	58
FA2 160M-6	7,5	10	400/690	16.78/9.69	970	86,4	87,5	87,2	0,743	2	2	77
FA2 160L-6	11	15		24.19/13.97	970	88,2	89,2	88,7	0,743	2	2	98

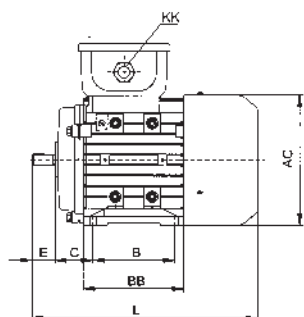

56-90

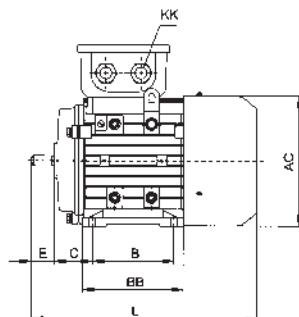

100-160

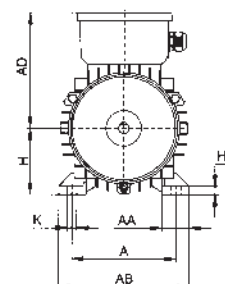

56-160

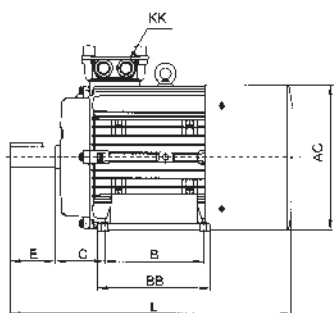

180-200

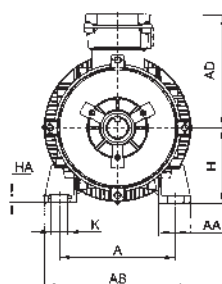

180-200

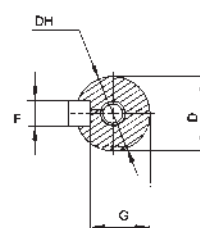

**DIMENSIONI B3
DIMENSION B3**

Type	A	AA	AB	BB	HA	AC	AD	B	C	D	DH	E	F	G	H	K	KK		Overall L
																	Metric	PG	
56	90	23	115	88	7	110	100	71	36	9	M4X12	20	3	7.2	56	5.8	1-M20X1.5	1-PG11	199
63	100	24	135	100	7	130	111	80	40	11	M4X12	23	4	8.5	63	7.0	1-M20X1.5	1-PG11	217
71	112	26	150	110	8	145	118	90	45	14	M5X12	30	5	11	71	7.0	1-M20X1.5	1-PG11	245
80	125	35	165	125	9	175	134	100	50	19	M6X16	40	6	15.5	80	10.0	1-M25X1.5	1-PG16	287
90S	140	37	180	125	10	195	140	100	56	24	M8X19	50	8	20.0	90	10.0	1-M25X1.5	1-PG16	315
90L	140	37	180	150	10	195	140	125	56	24	M8X19	50	8	20.0	90	10.0	1-M25X1.5	1-PG16	340
100L	160	40	205	172	11	215	160	140	63	28	M10X22	60	8	24.0	100	12.0	1-M32X1.5	1-PG21	385
112M	190	41	230	181	12	240	178	140	70	28	M10X22	60	8	24.0	112	12.0	2-M32X1.5	2-PG21	400
132S	216	51	270	186	15	275	206	140	89	38	M12X28	80	10	33.0	132	12.0	2-M32X1.5	2-PG21	483
132M	216	51	270	224	15	275	206	178	89	38	M12X28	80	10	33.0	132	12.0	2-M32X1.5	2-PG21	510
160M	254	55	320	260	18	330	255	210	108	42	M16X36	110	12	37.0	160	15.0	2-M40X1.5	2-PG29	615
160L	254	55	320	304	18	330	255	254	108	42	M16X36	110	12	37.0	160	16.0	2-M40X1.5	2-PG29	670
180M	279	75	350	315	18	355	272	241	221	48	M16X36	110	14	42.5	180	15	2-M32X1.5	2-PG29	765
180L	279	75	350	315	18	355	272	279	221	48	M16X36	110	14	42.5	180	15	2-M32X1.5	2-PG29	765
200L	318	100	398	355	24	355	272	305	133	55	M20X42	110	16	49	200	19	2-M32X1.5	2-PG36	790

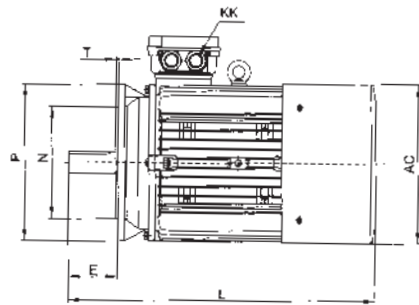

56-200

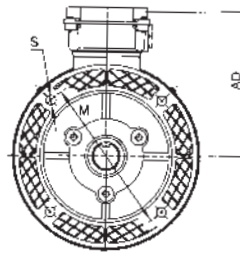

56-200

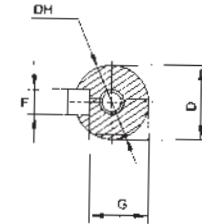

DIMENSIONI B5 DIMENSION B5

Type	HA	AC	AD	B	C	D	DH	E	F	G	H	K	KK		Overall dimensions						
													Metric	PG	L	M	N	P	S	T	
56	7	110	100	71	36	9	M4X12	20	3	7.2	56	5.8	1-M20X1.5	1-PG11	199	100	80	120	7	3.0	
63	7	130	111	80	40	11	M4X12	23	4	8.5	63	7.0	1-M20X1.5	1-PG11	217	115	95	140	10	3.0	
71	8	145	118	90	45	14	M5X12	30	5	11	71	7.0	1-M20X1.5	1-PG11	245	130	110	160	12	3.5	
80	9	175	134	100	50	19	M6X16	40	6	15.5	80	10.0	1-M25X1.5	1-PG16	287	165	130	200	12	3.5	
90S	10	195	140	100	56	24	M8X19	50	8	20.0	90	10.0	1-M25X1.5	1-PG16	315	165	130	200	12	3.5	
90L	10	195	140	125	56	24	M8X19	50	8	20.0	90	10.0	1-M25X1.5	1-PG16	340	165	130	200	12	3.5	
100L	11	215	160	140	63	28	M10X22	60	8	24.0	100	12.0	1-M32X1.5	1-PG21	385	215	180	250	15	4.0	
112M	12	240	178	140	70	28	M10X22	60	8	24.0	112	12.0	2-M32X1.5	2-PG21	400	215	180	250	15	4.0	
132S	15	275	206	140	89	38	M12X28	80	10	33.0	132	12.0	2-M32X1.5	2-PG21	483	265	230	300	15	4.0	
132M	15	275	206	178	89	38	M12X28	80	10	33.0	132	12.0	2-M32X1.5	2-PG21	510	265	230	300	15	4.0	
160M	18	330	255	210	108	42	M16X36	110	12	37.0	160	15.0	2-M40X1.5	2-PG29	615	300	250	350	19	5.0	
160L	18	330	255	254	108	42	M16X36	110	12	37.0	160	16.0	2-M40X1.5	2-PG29	670	300	250	350	19	5.0	
180M	18	355	272	241	121	48	M16X36	110	14	42.5	180	15.0	2-M32X1.5	2-PG29	765	300	250	350	19	5	
180L	18	355	272	279	121	48	M16X36	110	14	42.5	180	15.0	2-M32X1.5	2-PG29	765	300	250	350	19	5	
200L	24	355	272	305	133	55	M20X42	110	16	49	200	19	2-M32X1.5	2-PG36	790	350	300	400	19	5	

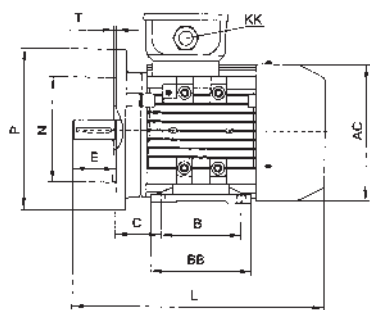

56-90

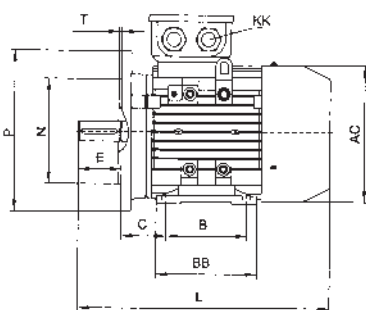

100-160

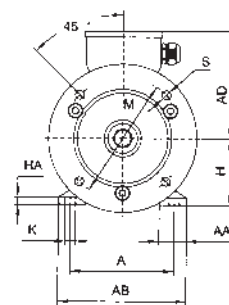

56-160

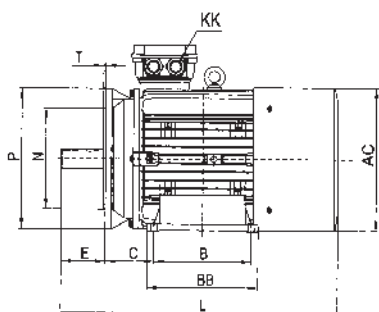

180-200

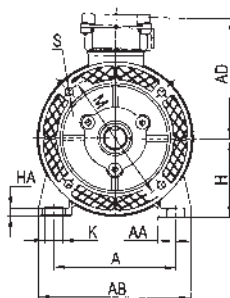

180-200

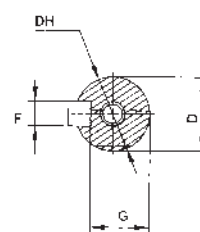

DIMENSIONI B35
DIMENSION B35

Type	A	AA	AB	BB	HA	AC	AD	B	C	D	DH	E	F	G	H	K	KK		Overall dimensions					
																	Metric	PG	L	M	N	P	S	T
56	90	23	115	88	7	110	100	71	36	9	M4X12	20	3	7.2	56	5.8	1-M20X1.5	1-PG11	199	100	80	120	7	3.0
63	100	24	235	100	7	130	111	80	40	11	M4X12	23	4	8.5	63	7.0	1-M20X1.5	1-PG11	217	115	95	140	10	3.0
71	112	26	150	110	8	145	118	90	45	14	M5X12	30	5	11	71	7.0	1-M20X1.5	1-PG11	245	130	110	160	12	3.5
80	125	35	165	125	9	175	134	100	50	19	M6X16	40	6	15.5	80	10.0	1-M25X1.5	1-PG16	287	165	130	200	12	3.5
90S	140	37	180	125	10	195	140	100	56	24	M8X19	50	8	20.0	90	10.0	1-M25X1.5	1-PG16	315	165	130	200	12	3.5
90L	147	37	180	150	10	195	140	125	56	24	M8X19	50	8	20.0	90	10.0	1-M25X1.5	1-PG16	340	165	130	200	12	3.5
100L	160	40	205	172	11	215	160	140	63	28	M10X22	60	8	24.0	100	12.0	1-M32X1.5	1-PG21	385	215	180	250	15	4.0
112M	190	41	230	181	12	240	178	140	70	28	M10X22	60	8	24.0	112	12.0	2-M32X1.5	2-PG21	400	215	180	250	15	4.0
132S	216	51	270	186	15	275	206	140	89	38	M12X28	80	10	33.0	132	12	2-M32X1.5	2-PG21	483	265	230	300	15	4.0
132M	216	51	270	224	15	275	206	178	89	38	M12X28	80	10	33.0	132	12.0	2-M32X1.5	2-PG21	510	265	230	300	15	4.0
160M	254	55	320	260	18	330	255	210	108	42	M16X36	110	12	37.0	160	15.0	2-M40X1.5	2-PG29	615	300	250	350	19	5.0
160L	254	55	320	304	18	330	255	254	108	42	M16X36	110	12	37.0	160	16.0	2-M40X1.5	2-PG29	670	300	250	350	19	5.0
180M	279	75	350	315	18	355	272	241	121	48	M16*36	110	14	42.5	180	15	2-M32X1.5	2-PG29	765	300	250	350	19	5
180L	279	75	350	315	18	355	272	279	121	48	M16*36	110	14	42.5	180	15	2-M32X1.5	2-PG29	765	300	250	350	19	5
200L	318	100	398	355	24	355	272	305	133	55	M20*42	110	16	49	200	19	2-M32X1.5	2-PG36	790	350	300	400	19	5

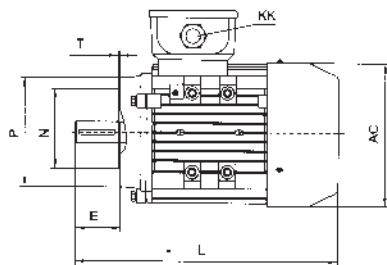
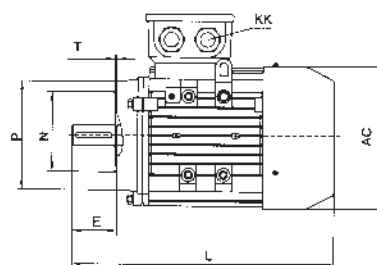
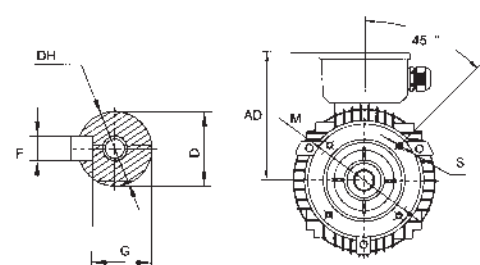
**56-90****100-160****56-160**

DIMENSIONI B14A DIMENSION B14A

Type	AC	AD	D	DH	E	F	G	KK		L	M	N	P	S	T
								Metric	PG						
56	110	100	9	M4X12	20	3	7.2	1-M20X1.5	1-PG11	199	65	50	80	M5	2.5
63	130	111	11	M4X12	23	4	8.5	1-M20X1.5	1-PG11	217	75	60	90	M5	2.5
71	145	114	18	M5X12	30	5	11.0	1-M20X1.5	1-PG11	245	85	70	105	M6	2.5
80	175	134	19	M6X16	40	6	15.5	1-M25X1.5	1-PG16	297	100	80	120	M6	3.0
90S	195	140	24	M8X19	50	8	20.0	1-M25X1.5	1-PG16	315	115	95	140	M8	3.0
90L	195	140	24	M8X19	50	8	20.0	1-M25X1.5	1-PG16	340	115	95	140	M8	3.0
100L	215	160	28	M10X22	60	8	24.0	1-M32X1.5	1-PG21	385	130	110	160	M8	3.5
112M	240	178	28	M10X22	60	88	24.0	2-M32X1.5	2-PG21	430	130	110	160	M8	3.5
132S	275	206	38	M12X28	80	10	33.0	2-M32X1.5	2-PG21	483	165	130	200	M10	3.5
132M	275	206	38	M12X28	80	10	33.0	2-M32X1.5	2-PG21	510	165	130	200	M10	3.5
160M	330	255	42	M16X36	110	12	37.0	2-M40X1.5	2-PG29	615	215	180	250	M12	4.0
160L	330	255	42	M16X36	110	12	37.0	2-M40X1.5	2-PG29	615	215	180	250	M12	4.0

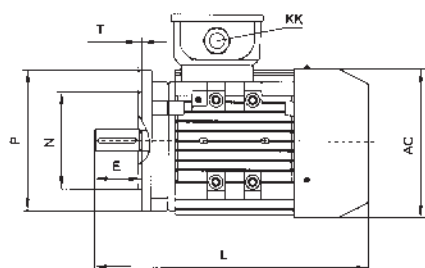

56-90

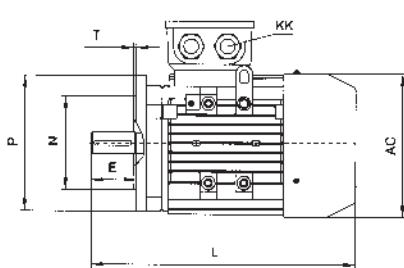

100-160

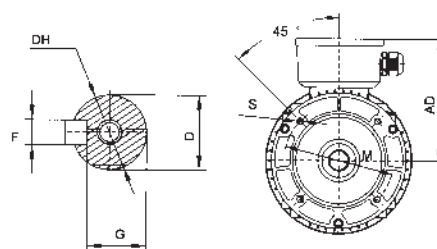

56-160

**DIMENSIONI B14B
DIMENSION B14B**

Type	AC	AD	D	DH	E	F	G	KK		L	M	N	P	S	T
								Metric	PG						
56	110	100	9	M4X12	20	3	7.2	1-M20X1.5	1-PG11	199	85	70	105	M6	2.5
63	130	111	11	M4X12	23	4	8.5	1-M20X1.5	1-PG11	217	100	80	120	M6	2.5
71	145	118	14	M5X12	30	5	11.0	1-M20X1.5	1-PG11	245	115	95	140	M8	3.0
80	175	134	19	M6X16	40	6	15.5	1-M25X1.5	1-PG16	297	130	110	160	M8	3.5
90S	195	140	24	M8X19	50	8	20.0	1-M25X1.5	1-PG16	315	130	110	160	M8	3.5
90L	195	140	25	M8X19	50	8	20.0	1-M25X1.5	1-PG16	340	130	110	160	M8	3.5
100L	215	160	28	M10X22	60	8	24.0	1-M32X1.5	1-PG21	385	165	130	200	M10	3.5
112M	240	178	28	M10X22	60	88	24.0	2-M32X1.5	2-PG21	400	165	130	200	M10	3.5
132S	275	206	38	M12X28	80	10	33.0	2-M32X1.5	2-PG21	483	215	180	250	M12	4.0
132M	274	206	38	M12X28	80	10	33.0	2-M32X1.5	2-PG21	510	215	180	250	M12	4.0
160M	330	255	42	M16X36	110	12	37.0	2-M40X1.5	2-PG29	615	265	230	300	M16	5.0
160L	330	255	42	M16X36	110	12	37.0	2-M40X1.5	2-PG29	670	265	230	300	M16	5.0

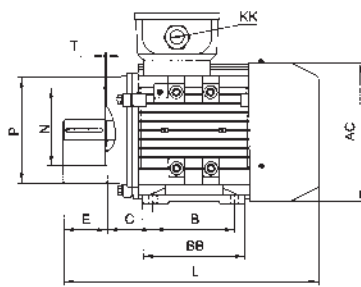
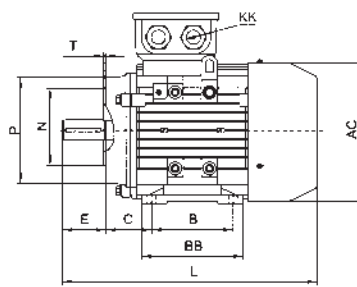
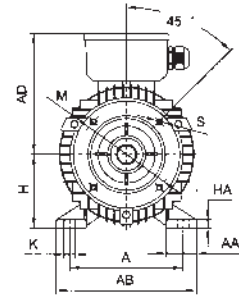
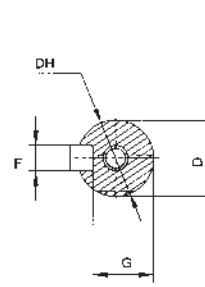
**56-90****90-160****56-160**

DIMENSIONI B34A DIMENSION B34A

Type	AC	AD	D	DH	E	F	G	KK		L	M	N	P	S	T
								Metric	PG						
56	110	100	9	M4X12	20	3	7.2	1-M20X1.5	1-PG11	199	65	50	80	M5	2.5
63	130	110	11	M4X12	23	4	8.5	1-M20X1.5	1-PG11	217	75	60	90	M5	2.5
71	145	118	14	M5X12	30	5	11.0	1-M20X1.5	1-PG11	245	85	70	105	M6	2.5
80	175	134	19	M6X16	40	6	15.5	1-M25X1.5	1-PG16	297	100	80	120	M6	3.0
90S	195	140	24	M8X19	50	8	20.0	1-M25X1.5	1-PG16	315	115	95	140	M8	3.0
90L	195	140	24	M8X19	50	8	20.0	1-M25X1.5	1-PG16	340	315	95	140	M8	3.0
100L	215	160	29	M10X22	60	8	24.0	1-M32X1.5	1-PG21	385	130	110	160	M8	3.5
112M	240	178	28	M10X22	60	88	24.0	2-M32X1.5	2-PG21	400	130	110	160	M8	3.5
132S	275	206	38	M12X28	80	10	33.0	2-M32X1.5	2-PG21	483	165	130	200	M10	3.5
132M	275	206	38	M12X28	80	10	33.0	2-M32X1.5	2-PG21	510	165	130	200	M10	3.5
160M	330	255	42	M16X36	110	12	37.0	2-M40X1.5	2-PG29	615	215	180	250	M12	4.0
160L	330	255	42	M16X36	110	12	37.0	2-M40X1.5	2-PG29	670	215	180	250	M12	4.0

CUSCINETTI BEARINGS

Frame size	Poles	Driving End	Non-driving End
80	2 TO 8	6204 2RS-C3 (6204 ZZ-C3)	6204 2RS-C3 (6204 ZZ-C3)
90	2 TO 8	6205 2RS-C3 (6205 ZZ-C3)	6205 2RS-C3 (6205 ZZ-C3)
100	2 TO 8	6206 2RS-C3 (6206 ZZ-C3)	6206 2RS-C3 (6206 ZZ-C3)
112	2 TO 8	6306 2RS-C3 (6206 ZZ-C3)	6206 2RS-C3 (6206 ZZ-C3)
132	2 TO 8	6308 2RS-C3 (6208 ZZ-C3)	6208 2RS-C3 (6208 ZZ-C3)
160	2 TO 8	6309 2RS-C3 (6309 ZZ-C3)	6309 2RS-C3 (6309 ZZ-C3)
180	2 TO 8	6311 ZZ-C3	6311 ZZ C3
200	2 TO 8	6312 ZZ-C3	6312 ZZ-C3

LISTA COMPONENTI – RICAMBI MOTORI IN ALLUMINO
LIST OF COMPONENTS - SPARE PARTS ALUMINIUM HOUSING

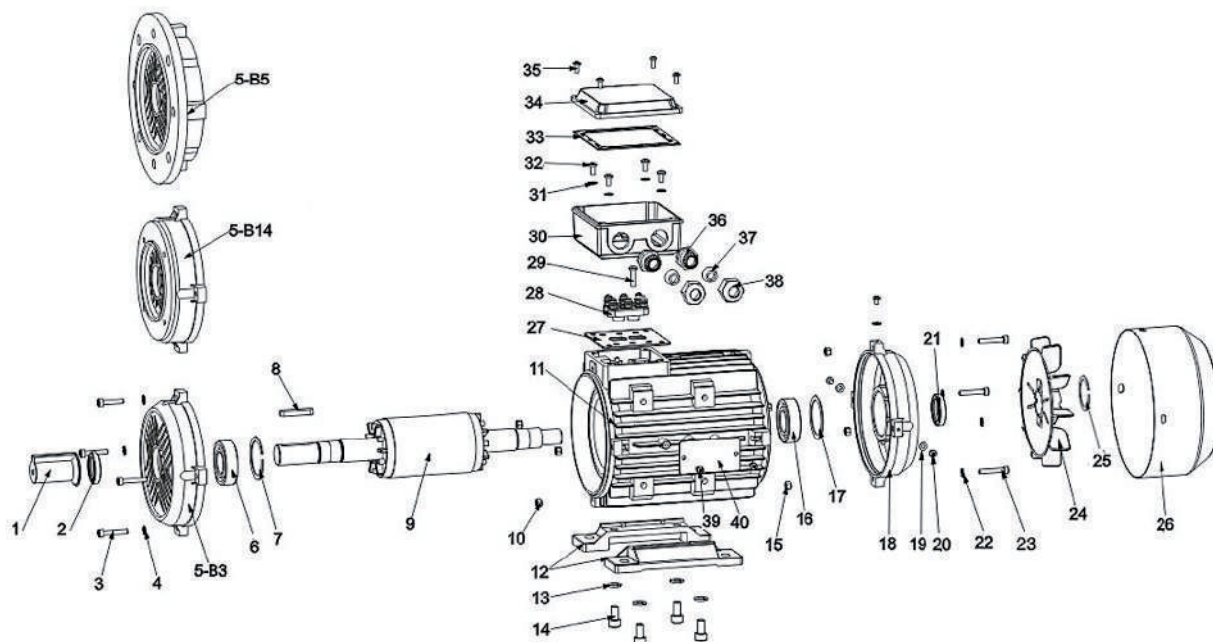

- | | | | |
|----|--|----|--|
| 1 | Protezione estremità albero – Shaft cover | 21 | Tenuta albero – Seal |
| 2 | Tenuta albero – Seal | 22 | Ranella - Washer |
| 3 | Viti fissaggio | 23 | Vite - Screw |
| 4 | Ranella - Washer | 24 | Ventola - Fan |
| 5 | Scudo lato DE – Shiel DE | 25 | Anello elastico (Sieger) - Ouch |
| 6 | Cuscinetto - Bearing | 26 | Calotta copri ventola – Fan cover |
| 7 | Anello elastico (Sieger) - Ouch | 27 | Guarnizione - Gasket |
| 8 | Chiavetta - Key | 28 | Basetta – Terminal block |
| 9 | Rotore - Rotor | 29 | Bullone - Bolt |
| 10 | Dado - Nut | 30 | Scatola morsetti – Terminal box |
| 11 | Carcassa con pacco statore –
Stator frame | 31 | Ranella - Washer |
| 12 | Piedi (B3) – Foot (B3) | 32 | Bullone - Bolt |
| 13 | Ranella anti allentamento – Spring gasket | 33 | Guarnizione per IP55 – Terminal seal IP55 |
| 14 | Vite - Screw | 34 | Coperchio scatola morsetti –
Terminal box cover |
| 15 | Dado - Nut | 35 | Bullone - Bolt |
| 16 | Cuscinetto - Bearing | 36 | Pressacavo – Cable glande |
| 17 | Anello di compensazione –
Compesation rng | 37 | Tenuta pressacavo – Cable glande seal |
| 18 | Scudo lato NDE – Shield NDE | 38 | Dado pressacavo – Cable glande-nut |
| 19 | Ranella - Washer | 39 | Rivetto - Rivet |
| 20 | Bullone - Bolt | 40 | Targa – Nameplate |

SPECIFICHE TECNICHE SERIE IE2 GHISA
SERIES IE2 CAST IRON HOUSING TECHNICAL SPECIFICATION

Type	Output		Voltage (V)	Current (A)	Speed r/min	Eff. (%)			Power Factor	Ia/In	Tst/Tn	Tmax/Tn	Rotor Inertia	Weight
	KW	HP				50%	75%	100%					kgm2	Kg.
F2 80K-2	0,75	1	230/400	2.9/1.7	2820	79,0	79,5	77,4	0,82	6,0	2,2	2,3	0,00085	17
F2 80G-2	1,1	1,5	230/400	4/2.3	2830	80,3	81,2	79,6	0,83	6,6	2,2	2,3	0,0011	18
F2 90S-2	1,5	2	230/400	5.5/3.17	2850	82,0	82,3	81,3	0,83	7,0	2,2	2,3	0,00146	23
F2 90L-2	2,2	3	230/400	7.8/4.5	2855	85,0	84,9	83,2	0,83	7,0	2,2	2,3	0,00185	26
F2 100L-2	3	4	230/400	10.2/5.88	2880	85,3	86,1	84,6	0,87	8,4	2,2	2,5	0,00325	34
F2 112M-2	4	5,5	400/690	7.65/4.4	2895	86,5	86,8	85,8	0,88	8,0	2,3	2,5	0,0055	41
F2 132S1-2	5,5	7,5	400/690	10.4/6	2910	88,0	88,4	87,5	0,88	7,5	2,2	2,5	0,01378	60
F2 132S2-2	7,5	10	400/690	14/8.1	2915	89,0	89,2	88,3	0,88	7,5	2,2	2,5	0,01456	63
F2 160M1-2	11	15	400/690	20.0/11.5	2935	89,5	90,0	89,4	0,89	7,0	2,20	2,5	0,0442	109
F2 160M2-2	15	20	400/690	26.9/15.5	2935	90,1	90,8	90,3	0,89	7,5	2,20	2,5	0,0549	119
F2 160L-2	18.5	25	400/690	32.5/18.8	2935	91,7	91,3	90,9	0,90	7,5	2,20	2,5	0,0654	136
F2 180M-2	22	30	400/690	39.1/22.6	2950	91,3	91,7	91,3	0,89	7,5	2	2,2	0,0955	172
F2 200L1-2	30	40	400/690	52.3/30.2	2955	92,2	92,7	92,0	0,90	8,5	2,00	2,30	0,153	223
F2 200L2-2	37	50	400/690	64.2/37.1	2955	92,4	92,8	92,5	0,90	8,5	2,00	2,30	0,173	242
F2 225M-2	45	60	400/690	77.7/44.9	2960	92,5	93,0	92,9	0,90	7,5	2,00	2,30	0,268	302
F2 250M-2	55	75	400/690	94.6/54.6	2970	92,4	93,2	93,2	0,90	7,5	2,00	2,30	0,365	382
F2 280S-2	75	100	400/690	128.2/74	2975	92,3	93,5	93,8	0,90	7,2	2,00	2,30	0,601	515
F2 280M-2	90	125	400/690	154.4/89.1	2975	92,9	94,0	94,1	0,90	7,2	2,00	2,30	0,683	545
F2 315S-2	110	150	400/690	185/106.8	2980	92,8	94,7	94,3	0,91	7,1	1,80	2,20	1,408	930
F2 315M-2	132	180	400/690	223.8/129.2	2980	93,6	94,6	94,6	0,90	7,1	1,80	2,20	1,558	980
F2 315L1-2	160	220	400/690	270.7/156.3	2980	94,5	95,5	94,8	0,90	7,1	1,80	2,20	1,726	1090
F2 315L2-2	200	270	400/690	337.7/195	2980	94,0	94,8	95,0	0,90	7,1	1,80	2,20	1,941	1190
F2 355M-2	250	340	400/690	422/243.6	2980	94,7	95,3	95,0	0,90	7,1	1,60	2,20	3,296	1710
F2 355L1-2	280	380	400/690	467.5/269.9	2980	94,5	95,2	95,0	0,91	7,1	1,60	2,20	3,849	1870
F2 355L2-2	315	430	400/690	526/303.7	2980	94,6	95,4	95,0	0,91	7,1	1,60	2,20	3,95	1920
F2 355LY-2	355	480	400/690	605.4/349.5	2975	94,7	95,5	95,1	0,89	7,1	1,70	2,40	4,051	1975
F2 355X-2	375	510	400/690	640/369.5	2980	94,6	95,1	95,1	0,89	7,5	1,10	2,40	4,8	2180
F2 400M1-2	355	480	400/690	599/345.8	2985	94,4	94,9	95,0	0,90	7,5	1,60	2,00	7,45	2880
F2 400M1-2	375	510	400/690	605/349.3	2985	94,6	95,0	95,1	0,89	7,5	1,60	2,00	7,45	2930

SPECIFICHE TECNICHE SERIE IE2 GHISA
SERIES IE2 CAST IRON HOUSING TECHNICAL SPECIFICATION

Type	Output		Voltage (V)	Current (A)	Speed r/min	Eff. (%)			Power Factor	Ia/In	Tst/Tn	Tmax/Tn	Rotor Inertia	Weight Kg.
	KW	HP				50%	75%	100%						
F2 80G-4	0,75	1	230/400	3,35/1,94	1415	0,8	80.1	79.6	0,70	6,0	2,30	2,30	0,00148	19
F2 90S-4	1,1	1,5	230/400	4,8/2,8	1415	79.8	81.6	81.4	0,70	6,5	3,10	3,40	0,00212	23
F2 90L-4	1,5	2	230/400	6,2/3,6	1425	82,5	83,2	82,8	0,73	6,5	3,20	3,40	0,00287	29
F2 100L1-4	2,2	3	230/400	8,3/4,8	1435	84,0	84,7	84,3	0,79	7,0	3,00	3,50	0,00606	35
F2 100L2-4	3	4	230/400	11,5/6,7	1450	85,1	85,9	85,5	0,76	7,0	2,80	3,40	0,00779	39
F2 112M-4	4	5,5	230/400	15,0/8,7	1450	86,2	86,9	86,6	0,77	7,0	2,50	3,50	0,01176	45
F2 132S-4	5,5	7,5	400/690	11,0/6,3	1450	87,9	88,6	87,7	0,82	7,0	2,40	3,30	0,02465	62
F2 132M-4	7.5	10	400/690	14,9/8,6	1455	88,4	88,9	88,7	0,82	7,0	2,50	3,80	0,03301	74
F2 160M-4	11	15	400/690	21,3/12,3	1460	90,5	91,0	89,8	0,83	7,0	2,10	2,80	0,0808	115
F2 160L-4	15	20	400/690	28.1/16,2	1460	90,8	91,3	90,6	0,85	7,0	2,30	3,70	0,1052	135
F2 180M-4	18,5	25	400/690	34,5/19,9	1470	90,7	91,5	91,2	0,85	7,5	2,2	3,5	0,1499	170
F2 180 L-4	22	30	400/690	40,3/23,2	1470	91,1	91,9	91,6	0,86	7,5	2,1	3,3	0,1659	184
F2 200L-4	30	40	400/690	54.6/31,5	1470	91,7	92,8	92,3	0,86	7,0	1,90	2,80	0,273	235
F2 225S-4	37	50	400/690	67,0/38,7	1480	92,2	93,0	92,7	0,86	7,5	1,70	2,90	0,469	290
F2 225M-4	45	60	400/690	81,1/46,8	1480	93,1	93,9	93,1	0,86	7,5	2,00	3,00	0,538	326
F2 250M-4	55	75	400/690	97,6/56,4	1480	92,8	93,7	93,5	0,87	7,2	2,20	3,30	0,689	385
F2 280S-4	75	100	400/690	130.9/75,6	1485	93,8	94,2	94,0	0,88	6,4	2,10	3,40	1,267	515
F2 280M-4	90	125	400/690	155,0/89,5	1485	93,9	94,3	94,2	0,89	7,1	2,10	3,40	1,552	605
F2 315S-4	110	150	400/690	191,0/110,4	1485	93,9	94,7	94,5	0,88	6,9	2,10	2,20	2,98	931
F2 315M-4	132	180	400/690	229,0/132,2	1485	94,2	95,0	94,7	0,88	6,9	2,10	2,22	3,48	1017
F2 315L1-4	160	220	400/690	277,0/160,0	1485	94,8	95,4	94,9	0,88	6,9	2,10	2,20	3,678	1085
F2 315L2-4	200	270	400/690	341,1/197,1	1485	95,0	95,7	95,1	0,89	6,9	2,10	2,20	4,47	1200
F2 355 M-4	250	340	400/690	422,0/243,9	1490	94,9	95,6	95,1	0,90	6,9	2,10	2,20	7,164	1740
F2 355 L1-4	280	380	400/690	478,0/276,3	1490	94,8	95,5	95,1	0,89	6,9	2,10	2,20	7,903	1830
F2 355 L-4	315	430	400/690	531,0/307,0	1490	94,9	95,4	95,1	0,90	6,9	2,10	2,20	8,702	1975
F2 355 L3-4	355	480	400/690	606,0/350,2	1490	94,6	95,0	95,1	0,89	6,9	2,10	2,20	9,645	2148
F2 355 LX-4	375	510	400/690	639,0/369,3	1490	95,0	95,2	95,1	0,89	6,9	2,10	2,20	10,621	2266
F2 400M1-4	355	480	400/690	606,0/350,2	1490	94,6	95,0	95,1	0,89	6,9	1,60	2,00	14,72	2930
F2 400M2-4	375	510	400/690	639,0/369,3	1490	95,0	95,2	95,1	0,89	6,9	1,60	2,00	14,95	2980

SPECIFICHE TECNICHE SERIE IE2 GHISA
SERIES IE2 CAST IRON HOUSING TECHNICAL SPECIFICATION

Type	Output		Voltage (V)	Current (A)	Speed r/min	Eff. (%)			Power Factor	Ia/In	Tst/Tn	Tmax/Tn	Rotor Inertia	Weight
	KW	HP				50%	75%	100%					kgm2	Kg.
F2 90S-6	0,75	1	230/400	3,6/2,1	925	75,6	76,2	75,9	0,68	5,5	2,00	2,30	0,00297	24
F2 90L-6	1,1	1,5	230/400	5,2/3,0	930	77,8	78,6	78,1	0,68	5,5	2,00	2,30	0,00287	26
F2 100L-6	1,5	2	230/400	6,5/3,8	955	79,5	80,5	79,8	0,72	5,5	2,00	2,20	0,00745	34
F2 112M-6	2,2	3	230/400	9,3/5,4	945	81,8	82,8	81,8	0,72	6,5	2,00	2,20	0,01324	40
F2 132S-6	3	4	230/400	11,5/6,8	960	83,6	84,1	83,3	0,77	6,3	2,10	2,50	0,02821	57
F2 132M1-6	4	5,5	400/690	8,9/5,1	960	84,4	85,2	84,6	0,77	6,5	2,10	2,50	0,03716	73
F2 132M2-6	5,5	7,5	400/690	11,8/6,8	960	85,8	86,5	86,0	0,78	6,5	2,10	2,50	0,04889	77
F2 160M-6	7.5	10	400/690	16,6/9,6	965	87,2	88,0	87,2	0,75	6,5	2,00	2,30	0,0877	110
F2 160L-6	11	15	400/690	23,2/13,4	965	89,1	89,7	88,7	0,77	6,5	2,00	2,30	0,1212	133
F2 180 L-6	15	20	400/690	29,8/17,2	970	89,2	90,5	89,7	0,81	7,5	2,00	2,30	0,2086	174
F2 200L1-6	18,5	25	400/690	36,5/21,0	975	89,4	90,9	90,4	0,81	7,0	2,10	2,40	0,302	219
F2 200L2-6	22	30	400/690	42,6/24,6	975	90,3	91,5	90,9	0,82	7,0	2,10	2,40	0,342	228
F2 225M-6	30	40	400/690	57,6/33,2	985	91,3	92,6	91,7	0,82	7,5	2,00	2,30	0,576	296
F2 250M-6	37	50	400/690	67,4/38,9	985	92,0	92,5	92,2	0,86	7,0	2,10	2,50	0,807	380
F2 280S-6	45	60	400/690	82,4/47,6	990	91,2	92,8	92,7	0,85	7,0	2,10	2,50	1,474	470
F2 280M-6	55	75	400/690	100,3/57,9	990	92,3	93,3	93,1	0,85	7,0	2,10	2,50	1,732	545
F2 315S-6	75	100	400/690	134,3/77,6	985	93,2	93,9	93,7	0,86	7,0	2,00	2,20	3,194	866
F2 315M-6	90	125	400/690	163,0/94,2	985	93,1	93,9	94,0	0,85	6,7	2,00	2,20	3,723	948
F2 315L1-6	110	150	400/690	194,0/112,1	985	93,9	94,3	94,3	0,87	6,7	2,00	2,20	4,526	1120
F2 315L2-6	132	180	400/690	234,0/135,2	985	94,2	94,9	94,6	0,86	6,7	2,00	2,20	5,157	1185
F2 355 M 1-6	160	220	400/690	280,0/161,8	990	94,5	95,0	94,8	0,87	7,6	1,90	2,00	9,27	1705
F2 355 M 2-6	200	270	400/690	349,0/201,7	990	94,1	94,5	95,0	0,87	7,6	1,90	2,00	10,8	1890
F2 355L 6	250	340	400/690	432,0/249,7	990	95,1	95,2	95,0	0,88	7,5	1,90	2,00	11,8	2000
F2 355L3B-6	280	380	400/690	489,0/282,6	990	95,0	95,3	95,0	0,87	7,5	1,90	2,00	12,9	2080
F2 400M1-6	315	430	400/690	551,0/318,4	990	93,0	94,4	95,0	0,87	6,8	1,40	2,00	21,2	3440
F2 400M2-6	355	480	400/690	621,0/358,9	990	94,2	94,8	95,0	0,87	6,8	1,40	2,00	23,5	3680
F2 400M3-6	375	510	400/690	655,0/378,6	990	94,2	94,9	95,0	0,87	7,0	1,40	2,00	24,8	3750

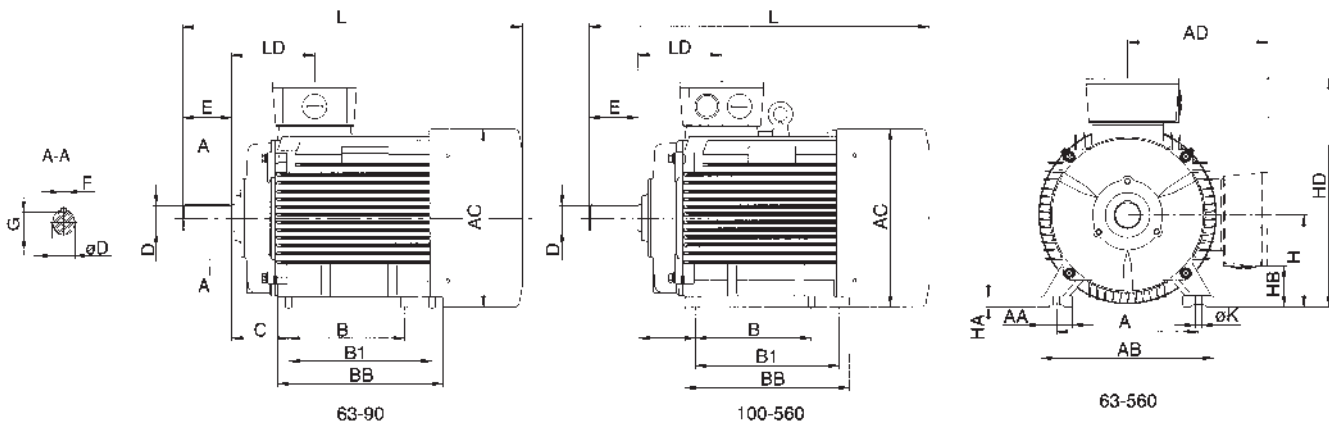

◆ B3

frame	Pole	Dimension							Dimension											
		A	B	B1	C	CA	H	K	AA	AB	AC	AD	BB	HA	HB	HB		LD	L	LC
		On top		L&R																
63	2-8	100	80	-	40	-	63° -0,5	7	30	135	130	-	115	8	-	180	-	65	225	253
71	2-8	112	90	-	45	-	71° -0,5	7	32	150	145	-	125	8	-	195	-	70	250	285
80	2-8	125	100	-	50	98	80° -0,5	10	35	160	160	145	130	12	36	225	160	75	280	336
90S	2-8	140	100	-	56	117	90° -0,5	10	36	180	180	155	140	12	50	245	180	75	315	373
90L	2-8	140	125	-	56	117	90° -0,5	10	36	180	180	155	165	12	50	245	180	75	340	373
100L	2-8	160	140	-	63	120	100° -0,5	12	40	200	200	180	175	14	55	280	200	83	375	443
112M	2-8	190	140	-	70	138	112° -0,5	12	45	230	220	190	180	15	60	305	222	87	400	468
132S	2-8	216	140	-	89	164	132° -0,5	12	55	265	260	220	190	18	65	355	262	102	465	553
132M	2-8	216	178	-	89	146	132° -0,5	12	55	265	260	220	230	18	65	355	262	102	505	593
160M	2-8	254	210	-	108	188	160° -0,5	15	65	315	315	265	260	20	81	425	385	146	608	726
160L	2-8	254	254	-	108	188	160° -0,5	15	65	315	315	265	305	20	81	425	385	146	652	770
180M	2.4	279	241	-	121	226	180° -0,5	15	70	350	360	280	315	22	105	460	420	161	690	808
180L	4-8	279	279	-	121	228	180° -0,5	15	70	350	360	280	350	22	105	460	420	161	730	848
200L	2-8	318	305	-	133	220	200° -0,5	19	70	390	400	310	370	25	85	510	475	186	760	878
225S	4-8	356	286	-	149	243	225° -0,5	19	75	435	450	335	370	28	110	555	535	189	810	928
225M	2	356	311	-	149	243	225° -0,5	19	75	435	450	335	395	28	110	555	535	189	805	923
	4-8	356	311	-	149	198	225° -0,5	19	75	435	450	335	395	28	110	555	535	189	835	953
250M	2	406	349	-	168	261	250° -0,5	24	80	485	485	375	445	30	110	625	570	207	910	1028
	4-8	406	349	-	168	261	250° -0,5	24	80	485	485	375	445	30	120	625	570	207	910	1028
280S	2	457	368	-	190	295	280° -1,0	24	85	545	550	405	490	35	142	685	660	215	985	1103
	4-8	457	368	-	190	315	280° -1,0	24	85	545	550	405	490	35	142	685	660	215	1005	1153
280M	2	457	419	-	190	289	280° -1,0	24	85	545	550	405	540	35	142	685	660	215	1030	1148
	4-8	457	419	-	190	319	280° -1,0	24	85	545	550	405	540	35	142	685	660	215	1060	1208
315S	2	508	406	-	216	426	315° -1,0	28	120	630	625	560	570	45	110	875	780	257	1180	1328
	4-8	508	406	-	216	426	315° -1,0	28	120	630	625	560	570	45	110	875	780	257	1210	1358
315M 315L	2	508	457	508	216	485	315° -1,0	28	120	630	625	560	680	45	110	875	780	257	1290	1438
	4-8	508	457	508	216	485	315° -1,0	28	120	630	625	560	680	45	110	875	780	257	1320	1498
355M	2	610	500	560	254	640	355° -1,0	28	120	730	700	615	750	52	110	970	830	284	1526	1674
	4-8	610	500	560	254	640	355° -1,0	28	120	730	700	615	750	52	110	970	830	284	1556	1734
355L	2	610	560	630	254	580	355° -1,0	28	120	730	700	615	750	52	110	970	830	284	1526	1674
	4-8	610	560	630	254	580	355° -1,0	28	120	730	700	615	750	52	110	970	830	284	1556	1734
400M 400L	2	686	710	-	280	698	400° -1,0	35	120	810	860	-	1100	45	-	1090	-	362	1850	2028
	4-8	686	710	-	280	733	400° -1,0	35	120	810	860	-	1100	45	-	1090	-	362	1925	2143

Dimensioni secondo albero (NDE) su altra tabella (pag. 48)
The second shaft dimension (NDE) will be showed in another table (pag. 48)

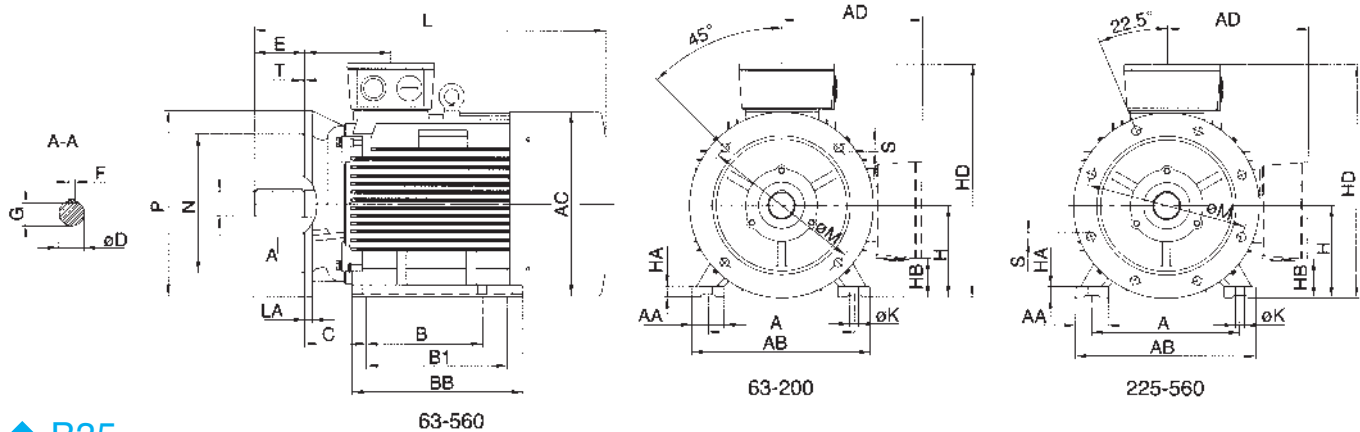

◆ B35

Frame	Poles	Dimension													Dimension												
		A	B	B1	C	CA	H	K	M	N	P	R	S	T	AA	AB	AC	AD	BB	HA	HB	HD		LA	LD	L	LC
		Top		L&R		LA		LD		L		LC															
80	2-8	125	100	-	50	98	80° -0.5	10	165	130	200	0	4-Ø12	4	35	160	160	145	130	12	36	225	160	12	75	280	336
90S	2-8	140	100	-	56	117	90° -0.5	10	165	130	200	0	4-Ø12	4	36	180	180	155	140	12	50	245	180	12	75	315	373
90L	2-8	140	125	-	56	117	90° -0.5	10	165	130	200	0	4-Ø12	4	36	180	180	155	165	12	50	245	180	12	75	340	373
100L	2-8	160	140	-	63	120	100° -0.5	12	215	180	250	0	4-Ø15	4	40	200	200	180	175	14	55	280	200	13	83	375	443
112M	2-8	190	140	-	70	138	112° -0.5	12	215	180	250	0	4-Ø15	4	45	230	220	190	180	15	60	305	222	14	87	400	468
132S	2-8	216	140	-	89	164	132° -0.5	12	265	230	300	0	4-Ø15	4	55	265	260	220	190	18	65	355	262	14	102	465	553
132M	2-8	216	178	-	89	146	132° -0.5	12	265	230	300	0	4-Ø15	4	55	265	260	220	230	18	65	355	262	14	102	505	593
160M	2-8	254	210	-	108	188	160° -0.5	15	300	250	350	0	4-Ø19	5	65	315	315	265	260	20	81	425	385	15	146	608	726
160L	2-8	254	254	-	108	188	160° -0.5	15	300	250	350	0	4-Ø19	5	65	315	315	265	305	20	81	425	385	15	146	652	770
180M	2.4	279	241	-	121	226	180° -0.5	15	300	250	350	0	4-Ø19	5	70	350	360	280	315	22	105	460	420	15	161	690	808
180L	4-8	279	279	-	121	228	180° -0.5	15	300	250	350	0	4-Ø19	5	70	350	360	280	350	22	105	460	420	15	161	730	848
200L	2-8	318	305	-	133	220	200° -0.5	19	350	300	400	0	4-Ø19	5	70	390	400	310	370	25	85	510	475	17	186	760	878
225S	4-8	356	286	-	149	243	225° -0.5	19	400	350	450	0	4-Ø19	5	75	435	450	335	370	28	110	555	535	20	189	810	928
225M	2	356	311	-	149	243	225° -0.5	19	400	350	450	0	8-Ø19	5	75	435	450	335	395	28	110	555	535	20	189	805	923
	4-8	356	311	-	149	198	225° -0.5	19	400	350	450	0	8-Ø19	5	75	435	450	335	395	28	110	555	535	20	189	835	953
250M	2	406	349	-	168	261	250° -0.5	24	500	450	550	0	8-Ø19	5	80	485	485	375	445	30	110	625	570	22	207	910	1028
	4-8	406	349	-	168	261	250° -0.5	24	500	450	550	0	8-Ø19	5	80	485	485	375	445	30	120	625	570	22	207	910	1028
280S	2	457	368	-	190	295	280° -1.0	24	500	450	550	0	8-Ø19	5	85	545	550	405	490	35	142	685	660	22	215	985	1103
	4-8	457	368	-	190	315	280° -1.0	24	500	450	550	0	8-Ø19	5	85	545	550	405	490	35	142	685	660	22	215	1005	1153
280M	2	457	419	-	190	289	280° -1.0	24	500	450	550	0	8-Ø19	5	85	545	550	405	540	35	142	685	660	22	215	1030	1148
	4-8	457	419	-	190	319	280° -1.0	24	500	450	550	0	8-Ø19	5	85	545	550	405	540	35	142	685	660	22	215	1060	1208
315S	2	508	406	-	216	426	315° -1.0	28	600	550	660	0	8-Ø24	6	120	630	625	560	570	45	110	875	780	22	257	1180	1328
	4-8	508	406	-	216	426	315° -1.0	28	600	550	660	0	8-Ø24	6	120	630	625	560	570	45	110	875	780	22	257	1210	1358
315M	2	508	457	508	216	485	315° -1.0	28	600	550	660	0	8-Ø24	6	120	630	625	560	680	45	110	875	780	22	257	1290	1438
	315L	4-8	508	457	508	216	485	315° -1.0	28	600	550	660	0	8-Ø24	6	120	630	625	560	680	45	110	875	780	22	257	1320
355M	2	610	500	560	254	640	355° -1.0	28	740	680	800	0	8-Ø24	6	120	730	700	615	750	52	125	970	830	25	284	1526	1674
	4-8	610	500	560	254	640	355° -1.0	28	740	680	800	0	8-Ø24	6	120	730	700	615	750	52	125	970	830	25	284	1556	1734
355L	2	610	560	630	254	580	355° -1.0	28	740	680	800	0	8-Ø24	6	120	730	700	615	750	52	125	970	830	25	284	1526	1674
	4-8	610	560	630	254	580	355° -1.0	28	740	680	800	0	8-Ø24	6	120	730	700	615	750	52	125	970	830	25	284	1556	1734
400M	2	686	710	-	280	698	400° -1.0	35	940	880	1000	0	8-Ø28	6	120	810	860	-	1100	45	-	1090	-	25	362	1850	2028
	400L	4-8	686	710	-	280	733	400° -1.0	35	940	880	1000	0	8-Ø28	6	120	810	860	-	1100	45	-	1090	-	25	362	1925

R= distance from flange to shaft shoulder.

Dimensioni secondo albero (NDE) su altra tabella (pag. 48)
The second shaft dimension (NDE) will be showed in another table (pag. 48)

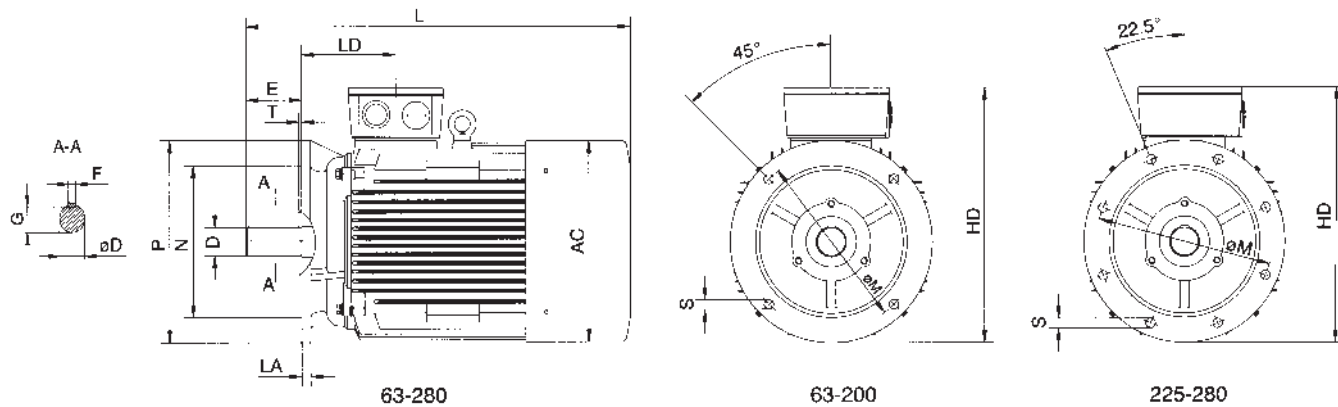

◆ B5

Frame	Pole	Dimension						Dimension					
		M	N	P	R	S	T	AC	AD	LA	LD	L	LC
80	2-8	165	130	200	0	4-ø12	4	160	145	12	75	280	336
90S	2-8	165	130	200	0	4-ø12	4	180	155	12	75	315	373
90L	2-8	165	130	200	0	4-ø12	4	180	155	12	75	340	373
100L	2-8	215	180	250	0	4-ø15	4	200	180	13	83	375	443
112M	2-8	215	180	250	0	4-ø15	4	220	193	14	87	400	468
132S	2-8	265	230	300	0	4-ø15	4	260	223	14	102	465	553
132M	2-8	265	230	300	0	4-ø15	4	260	223	14	102	505	593
160M	2-8	300	250	350	0	4-ø19	5	315	265	15	146	608	726
160L	2-8	300	250	350	0	4-ø19	5	315	265	15	146	652	770
180M	2.4	300	250	350	0	4-ø19	5	360	280	15	161	690	808
180L	4-8	300	250	350	0	4-ø19	5	360	280	15	161	730	848
200L	2-8	350	300	400	0	4-ø19	5	400	310	17	186	760	878
225S	4-8	400	350	450	0	8-ø19	5	450	330	20	189	810	928
225M	2	400	350	450	0	8-ø19	5	450	330	20	189	805	923
	4-8	400	350	450	0	8-ø19	5	450	330	20	189	835	953
250M	2	500	450	550	0	8-ø19	5	485	375	22	207	910	1028
	4-8	500	450	550	0	8-ø19	5	485	375	22	207	910	1028
280S	2	500	450	550	0	8-ø19	5	550	405	22	215	985	1103
	4-8	500	450	550	0	8-ø19	5	550	405	22	215	1005	1153
280M	2	500	450	550	0	8-ø19	5	550	405	22	215	1030	1148
	4-8	500	450	550	0	8-ø19	5	550	405	22	215	1060	1208

R= distance from flange to shaft shoulder.

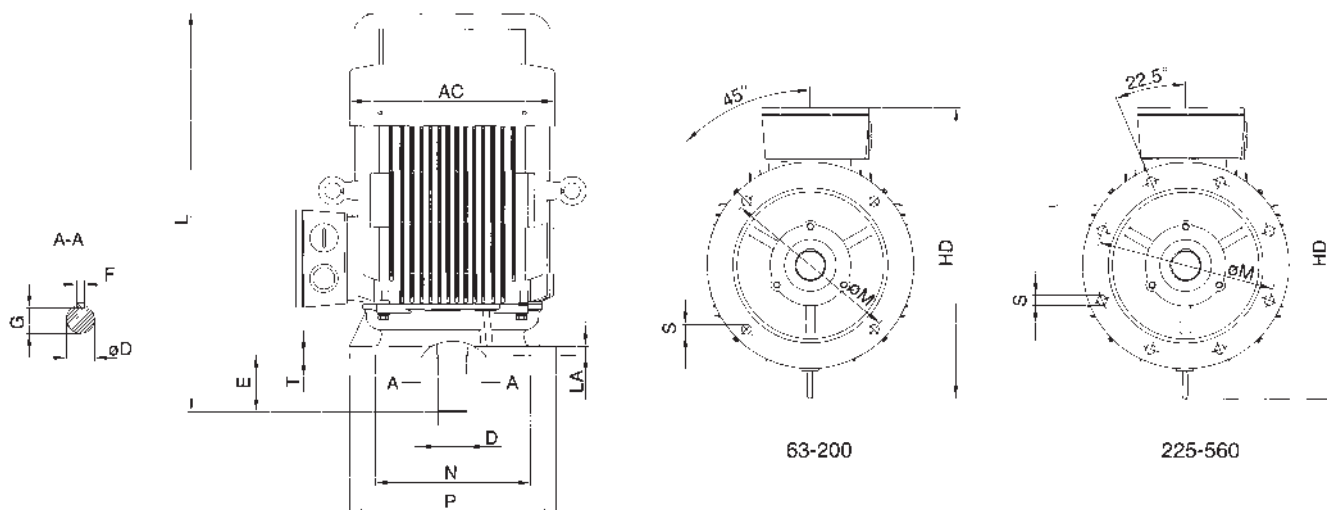

◆ V1

Frame	Pole	Dimension										Dimension				
		D	E	F	G	M	N	P	R	S	T	AC	HD	LA	LD	L
80	2-8	19	40	6	15.5	165	130	200	0	4- \emptyset 12	4	160	225	12	75	305
90S	2-8	24	50	8	20	165	130	200	0	4- \emptyset 12	4	180	245	12	75	345
90L	2-8	24	50	8	20	165	130	200	0	4- \emptyset 12	4	180	245	12	75	370
100L	2-8	28	60	8	24	215	180	250	0	4- \emptyset 15	4	200	280	13	83	410
112M	2-8	28	60	8	24	215	180	250	0	4- \emptyset 15	4	220	305	14	87	450
132S	2-8	38	80	10	33	265	230	300	0	4- \emptyset 15	4	260	365	14	102	510
132M	2-8	38	80	10	33	265	230	300	0	4- \emptyset 15	4	260	365	14	102	550
160M	2-8	42	110	12	37	300	250	350	0	4- \emptyset 19	5	315	445	15	146	660
160L	2-8	42	110	12	37	300	250	350	0	4- \emptyset 19	5	315	445	15	146	705
180M	2.4	48	110	14	42.5	300	250	350	0	4- \emptyset 19	5	360	480	15	161	750
180L	4-8	48	110	14	42.5	300	250	350	0	4- \emptyset 19	5	360	480	15	161	790
200L	2-8	55	110	16	49	350	300	400	0	4- \emptyset 19	5	400	530	17	186	840
225S	4-8	60	140	18	53	400	350	450	0	8- \emptyset 19	5	450	575	20	189	905
225M	2	55	110	16	49	400	350	450	0	8- \emptyset 19	5	450	575	20	189	910
	4-8	60	140	18	53	400	350	450	0	8- \emptyset 19	5	450	575	20	189	935
250M	2	60	140	18	53	500	450	550	0	8- \emptyset 19	5	485	635	22	207	1005
	4-8	65	140	18	58	500	450	550	0	8- \emptyset 19	5	485	635	22	207	1005
280S	2	65	140	18	58	500	450	550	0	8- \emptyset 19	5	550	725	22	215	1110
	4-8	75	140	20	67.5	500	450	550	0	8- \emptyset 19	5	550	725	22	215	1130
280M	2	65	140	18	58	500	450	550	0	8- \emptyset 19	5	550	725	22	215	1155
	4-8	75	140	20	67.5	500	450	550	0	8- \emptyset 19	5	550	725	22	215	1185
315S	2	65	140	18	58	600	550	660	0	8- \emptyset 24	6	625	895	22	257	1340
	4-8	80	170	22	71	600	550	660	0	8- \emptyset 24	6	625	895	22	257	1370
315M	2	65	140	18	58	600	550	660	0	8- \emptyset 24	6	625	895	22	257	1450
315L	4-8	80	170	22	71	600	550	660	0	8- \emptyset 24	6	625	895	22	257	1480
355M	2	75	140	20	67.5	740	680	800	0	8- \emptyset 24	6	700	970	25	284	1665
355L	4-8	100	210	25	86	740	680	800	0	8- \emptyset 24	6	700	970	25	284	1700
400M	2	80	170	22	71	940	880	1000	0	8- \emptyset 28	6	860	1150	25	362	2150
400L	4-8	110	210	28	100	940	880	1000	0	8- \emptyset 28	6	860	1150	25	362	2220

R= distance from flange to shaft shoulder.

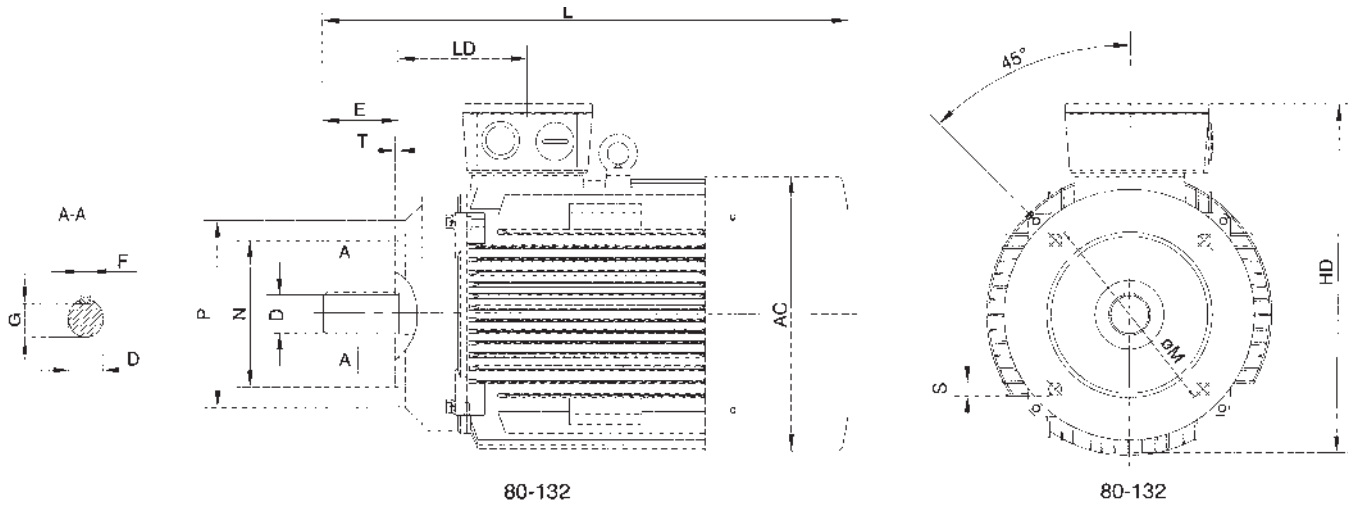

◆ B14A

Frame size	Pole	Mounting dimensions (mm)										Overall dimensions (mm)			
		D	E	F	G	M	N	P	R	S	T	AC	HD	LD	L
63	2.4	11	23	4	8.5	75	60	90	0	4-M5	2.5	125	185	65	225
71	2.4.6	14	30	5	11	85	70	105	0	4-M6	2.5	140	200	70	250
80	2-12	19	40	6	15.5	100	80	120	0	4-M6	3	160	225	75	280
90S	2-12	24	50	8	20	115	95	140	0	4-M8	3	175	245	75	315
90L	2-12	24	50	8	20	115	95	140	0	4-M8	3	175	245	75	340
100L	2-12	28	60	8	24	130	110	160	0	4-M8	3.5	200	280	83	375
112M	2-12	28	60	8	24	130	110	160	0	4-M8	3.5	225	305	87	400
132S	2-12	38	80	10	33	165	130	200	0	4-M10	4	260	365	102	465
132M	2-12	38	80	10	33	165	130	200	0	4-M10	4	260	365	102	505

◆ B14B

Frame size	Pole	Mounting dimensions (mm)										Overall dimensions (mm)			
		D	E	F	G	M	N	P	R	S	T	AC	HD	LD	L
63	2.4	11	23	4	8.5	100	80	120	0	4-M6	3	125	185	65	225
71	2.4.6	14	30	5	11	115	95	140	0	4-M8	3	140	200	70	250
80	2-12	19	40	6	15.5	130	110	160	0	4-M8	3.5	160	225	75	280
90S	2-12	24	50	8	20	130	110	160	0	4-M8	3.5	175	245	75	315
90L	2-12	24	50	8	20	130	110	160	0	4-M8	3.5	175	245	75	340
100L	2-12	28	60	8	24	165	130	200	0	4-M10	3.5	200	280	83	375
112M	2-12	28	60	8	24	165	130	200	0	4-M10	3.5	225	305	87	400
132S	2-12	38	80	10	33	215	180	250	0	4-M12	4	260	365	102	465
132M	2-12	38	80	10	33	215	180	250	0	4-M12	4	260	365	102	505

R= distance from flange to shaft shoulder.

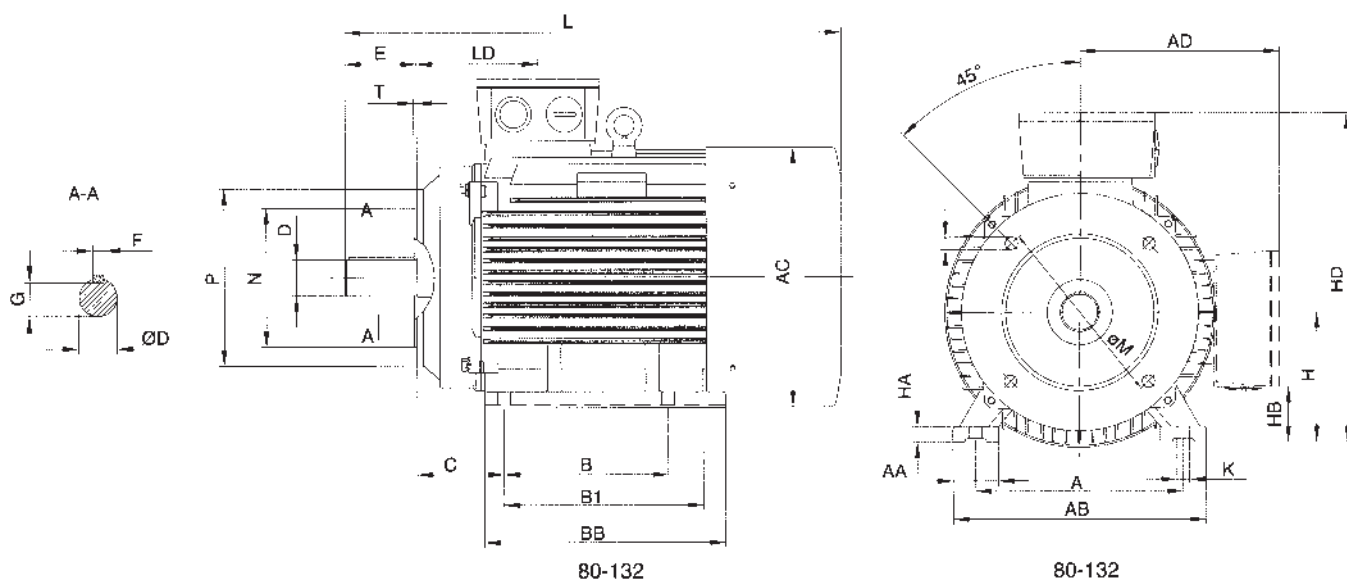

◆ B34

Frame size	Pole	Mounting dimensions (mm)															Overall dimensions (mm)				
		A	B	C	D	E	F	G	H	K	M	N	P	R	S	T	AB	AC	AD	HD	L
63M	2.4	100	80	40	11	23	4	8.5	63	7	75	60	90	0	4-M5	2.5	135	125	-	185	225
71M	2.4.6	112	90	45	14	30	5	11	71	7	85	70	105	0	4-M6	2.5	150	140	-	200	250
80M	2-12	125	100	50	19	40	6	15.5	80	10	100	80	120	0	4-M6	3	160	160	145	225	280
90S	2-12	140	100	56	24	50	8	20	90	10	115	95	140	0	4-M8	3	180	175	155	245	315
90L	2-12	140	125	56	24	50	8	20	90	10	115	95	140	0	4-M8	3	180	175	155	245	340
100L	2-12	160	140	63	28	60	8	24	100	12	130	110	160	0	4-M8	3.5	200	200	180	270	375
112M	2-12	190	140	70	28	60	8	24	112	12	130	110	160	0	4-M8	3.5	230	225	190	305	400
132S	2-12	216	140	89	38	80	10	33	132	12	165	130	200	0	4-M10	4	265	260	210	345	465
132M	2-12	216	178	89	38	80	10	33	132	12	165	130	200	0	4-M10	4	265	260	210	345	505

◆ B34

Frame size	Pole	Mounting dimensions (mm)															Overall dimensions (mm)				
		A	B	C	D	E	F	G	H	K	M	N	P	R	S	T	AB	AC	AD	HD	L
63M	2.4	100	80	40	11	23	4	8.5	63	7	100	80	120	0	4-M6	3	135	125	-	185	225
71M	2.4.6	112	90	45	14	30	5	11	71	7	115	95	140	0	4-M8	3	150	140	-	200	250
80M	2-12	125	100	50	19	40	6	15.5	80	10	130	110	160	0	4-M8	3.5	160	160	145	225	280
90S	2-12	140	100	56	24	50	8	20	90	10	130	110	160	0	4-M8	3.5	180	175	155	245	315
90L	2-12	140	125	56	24	50	8	20	90	10	130	110	160	0	4-M8	3.5	180	175	155	245	340
100L	2-12	160	140	63	28	60	8	24	100	12	165	130	200	0	4-M10	3.5	200	200	180	270	375
112M	2-12	190	140	70	28	60	8	24	112	12	165	130	200	0	4-M10	3.5	230	225	190	305	400
132S	2-12	216	140	89	38	80	10	33	132	12	215	180	250	0	4-M12	4	265	260	210	345	465
132M	2-12	216	178	89	38	80	10	33	132	12	215	180	250	0	4-M12	4	265	260	210	345	505

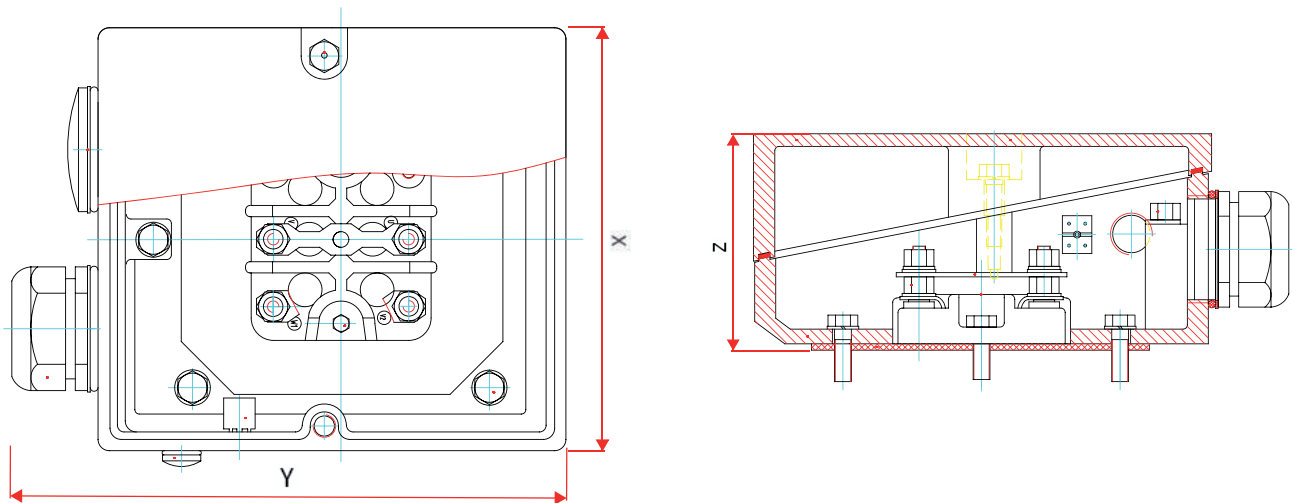

Frame size	Dia.of the gland mm	X x Y x Z
63~71	1-M20x1.5	95x95x50
80~100	2-M25x1.5	106x108x65
112~132	2-M32x1.5	124x128x78
160~180	2-M40x1.5	158x168x90
200~225	2-M50x1.5	196x216x105
250~280	2-M63x1.5	226x226x124
315	2-M63x1.5	303x303x170
355	2-M72x2.0	360x485x200
400	7-M63x1.5	430x545x275

CUSCINETTI - BEARINGS

B3 B35 B5 V1						
Frame size	Driving End			Non-driving End		
	2 pole	4 pole	>6 pole	2 pole	4 pole	>6 pole
80	6204ZZ	6204ZZ	6204ZZ	6204ZZ	6204ZZ	6204ZZ
90	6205ZZ/C3	6205ZZ/C3	6205ZZ	6205ZZ/C3	6205ZZ/C3	6205ZZ
100	6206ZZ/C3	6206ZZ/C3	6206ZZ/C3	6206ZZ/C3	6206ZZ/C3	6206ZZ/C3
112	6306ZZ/C3	6306ZZ/C3	6306ZZ/C3	6306ZZ/C3	6306ZZ/C3	6306ZZ/C3
132	6308ZZ/C3	6308ZZ/C3	6308ZZ/C3	6308ZZ/C3	6308ZZ/C3	6308ZZ/C3
160	6309ZZ/C3	6309ZZ/C3	6309ZZ/C3	6309ZZ/C3	6309ZZ/C3	6309ZZ/C3
180	6311ZZ/C3	6311ZZ/C3	6311ZZ/C3	6311ZZ/C3	6311ZZ/C3	6311ZZ/C3
200	6312ZZ/C3	6312ZZ/C3	6312ZZ/C3	6312ZZ/C3	6312ZZ/C3	6312ZZ/C3
225	6313ZZ/C3	6313ZZ/C3	6313ZZ/C3	6313ZZ/C3	6313ZZ/C3	6313ZZ/C3
250	6314C3	6314C3	6314C3	6314C3	6314C3	6314C3
280	6314C3	6317C3	6317C3	6314C3	6317C3	6317C3
315	6317C3	6319C3	6319C3	6317C3	6319C3	6319C3
355	6317C3	6322C3	6322C3	6317C3	6320C3	6320C3
400	6317C3	6326C3	6326C3	6317C3(7317B)	6326C3(7319B)	6326C3(7319B)

V1						
Frame size	Driving End			Non-driving End		
	2 pole	4 pole	>6 pole	2 pole	4 pole	>6 pole
315	6317C3	6319C3(NU319)	6319C3(NU319)	6317 (7317)	6319 (7317)	6319 (7319)
355	6319C3	6322C3(NU322)	6322C3(NU322)	6319 (7317)	6320 (7317)	6320 (7320)
400	6317C3	6326C3(NU326)	6326C3(NU326)	6319 (7317)	6326 (7317)	6326 (7326)

VIBRAZIONI - VIBRATION

Frame size	≤132		>132~225		>225~400	
Synchronous Speed r/min	600~1800	>1800~3600	600~1800	>1800~3600	500~1800	>1800~3600
Vibration Class	Effective Value of speed mm/s					
N	1.8		2.8		3.5	
R	0.71	1.12	1.12	1.80	1.80	2.80
S	0.45	0.71	0.71	1.12	1.12	1.80

RUMOROSITA (50Hz) NOISE (50Hz)

Output (kW)	Synchronous Speed r/min					
	3000	1500	1000	750	600	500
	Lp dB(A) Sound perssure level in dB(A)					
	no load	no load	no load	no load	no load	no load
0.09	/	/	/	/	40	/
0.12	/	45	/	/	40	/
0.18	50	45	45	42	40	/
0.25	50	46	45	42	40	40
0.37	54	46	46	44	40	44
0.55	54	47	46	44	40	44
0.75	57	47	48	45	43	48
1.1	57	51	48	45	43	54
1.5	62	51	52	48	48	54
2.2	62	52	54	50	50	60
3	66	52	57	51	55	60
4	67	55	57	56	55	60
5.5	70	57	57	56	58	62
7.5	70	57	61	57	58	62
11	76	62	61	59	60	65
15	76	62	61	60	60	69
18.5	76	64	65	62	60	72
22	79	65	65	62	64	72
30	81	66	65	64	64	75
37	81	70	66	65	64	75
45	81	70	68	65	66	75
55	82	72	68	66	66	75
75	83	75	70	66	66	72
90	84	75	70	67	66	72
110	86	78	71	67	68	72
132	86	78	71	72	68	75
160	87	80	72	72	68	75
200	87	80	73	73	68	75
250	90	84	73	73	68	75
315	90	84	76	75	68	75
355	90	84	76	75	70	75
400	94	87	76	75	70	75
450	94	87	76	77	70	75
500	94	89	76	77	72	75
560*	94	89	79	78	72	75
630*	94	91	79	78	72	/
710*	94	92	79	79	74	/
800*	96	92	82	79	74	/
900*	96	92	82	79	74	/
1000*	96	92	82	80	/	/
1120*	96	94	84	80	/	/
1250*	96	94	84	80	/	/
1400*	96	94	84	/	/	/

* a richiesta
* on request

**DIMENSIONE ALBERO
SERIE GHISA**

**DIMENSION SHAF
CAST IRON SERIES**

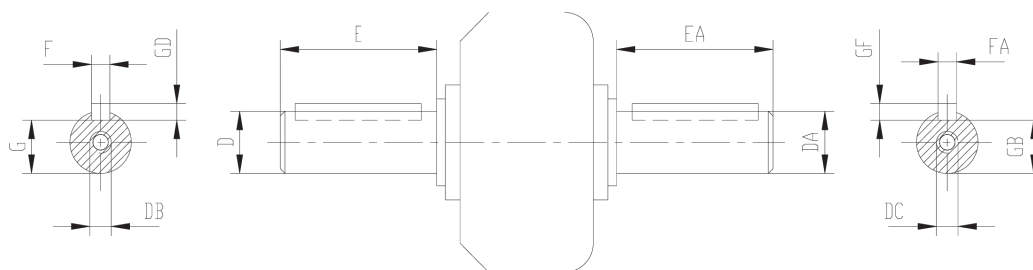

Frame	Pole	D	DA	E	EA	F	FA	G	GB	GD	GF	DB	DC
56	2-4	9 j6(+0.007 -0.002)	9 j6(+0.007 -0.002)	20	20	3	3	7	7	3	3	M3	M3
63	2-4	11 j6(+0.008 -0.003)	11 j6(+0.008 -0.003)	23	23	4	4	8.5	8.5	4	4	M4	M4
71	2-4-6	14 j6(+0.008 -0.003)	14 j6(+0.008 -0.003)	30	30	5	5	11	11	5	5	M5	M5
80	2-4-6-8	19 j6(+0.009 -0.004)	19 j6(+0.009 -0.004)	40	40	6	6	15.5	15.5	6	6	M6	M6
90S	2-4-6-8	24 j6(+0.009 -0.004)	24 j6(+0.009 -0.004)	50	50	8	8	20	20	7	7	M8	M8
90L	2-4-6-8												
100L	2-4-6-8	28 k6(+0.009 -0.004)	28 k6(+0.009 -0.004)	60	60	8	8	24	24	7	7	M10	M10
112M	2-4-6-8												
132S	2-4-6-8	38 k6(+0.018 -0.002)	38 k6(+0.018 -0.002)	80	80	10	10	33	33	8	8	M12	M12
132M	2-4-6-8												
160M	2-4-6-8	42 k6(+0.018 -0.002)	42 k6(+0.018 -0.002)	110	110	12	12	37	37	9	9	M16	M16
160L	2-4-6-8												
180M	2-4	48 k6(+0.018 -0.002)	48 k6(+0.018 -0.002)	110	110	14	14	42.5	42.5	9	9	M16	M16
180L	4-6-8												
200L	2	55 m6(+0.03 -0.011)	48 k6(+0.018 -0.002)	140	140	16	14	49	42.5	10	9	M20	M20
	4-6-8												
225S	4-6-8	60 m6(+0.03 -0.011)	55 m6(+0.03 -0.011)	140	140	18	16	53	49	11	10	M20	M20
225M	2	55 m6(+0.03 -0.011)	48 k6(+0.018 -0.002)	110	110	16	14	49	42.5	10	9	M20	M20
	4-6-8												
250M	2	60 m6(+0.03 -0.011)	60 m6(+0.03 -0.011)	140	140	18	16	53	49	11	10	M20	M20
	4-6-8												
280S	2	65 m6(+0.03 -0.011)	65 m6(+0.03 -0.011)	140	140	18	18	58	49	11	10	M20	M20
	4-6-8												
280M	2	65 m6(+0.03 -0.011)	55 m6(+0.03 -0.011)	140	140	18	16	58	49	11	10	M20	M20
	4-6-8												
315S	2	65 m6(+0.03 -0.011)	65 m6(+0.03 -0.011)	140	140	18	18	58	58	11	11	M24	M24
	4-6-8												
315M	2	65 m6(+0.03 -0.011)	65 m6(+0.03 -0.011)	140	140	18	18	58	58	11	11	M24	M24
315L	4-6-8	80 m6(+0.03 -0.011)	80 m6(+0.03 -0.011)	170	170	22	22	71	71	14	14	M24	M24
355M	2	75 m6(+0.03 -0.011)	75 m6(+0.03 -0.011)	140	140	20	20	67.5	67.5	12	12	M24	M24
	4-6-8												
355L	2	75 m6(+0.03 -0.011)	75 m6(+0.03 -0.011)	140	140	20	20	67.5	67.5	12	12	M24	M24
	4-6-8												
400M	2	80 m6(+0.03 -0.011)	80 m6(+0.03 -0.011)	170	170	22	22	71	71	14	14	M24	M24
400L	4-6-8	110 m6(+0.035 -0.013)	110 m6(+0.035 -0.013)	210	210	28	28	100	100	16	16	M24	M24

LISTA COMPONENTI – RICAMBI MOTORI IN GHISA
LIST OF COMPONENTS - SPARE PARTS CAST IRON MOTORS

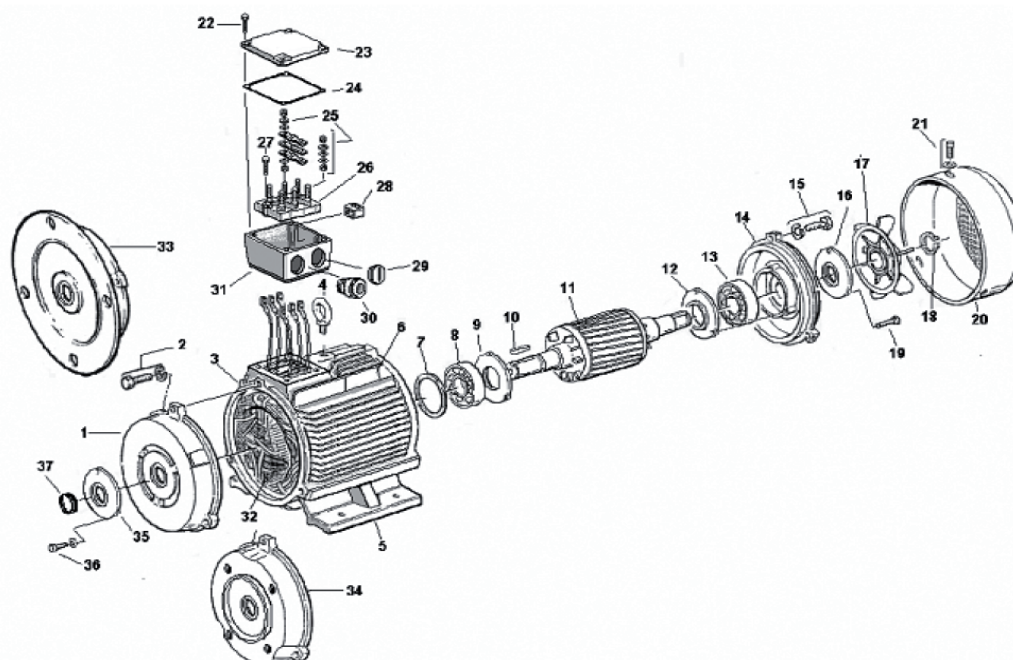

- | | |
|---|--|
| 1 Scudo lato DE (B3) - Shield B3 DE | 19 Bullone coperchietto cuscinetto NDE - Bolt bearing cap NDE |
| 2 Bullone fissaggio scudo DE - Fixing bolt shield DE | 20 Calotta copri ventola - Fan cover |
| 3 Carcassa statore - Stator frame | 21 Vite calotta copri ventola - Fan cover screw |
| 4 Golfare - Eye bolt | 22 Vite scatola morsetti - Terminal box screw |
| 5 Piede (in fusione)- Feet (in casting) | 23 Coperchio scatola morsetti - Terminal box cover |
| 6 Targa dati - Nameplate | 24 Guarnizione scatola morsetti - Terminal box gasket |
| 7 Ranella anti allentamento - Spring washer | 25 Dadi fissaggio cavi - Connection fixation nuts |
| 8 Cuscinetto lato DE - Bearing DE | 26 Basetta - Terminal board |
| 9 Coperchietto interno cuscinetto DE dalla taglia 180 - Inner Bearing cap DE from size 180 | 27 Dadi fissaggio basetta - Terminal board holder bolt |
| 10 Chiavetta - Key | 28 Morsetti termistori (PTC) - Terminal block (PTC) |
| 11 Pacco rotore - Rotor Core | 29 Tappo protezione - Blinder |
| 12 Coperchietto interno cuscinetto NDE dalla taglia 180 - Inner bearing cap NDE from size 180 | 30 Pressacavo - Cable gland |
| 13 Cuscinetto NDE - Bearing NDE | 31 Scatola morsetti - Terminal box |
| 14 Scudo NDE - Shield NDE | 32 Avvolgimenti - Windings |
| 15 Bullone fissaggio scudo NDE - Fixing bolt shield NDE | 33 Flangia B5 - Flange B5 |
| 16 Coperchietto esterno cuscinetto NDE dalla taglia 180 - Outer bearing cap NDE from size 180 | 34 Flangia B14 - Flange B14 |
| 17 Ventola - Fan | 35 Coperchietto esterno cuscinetto DE - Bearing cap DE outside |
| 18 Anello elastico - Circlip | 36 Bullone di fissaggio Fixing bolt |
| | 37 Tenuta - Seal |

**CARICHI ASSIALI AMMESSI.
PERMISSIBLE AXIAL LOADS.**

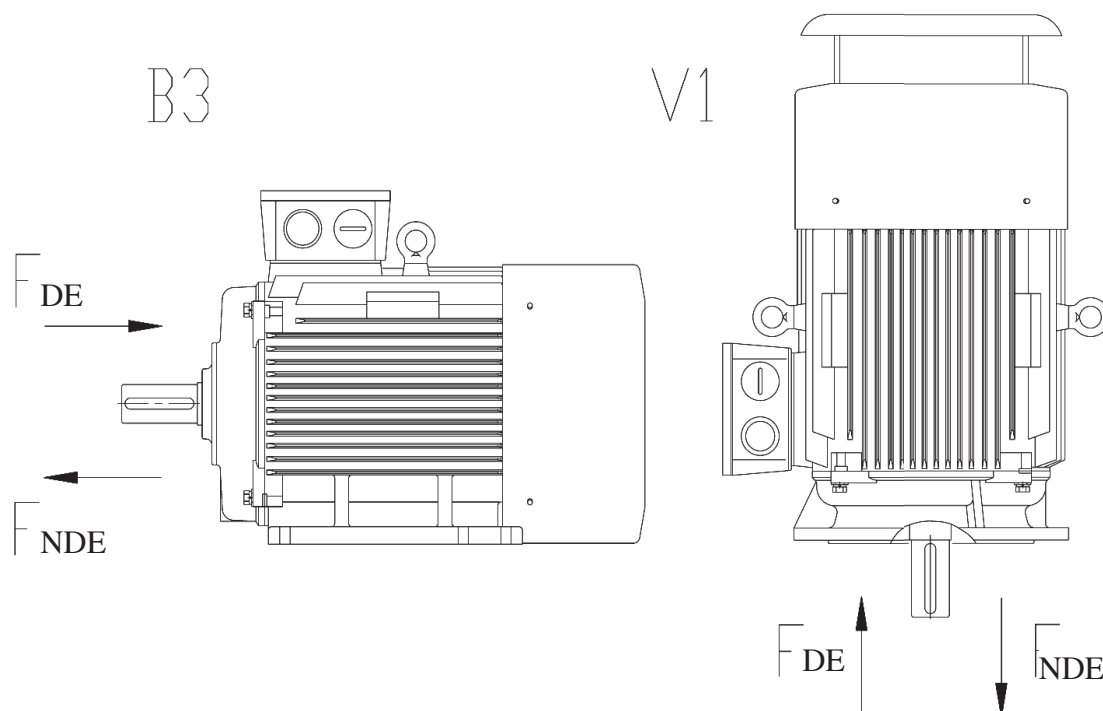

La seguente tabella fornisce le forze assiali ammissibili in Newton, assumendo come zero forza radiale. In questo caso il motore deve essere ordinato con cuscinetti a sfere standard. In caso di forze assiali superiori ai valori riportati nella tabella devono essere ordinati motori con cuscinetto a contatto angolare. I valori si basano su condizioni normali a 50Hz. e calcolato a 20000 ore di lavoro per motori a 2 poli e 40000 ore per i motori 4, 6 e 8 poli. A 60Hz. i valori devono essere ridotti del 10%. Per i motori a due velocità i valori devono essere basati presso la velocità più elevata.
Fpressione (D.E.) è calcolata per un cuscinetto fisso sul lato comando.

The following table gives the permissible axial forces in Newton, assuming zero radial force. In this case motor should be ordered with standard ball bearings. In case of higher axial force than given in the table an angular contact bearing should be ordered. The values are based on normal conditions at 50Hz. and calculated at 20000 working hour for two pole motors and 40000 hours for 4, 6 and 8 pole motors. At 60Hz. the values must be reduced by 10%. For two-speed motors the values have to be based at the higher speed.
Fpressure (D.E.) is calculated for a fixed bearing at the Drive End.

Frame Size	pole	Maximum axial force (FA)				Frame Size	pole	Maximum axial force (FA)			
		B3 FDE	B3 FNDE	V1 FDE	V1 FNDE			B3 FDE	B3 FNDE	V1 FDE	V1 FNDE
56	2	200	200	230	180	180	2	2100	2100	2450	1720
	4	240	240	260	200		4	2600	2600	3200	2000
63	2	250	250	260	230		6	2900	2900	3510	2280
	4	280	280	300	260	8	3170	3170	3780	2550	
71	2	270	270	290	255	200	2	2400	2400	2940	1840
	4	350	350	370	320		4	3120	3120	3850	2390
	6	440	440	460	420		6	3480	3480	4350	2610
80	2	380	380	400	360	225	8	3950	3950	4810	3090
	4	470	470	490	450		2	2720	2720	3420	2020
	6	590	590	620	560		4	3480	3480	4370	2590
	8	620	620	650	595		6	3890	3890	5040	2820
90	2	440	440	470	410	250	8	4330	4330	5330	3330
	4	550	550	600	510		2	3100	3100	3940	2260
	6	620	620	680	460		4	3900	3900	5000	2800
	8	640	640	700	580		6	4450	4450	5570	3230
100	2	610	610	670	570	280	8	4980	4980	6380	3580
	4	750	750	840	710		2	5300	3100	6500	2100
	6	880	880	970	820		4	6300	4400	7800	3000
	8	895	895	970	845		6	6700	4300	7900	2900
112	2	1220	1220	1300	1170	315	8	7100	5020	9100	3520
	4	1440	1440	1520	1370		2	5900	3800	8000	2000
	6	1650	1650	1740	1580		4	7100	5100	10700	3150
	8	1780	1780	1880	1710		6	7600	5800	11800	3500
132	2	1500	1500	1620	1430	355*	8	8100	6300	12500	4400
	4	1780	1780	1970	1610		2	6100	1850	14000	800
	6	1820	1820	2000	1660		4	9800	3900	18300	2500*
	8	1920	1920	2100	1760		6	10500	4700	20700	3500*
160	2	1650	1650	1950	1350	400*	8	12500	6000	21500	3600*
	4	2100	2100	2470	1720		4	11200	3900	18500	1600*
	6	2450	2450	2800	2050		6	12500	4800	19500	2200*
	8	2650	2650	3050	2210		8	12800	4950	21500	2900*

*= Dati calcolati con cuscinetti a rulli

*= Data calculated with roll bearings

Per forme costruttive diverse e/o carichi diversi contattare FELM

Consult FELM for other mounting or different loads

CARICHI RADIALI AMMESSI. PERMISSIBLE RADIAL LOADS.

La seguente tabella fornisce le forze assiali ammissibili in Newton, assumendo come zero forza radiale. In questo caso il motore deve essere ordinato con cuscinetti a sfere standard. In caso di forze assiali superiori ai valori riportati nella tabella devono essere ordinati motori con cuscinetto a contatto angolare. I valori si basano su condizioni normali a 50Hz. e calcolato a 20000 ore di lavoro per motori a 2 poli e 40000 ore per i motori 4, 6 e 8 poli. A 60Hz. i valori devono essere ridotti del 10%. Per i motori a due velocità i valori devono essere basati presso la velocità più elevata. Fpressure (D.E.) è calcolata per un cuscinetto fisso sul lato comando.

The following table give the permissible radial forces in Newton, assuming zero axial force and standard ball bearings. In case of higher radial force than give in the table an enforced bearing should be ordered. The values are based on normal conditions at 50 Hz and calculated at 20 000 working hours for the two pole motors and 40 000 working hours for 4,6 and 8 poles. For 60 Hz the value must be reduced by 10%. For two speed motors, the values have to be based at the higher speed.

Diametro puleggio:
Pulley diameter:

Quando la durata del cuscinetto desiderato è stato determinato, il diametro della puleggia minimo può essere calcolato con la seguente formula:
When the desired bearing life has been determined, the minimum pulley diameter can be calculated with the following formula:

$$D_{min} = \frac{1.9 \times 10^7 \times k \times P_N}{n_N \times F_R}$$

D_{min} = diameter of the pulley (mm)

P = power of the motor (kW)

n = motor rated speed(r/min)

K = belt tension factor , $k=2.5$ for V-belt

$F_R(X)$ = permissible radial force (N)

$$F_R = F_{R0} - \frac{X}{E} (F_{R0} - F_{RMAX})$$

E = the length of the shaft diameter (mm.) in basic version

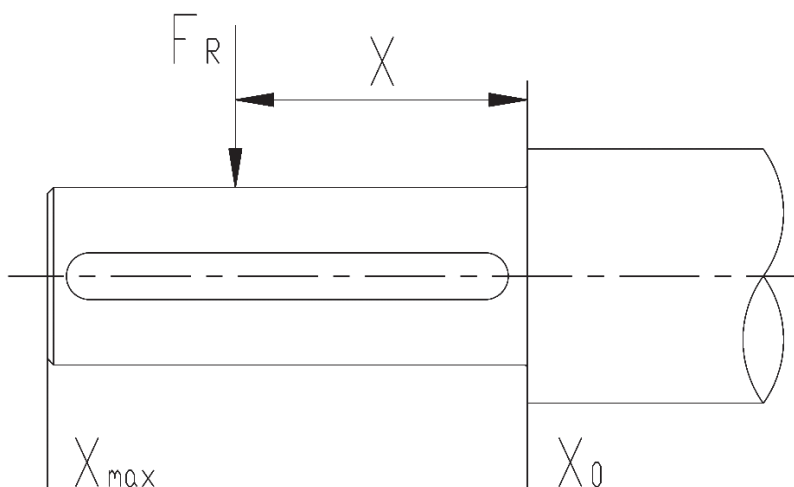

Size	pole	Maximum radial force (F_R)		
		X0	X1/2	Xmax
56	2	250	180	100
	4	250	180	100
63	2	360	300	230
	4	360	300	230
71	2	470	400	320
	4	470	400	320
	6	470	400	320
80	2	670	610	550
	4	730	650	590
	6	830	750	680
	8	920	820	750
90	2	740	660	590
	4	800	710	630
	6	920	810	730
	8	1010	890	800
100	2	1030	920	820
	4	1110	990	890
	6	1270	1130	1020
	8	1400	1240	1120
112	2	1490	1330	1200
	4	1600	1430	1290
	6	1840	1640	1480
	8	2020	1800	1630
132	2	2160	1900	1690
	4	2330	2040	1820
	6	2670	2340	2080
	8	2940	2570	2290
160	2	2800	2440	2170
	4	3000	2630	2330
	6	3440	3010	2670
	8	3850	3410	3060

Frame Size	pole	Maximum radial force (F_R)		
		X0	X1/2	Xmax
180	2	3930	3500	3150
	4	4240	3770	3390
	6	4890	4390	3980
200	8	5380	4830	4380
	2	4480	4050	3700
	4	4820	4360	3980
	6	5520	5000	4560
225	8	6080	5500	5020
	2	5000	4540	4160
	4	5360	4720	4210
	6	6180	5480	4920
250	8	6750	5940	5310
	2	5680	5100	4620
	4	6120	5490	4980
	6	7000	6280	5700
280	8	7710	6920	6270
	2	5620	5080	4640
	4	7790	7050	6430
	6	8920	8060	7360
315	8	9820	8880	8100
	2	7370	6840	6390
	4	9150	8370	7720
	6	10480	9590	8830
355*	8	11530	10550	9720
	2	16330	15390	8730
	4	28300	25860	14290
	6	32400	29600	16350
400*	8	35660	32580	18000
	4	33730	31140	19280
	6	38610	35650	22070
	8	42500	39240	24290

Tutti i dati (tecnici, dimensionali, ecc.) riportati nelle tabelle sono indicativi e non impegnativi. I valori garantiti vengono rilasciati su richiesta. Con l'obiettivo di un continuo sviluppo del Prodotto Motore Elettrico, FELM srl si riserva il diritto di modificare il progetto, le caratteristiche tecniche e dimensionali in qualsiasi momento senza preavviso.

All data (technical, dimensions, etc.) listed in the tables are indicative and not binding. The guaranteed values are upon request. Felm srl reserves the right to change the project, the technical characteristics and dimensions at any time without previous notice.

Contact Us

Head Quarter

FELM srl
Via Morandi 1 (Industrial Area)
20001 Inveruno (MI)
Tel +39 0297289454
Tel +39 0297288320
Fax +39 0297289923
e-mail: home@felm.it

FELM Office UK

The Foundry, Wadebridge
Cornwall, PL277PG
United Kingdom
Tel (Off): +441208 816543
Mobile: +447791717488
Email: Toby@felm.co.uk

AVAILABLE 24/24 EVERY DAY

We operate on all the continents:
thanks to our partner we can
guaranteeing a complete
international service.

WORLD WIDE SERVICE

Mobile +39 335 69 53 804
e-mail: service@felm.it

FELM Office Germany

Heinrich-Busold-Strasse 47
D-61169 Friedberg (Hessen),
Germany
Tel (Off): +49-6031-721606
Mobile: +49-172-6729011
Fax: +49-6031-721610
Email: Jayant@jk-conrep.de

FELM Office China

Add: Room 1002, Building 3#,
No 139 Rd. SongShan,
Jianye, Nanjing, Jiangsu, China
Fax: +86-25-87797622
Tel: +86-15077829999
Email:
lidongming1974@vip.sina.com

FELM Office Middle East

Al Saalam Street, Al Darwish
Building (NBAD building)
office no. 1403 Abu Dhabi (United
Arab Emirates) P.O. Box 45223
Office Ph. + 971-2-6710330
Office Fax + 971-2-6710255
mobile +971 50 4442093
Email: ayman.abdallah@felm.it





FELM srl

Uffici via Varese 17 - Inveruno (Mi) Italy - Tel. 0039 (0)2 97 288 320 - home@felm.it
Magazzini Via Morandi Z.I. - Inveruno (Mi) Italy - Tel. 0039 (0)2 97 289 454 - magazzini@felm.it
Service Varese 34 - Inveruno (Mi) Italy - Tel. 0039 (0)2 97 288 320 - service@felm.it



Electric Motors High Efficiency



IE3

PREMIUM EFFICIENCY





INTRODUCTION

The conservative and responsible use of energy to save resources, to reduce the amount of CO₂ emissions and to decrease energy costs is the order of the day. The electrical drive system plays a key role in this process. Electrical drives form the link between the electrical energy supply and the majority of mechanical processes, which require a large amount of energy. Machines driven by electrical motors consume 2/3 of all the electrical energy used in industry. If the old systems in German industry, commerce and public facilities, which have been running for decades, were all replaced by modern drive systems, this would result in annual energy savings of 38 billion kilowatt hours. Calculated for all of Europe, this figure would be 135 billion kilowatt hours.

By using electronic speed control and Energy efficient motors, Europe's CO₂ emissions could be reduced by 69 million tonnes.

This brochure describes the new standardised international efficiency classes for standard three-phase motors, the new measuring methods and the requirements stipulated by the European Regulation 640/2009 of the European Commission for energy efficiency in motors and drive systems.

This brochure also offers an overview of some of the world-wide existing national legislation and addresses subjects like material composition and life cycle cost.

The catalogue is written for users, original equipment manufacturers (OEM), machine manufacturers and motor and drive system manufacturers.

Efficiency Classes of Motors and Measuring Methods

The "efficiency" describes how efficiently an electric motor transforms electrical energy into mechanical energy. Previously in Europe, low voltage three-phase motors have been graded and marketed in three efficiency classes – EFF3, EFF2 and EFF1 – based on a voluntary agreement between motor manufacturers and the European Commission.

This classification system is well proven and has now been adapted in many countries around the world. Unfortunately, other countries have also developed their own national systems, which are very different from the European system. That was the reason for the German motor manufacturers in ZVEI, with the support of their European neighbours, to develop an energy efficiency standard for the International Electrotechnical Commission (IEC).

The objective was to have a common international standard that replaces all the different national systems. This project was successful and the objective has been met.

The new international standard, IEC 60034-30:2008, defines efficiency classes IE1, IE2 and IE3 for three-phase motors.

This ensures a common international basis for the design and classification of motors as well as for national legislative activities. At the same time, the IEC developed improved methods for determining the efficiency of these motors.

The international standards IEC 60034-30:2008 (classification) and IEC 60034-2-1:2007 (measuring methods) have been adopted as European standards without any changes as EN 60034-30:2009 and EN 60034-2-1:2007.

For the sake of simplicity, the following sections will refer to the IEC standards only.

Previous efficiency classes of motors in Europe

In 1998, as part of the voluntary agreement between the European sector committee of Manufacturers of Electrical Machines and Power Electronics (CEMEP) and the European Commission, three efficiency classes were defined for the power range of 1.1 kW to 90 kW:

- EFF3 = Motors with a low efficiency level
- EFF2 = Motors with an improved efficiency level
- EFF1 = Motors with a high efficiency level

New international standard for efficiency classes of motors (IE-code)

This voluntary agreement has since expired. However, the efficiency classes remain a registered European trademark. Use of the efficiency classes is based on a contractual licensing agreement between the participants in the voluntary agreement (motor manufacturers) and the license holder (CEMEP / Gimelec). This licensing agreement expires on 10 February 2010, but can be extended to 15 June 2011 upon request.

Standard IEC 60034-30:2008 defines the efficiency classes for low voltage three-phase motors with a power range from 0.75 kW to 375 kW. "IE" stands for "International Efficiency" and is combined with a number:

IE1 = Standard efficiency

IE2 = High efficiency

IE3 = Premium efficiency

New IEC measuring methods

The new measuring methods in accordance with IEC 60034-2-1:2007 (standard methods for determining losses and efficiency from tests) apply for all motors described by IEC 60034-1. These methods help to generate more exact data regarding stray load loss. The new standard replaces the previous European standard EN 60034-2:1996, which expired on 1 November 2010. Motors that are marked according to the new efficiency class system (IE-code) are required to be measured using the new measurement methods.

Comparison of old and new efficiency classes

The new international efficiency class system (IE-code) has an open numbering system. Compared to the old EFF efficiency classes, it is now easier to add future developments. In addition, there is a new class – IE3 – which did not exist in the old European EFF classification system.

The scope has also been extended significantly; the new IE-code applies to a larger power range as well as for the 60 Hz classes e.g. in the USA.

The main difference between the efficiency classes (EFF and IE) lies in the method used to determine them. In a direct comparison at the same motor, it is expected that the efficiency determined according to the new measuring method will be lower. For example, an 11 kW, 4-pole EFF1 motor with 91.0% efficiency is physically identical with a IE2 motor with 89.8% efficiency.

Scope of new IEC efficiency class system (IE-code)

The efficiency class system specified under IEC 60034-30 is valid for low voltage three-phase cage induction motors with the following specifications:

- Rated voltage up to 1,000 V
- Rated output between 0.75 kW and 375 kW
- Either 2, 4 or 6 poles
- Rated on the basis of continuous duty (S1) or intermittent periodic duty (S3) with cyclic duration factor of 80% or higher;
- Capable of operating direct on-line
- Rated for operating conditions in accordance with IEC 60034-1 (temperature, installation altitude, etc.)

Motors with flanges, feet and/or shafts with mechanical dimensions different from IEC 60072-1 are covered by this standard.

Geared motors and brake motors are covered by this standard, although special shafts and flanges may be used in such motors.

Some motors covered by this standard may be equipped with auxiliary devices. However, as long as these auxiliary devices are not an integral part of the motor construction, the determination of efficiency in all possible combinations is not practical. Determinations for efficiency of such modified standard motors shall be performed on basic motors without auxiliary devices installed. The following are exceptions to the classification system:

- Motors for short-time duty (S2) or switching operation (S3 < 80% to S10);
- Motors that were solely designed for converter operation (VSD) in accordance with IEC 60034-25 as well as
- Motors that have a highly specialized design customized for one particular application in such a way that it is not possible to measure the motor on its own (for example pump motors with wet rotors).

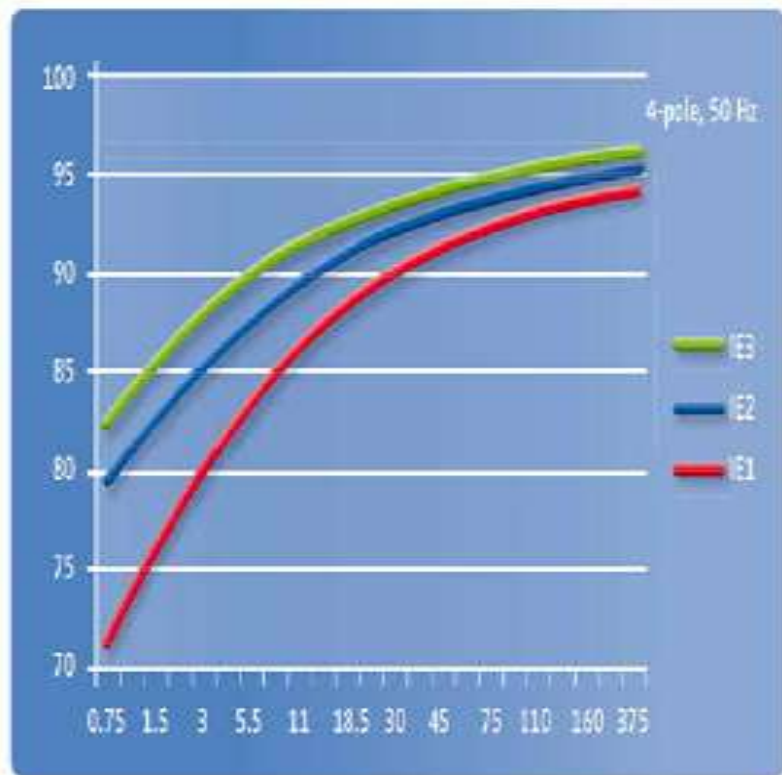

IE3 ALUMINIUM HOUSING - TECHNICAL DATA

TYPE	Power KW	RPM r/min	Voltage		Amp	Amp	Efficiency 100%	Efficiency 75%	Efficiency 50%	Power Factor cosφ 100 %	Locked Current Is/In	Locked Torque Ts/Tn	Locked Torque Tm/Tn	Moment of inertia Kgm2	Weight Kg.
			230	400											
FA3-80 1-2	0,75	2820	230	400	2,82	1,63	80,7	81,0	79,7	0,831	6,0	2,3	2,3	0,001	9,5
FA3-80 2-2	1,1	2820	230	400	4,00	2,30	82,7	82,9	81,5	0,836	7,5	2,3	2,3	0,002	11
FA3-90S-2	1,5	2840	230	400	5,23	3,02	84,2	85,0	84,0	0,857	7,5	2,4	2,4	0,002	15
FA3-90L-2	2,2	2840	230	400	7,44	4,30	85,9	86,5	86,0	0,865	7,5	2,4	2,4	0,003	18
FA3-100L-2	3	2850	230	400	9,90	5,72	87,1	87,3	86,2	0,873	8,0	2,4	2,4	0,005	25
FA3-112M-2	4	2870	400	690	7,48	4,32	88,1	88,4	88,0	0,88	8,5	2,4	2,4	0,008	28,5
FA3-132S1-2	5,5	2900	400	690	10,00	5,80	89,2	89,6	89,1	0,89	7,5	2,2	2,4	0,014	41
FA3-132S2-2	7,5	2900	400	690	13,50	7,80	90,1	90,5	90,0	0,892	7,5	2,2	2,4	0,017	46,5

TYPE	Power KW	RPM r/min	Voltage		Amp	Amp	Efficiency 100%	Efficiency 75%	Efficiency 50%	Power Factor cosφ	Locked Current Is/In	Locked Torque Ts/Tn	Locked Torque Tm/Tn	Moment of inertia Kgm2	Weight Kg.
			230	400											
FA3-80 2-4	0,75	1400	230	400	2,97	1,72	82,5	82,7	81,0	0,77	7,00	2,4	2,4	0,003	12
FA3-90S-4	1,1	1420	230	400	4,25	2,45	84,1	84,3	82,6	0,775	7,50	2,4	2,4	0,004	16
FA3-90L-4	1,5	1420	230	400	5,68	3,28	85,3	85,4	83,8	0,778	8,00	2,4	2,4	0,054	20
FA3-100L1-4	2,2	1440	230	400	8,00	4,62	86,7	86,8	84,3	0,798	8,00	2,4	2,4	0,010	26
FA3-100L2-4	3	1440	230	400	10,80	6,20	87,7	87,8	86,0	0,801	8,00	2,4	2,4	0,013	30
FA3-112M-4	4	1450	400	690	7,97	4,60	88,6	88,8	88,3	0,821	7,50	2,4	2,4	0,020	38
FA3-132S-4	5,5	1450	400	690	10,80	6,24	89,6	89,7	89,0	0,825	7,50	2,3	2,4	0,035	46
FA3-132M-4	7,5	1450	400	690	14,40	8,32	90,4	90,6	90,1	0,834	7,50	2,3	2,4	0,047	54

TYPE	Power KW	RPM r/min	Voltage		Amp	Amp	Efficiency 100%	Efficiency 75%	Efficiency 50%	Power Factor cosφ	Locked Current Is/In	Locked Torque Ts/Tn	Locked Torque Tm/Tn	Moment of inertia Kgm2	Weight Kg.
			230	400											
FA3-90S-6	0,75	910	230	400	3,42	1,97	78,9	79,4	77,5	0,7	4,00	2,0	2,3	0,005	15
FA3-90L-6	1,1	910	230	400	4,80	2,78	81,0	81,3	80,2	0,71	4,00	2,0	2,3	0,008	20
FA3-100L-6	1,5	930	230	400	6,35	3,66	82,5	82,6	81,3	0,72	5,00	2,0	2,3	0,013	25
FA3-112M-6	2,2	940	230	400	8,98	5,20	84,3	85,0	83,2	0,73	5,00	2,0	2,3	0,020	30
FA3-132S-6	3	960	230	400	11,90	6,87	85,6	85,8	84,5	0,74	6,50	2,2	2,3	0,037	38,5
FA3-132M1-6	4	960	400	690	9,00	5,20	86,8	86,9	85,3	0,745	7,00	2,2	2,3	0,050	47,5
FA3-132M2-6	5,5	960	400	690	12,10	7,00	88,0	88,2	86,9	0,75	7,00	2,2	2,3	0,065	58

IMB3 - IE3 - ALUMINIUM

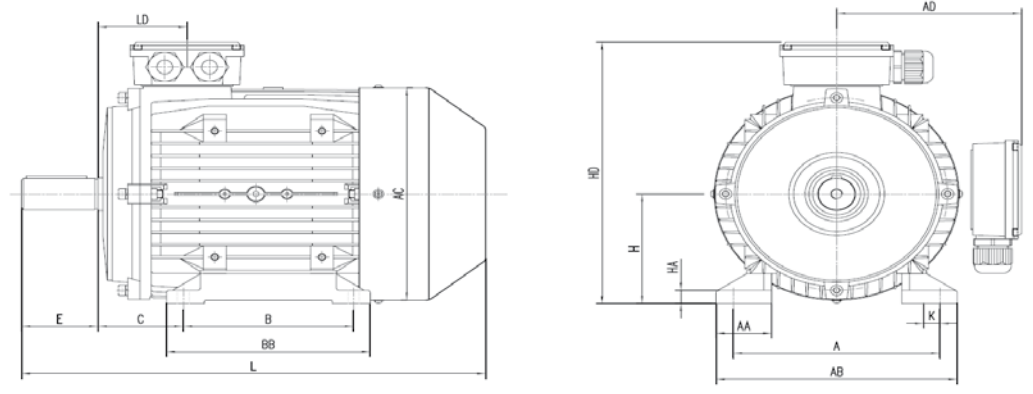

Frame Size	Pole	Dimensions					Dimensions								
		A	B	C	H	K	AA	AB	AC	AD	BB	HA	HD on top	LD	L
80	2-6	125	100	50	80° _{-0,5}	10	35	155	157	125	125	12	205	65	295
90S	2-6	140	100	56	90° _{-0,5}	10	37	180	177	138	155	14	228	66	355
90L	2-6	140	125	56	90° _{-0,5}	10	37	180	177	138	155	14	228	66	385
100L	2-6	160	140	63	100° _{-0,5}	12	45	200	205	150	180	14	250	85	440
112M	2-6	190	140	70	112° _{-0,5}	12	55	225	220	172	180	14	284	88	405
132S	2-8	216	140	89	132° _{-0,5}	12	58	255	256	192	176	14	324	94	455
132M	2-8	216	178	89	132° _{-0,5}	12	58	255	256	192	215	14	324	94	490

IMB5 - IE3 - ALUMINIUM

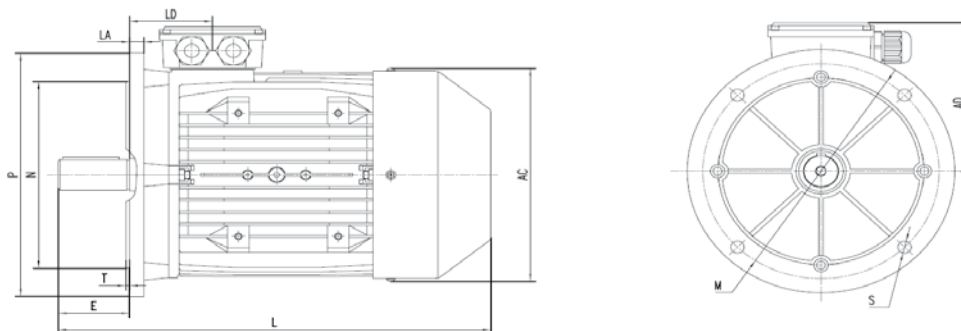

Frame Size	Pole	Dimensions					Dimensions				
		M	N	P	S	T	AC	AD	LA	LD	L
80	2-8	165	130	200	4-Φ12	4	157	125	12	65	295
90S	2-8	165	130	200	4-Φ12	4	177	138	12	66	355
90L	2-8	165	130	200	4-Φ12	4	177	138	12	66	385
100L	2-8	215	180	250	4-Φ15	4	205	150	14	85	440
112M	2-8	215	180	250	4-Φ15	4	220	172	14	88	405
132S	2-8	265	230	300	4-Φ15	4	256	192	15	94	455
132M	2-8	265	230	300	4-Φ15	4	256	192	15	94	490

IMB35 - IE3 - ALUMINIUM

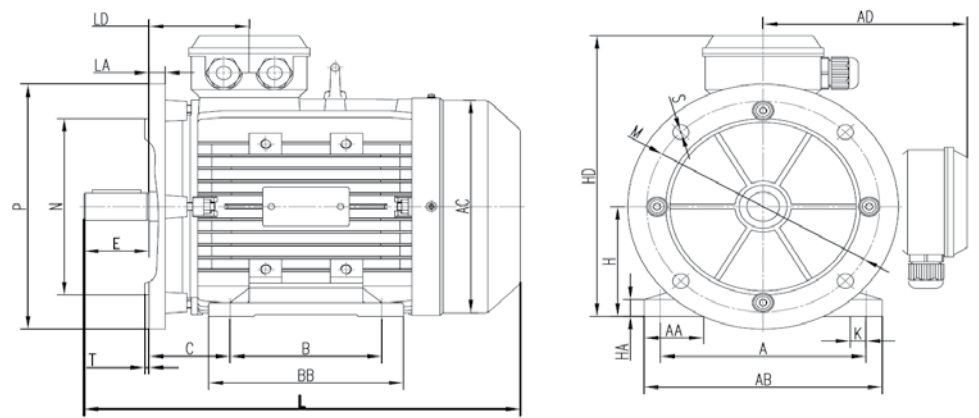

Frame Size	Pole	Dimensions											Dimensions									
		A	B	C	H	K	M	N	P	S	T	AA	AB	AC	AD	BB	HA	HD		LA	LD	L
																			Top	L&R		
80	2-6	125	100	50	80° _{-0,5}	10	165	130	200	4-Φ12	4	35	155	157	125	125	12	205	125	12	65	295
90S	2-6	140	100	56	90° _{-0,5}	10	165	130	200	4-Φ12	4	37	180	177	138	155	14	228	138	12	66	355
90L	2-6	140	125	56	90° _{-0,5}	10	165	130	200	4-Φ12	4	37	180	177	138	155	14	228	138	12	66	385
100L	2-6	160	140	63	100° _{-0,5}	12	215	180	250	4-Φ15	4	45	200	205	150	180	14	250	150	14	85	440
112M	2-6	190	140	70	112° _{-0,5}	12	215	180	250	4-Φ15	4	55	225	220	172	180	14	284	172	14	88	405
132S	2-6	216	140	89	132° _{-0,5}	12	265	230	300	4-Φ15	4	58	255	256	192	176	14	324	192	15	94	455
132M	2-6	216	178	89	132° _{-0,5}	12	265	230	300	4-Φ15	4	58	255	256	192	215	14	324	192	15	94	490

IMB14 - IE3 - ALUMINIUM

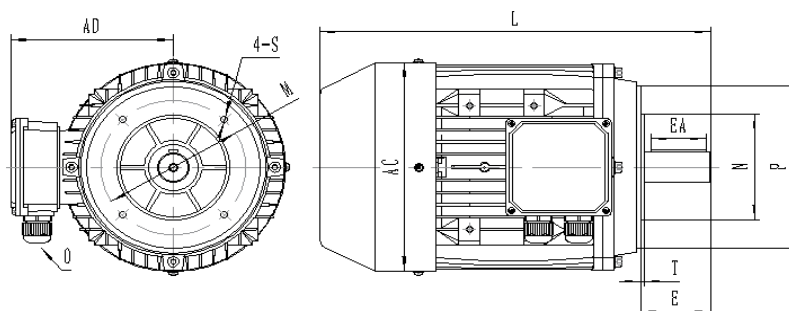

Frame Size	Pole	Dimensions					Dimensions			
		M	N	P	S	T	AC	AD	L	
80	2-8	100	80	120	4-M6	3	157	125	295	
90S	2-8	115	95	140	4-M8	3	177	138	355	
90L	2-8	115	95	140	4-M8	3	177	138	385	
100L	2-8	130	110	160	4-M8	3,5	205	150	440	
112M	2-8	130	110	160	4-M8	3,5	220	172	405	
132S	2-8	165	130	200	4-M10	4	256	192	455	
132M	2-8	165	130	200	4-M10	4	256	192	490	

IMB34 - IE3 - ALUMINIUM

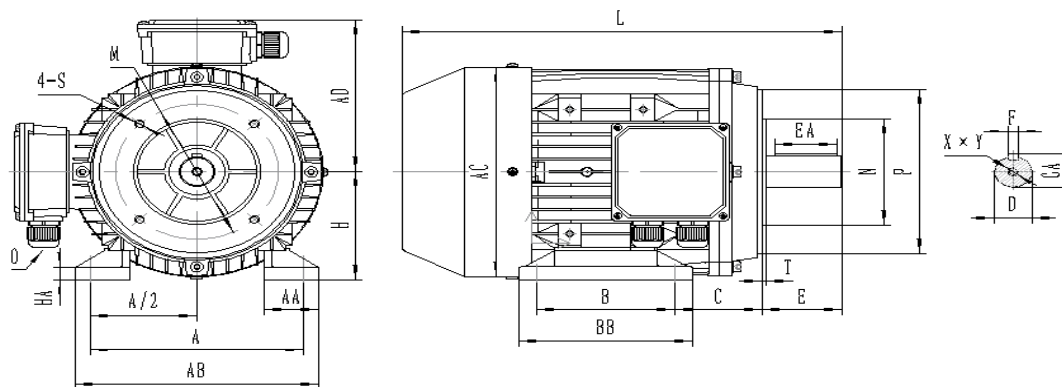

Frame Size	Pole	Dimensions											Dimensions											
		A	A/2	B	C	H	K	M	N	P	S	T	AA	AB	AC	AD	BB	HA	HD		L			
																						Top	L&R	
80	2-6	125	62,5	100	50	80° _{-0,5}	10	100	80	120	4-M6	3	35	155	157	125	125	12	205	125	295			
90S	2-6	140	70	100	56	90° _{-0,5}	10	115	95	140	4-M8	3	37	180	177	138	155	14	228	138	355			
90L	2-6	140	70	125	56	90° _{-0,5}	10	115	95	140	4-M8	3	37	180	177	138	155	14	228	138	385			
100L	2-6	160	80	140	63	100° _{-0,5}	12	130	110	160	4-M8	3,5	45	200	205	150	180	14	250	150	440			
112M	2-6	190	95	140	70	112° _{-0,5}	12	130	110	160	4-M8	3,5	55	225	220	172	180	14	284	172	405			
132S	2-6	216	108	140	89	132° _{-0,5}	12	165	130	200	4-M10	4	58	255	256	192	176	14	324	192	455			
132M	2-6	216	108	178	89	132° _{-0,5}	12	165	130	200	4-M10	4	58	255	256	192	215	14	324	192	490			

DIMENSIONE ALBERO - DIMENSION SHAFT

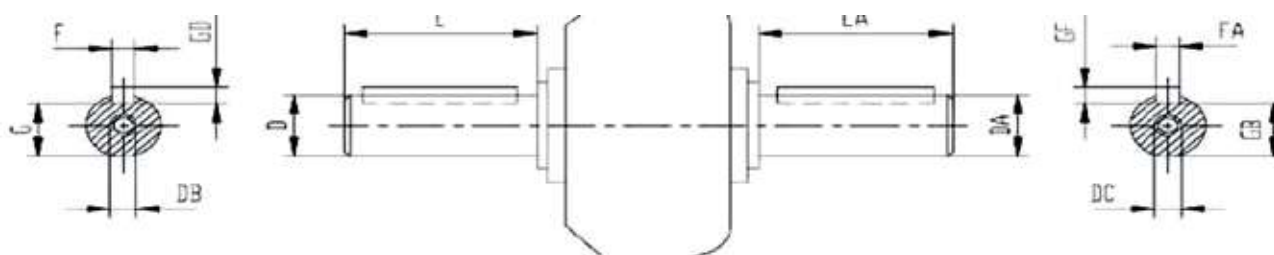

Frame	Pole	D	DA	E	EA	F	FA	G	GB	GD	GF	DB	DC
80	2-4-6	19 j6 ^(+0.009) _(-0.004)	19 j6 ^(+0.009) _(-0.004)	40	40	6	6	15:05	15:05	6	6	M6	M6
90S	2-4-6	24 j6 ^(+0.009) _(-0.004)	24 j6 ^(+0.009) _(-0.004)	50	50	8	8	20	20	7	7	M8	M8
90L	2-4-6												
100L	2-4-6	28 j6 ^(+0.009) _(-0.004)	28 j6 ^(+0.009) _(-0.004)	60	60			24	24			M10	M10
112M	2-4-6												
132S	2-4-6	38 k6 ^(+0.018) _(-0.002)	38 k6 ^(+0.018) _(-0.002)	80	80	10	10	33	33	8	8	M12	M12
132M	2-4-6												

IE3 CASTI RON HOUSING - TECHNICAL DATA

TYPE	Power KW	RPM r/min	Voltage		Amp	Amp	Efficiency 100%	Efficiency 75%	Efficiency 50%	Power Factor cosφ 100 %	Locked Current Is/In	Locked Torque Ts/Tn	Locked Torque Tm/Tn	Moment of inertia Kgm2	Weight Kg.
F3 160M-2	11	2940	400	690	20,0	11,6	91,2	91,3	88,5	0,87	8,10	2,00	2,30	0,051	125
F3 160MX-2	15	2940	400	690	27,1	15,7	91,9	92,0	89,1	0,87	8,10	2,00	2,30	0,064	136
F3 160L-2	18,5	2940	400	690	33,2	19,3	92,4	92,5	89,6	0,87	8,20	2,00	2,30	0,076	148
F3 180M-2	22	2950	400	690	38,9	22,6	92,7	92,8	89,9	0,88	8,20	2,00	2,30	0,117	189
F3 200L-2	30	2955	400	690	52,7	30,6	93,3	93,4	90,5	0,88	7,60	2,00	2,30	0,174	242
F3 200LX-2	37	2955	400	690	65,5	38,0	93,7	93,8	90,9	0,87	7,60	2,00	2,30	0,205	270
F3 225M-2	45	2960	400	690	77,6	45,0	94,0	94,1	91,2	0,89	7,70	2,00	2,30	0,302	328
F3 250M-2	55	2965	400	690	95,7	55,5	94,3	94,4	91,5	0,88	7,70	2,00	2,30	0,408	414
F3 280S-2	75	2975	400	690	129,9	75,3	94,7	94,8	91,9	0,88	7,10	1,80	2,30	0,799	541
F3 280M-2	90	2975	400	690	153,6	89,1	94,7	94,8	91,9	0,89	7,10	1,80	2,30	1,071	645
F3 315S-2	110	2980	400	690	183,3	106,2	95,2	95,3	92,3	0,91	7,10	1,80	2,30	2,031	900
F3 315M-2	132	2980	400	690	219,5	127,2	95,4	95,5	92,5	0,91	7,10	1,80	2,30	2,207	1025
F3 315L-2	160	2980	400	690	265,5	153,9	95,6	95,7	92,7	0,91	7,20	1,80	2,30	2,487	1160
F3 315LX-2	200	2980	400	690	331,1	192,0	95,8	95,9	92,9	0,91	7,20	1,80	2,20	2,907	1160
F3 355M-2	250	2980	400	690	413,9	240,0	95,8	95,9	92,9	0,91	7,20	1,60	2,20	3,812	1625
F3 355LX-2	315	2980	400	690	521,5	302,3	95,8	95,9	92,9	0,91	7,20	1,60	2,20	4,463	1750
F3 355LY-2	355	2980	400	690	587,8	340,7	95,8	95,9	92,9	0,91	7,20	1,60	2,20	4,463	1740

TYPE	Power KW	RPM r/min	Voltage		Amp	Amp	Efficiency 100%	Efficiency 75%	Efficiency 50%	Power Factor cosφ	Locked Current Is/In	Locked Torque Ts/Tn	Locked Torque Tm/Tn	Moment of inertia Kgm2	Weight Kg.
F3 160M-4	11	1470	400	690	21,4	12,4	91,4	91,5	88,7	0,81	7,70	2,20	2,30	0,107	138
F3 160L-4	15	1470	400	690	29,0	16,8	92,1	92,2	89,3	0,81	7,80	2,20	2,30	0,129	150
F3 180M-4	18,5	1470	400	690	35,2	20,4	92,6	92,7	89,8	0,82	7,80	2,00	2,30	0,190	186
F3 180L-4	22	1470	400	690	41,6	24,1	93,0	93,1	90,2	0,82	7,80	2,00	2,30	0,226	206
F3 200L-4	30	1475	400	690	55,1	31,9	93,6	93,7	90,8	0,84	7,30	2,00	2,30	0,361	269
F3 225S-4	37	1480	400	690	66,9	38,8	93,9	94,0	91,1	0,85	7,40	2,00	2,30	0,630	314
F3 225M-4	45	1480	400	690	81,1	47,0	94,2	94,3	91,4	0,85	7,40	2,00	2,30	0,738	356
F3 250M-4	55	1480	400	690	98,7	57,2	94,6	94,7	91,8	0,85	7,40	2,20	2,30	1,024	473
F3 280S-4	75	1490	400	690	134,1	77,7	95,0	95,1	92,2	0,85	6,90	2,00	2,30	2,083	620
F3 280M-4	90	1490	400	690	158,7	92,0	95,4	95,5	92,5	0,86	6,90	2,00	2,30	2,546	673
F3 315S-4	110	1485	400	690	193,5	112,2	95,4	95,5	92,5	0,86	7,00	2,00	2,20	3,490	875
F3 315M-4	132	1485	400	690	229,1	132,8	95,6	95,7	92,7	0,87	7,00	2,00	2,20	4,014	980
F3 315L-4	160	1485	400	690	277,1	160,6	95,8	95,9	92,9	0,87	7,10	2,00	2,20	5,236	1130
F3 315LX-4	200	1485	400	690	341,7	198,1	96,0	96,1	93,1	0,88	7,10	2,00	2,20	5,701	1185
F3 355M-4	250	1490	400	690	422,3	244,8	96,0	96,1	93,1	0,89	7,10	2,00	2,20	9,297	1660
F3 355LX-4	315	1490	400	690	532,2	308,5	96,0	96,1	93,1	0,89	7,10	2,00	2,20	10,286	1850
F3 355LY-4	355	1490	400	690	599,7	347,7	96,0	96,1	93,1	0,89	7,00	1,70	2,20	11,275	1865

TYPE	Power KW	RPM r/min	Voltage		Amp	Amp	Efficiency 100%	Efficiency 75%	Efficiency 50%	Power Factor cosφ	Locked Current Is/In	Locked Torque Ts/Tn	Locked Torque Tm/Tn	Moment of inertia Kgm2	Weight Kg.
F3 160M-6	7,5	970	400	690	16,6	9,6	89,1	89,2	86,4	0,73	7,00	2,00	2,10	0,117	122
F3 160L-6	11	970	400	690	23,8	13,8	90,3	90,4	87,6	0,74	7,20	2,00	2,10	0,177	144
F3 180L-6	15	975	400	690	30,1	17,4	91,2	91,3	88,5	0,79	7,30	2,00	2,10	0,316	201
F3 200L-6	18,5	980	400	690	36,9	21,4	91,7	91,8	88,9	0,79	7,30	2,00	2,10	0,468	243
F3 200LX-6	22	980	400	690	44,2	25,6	92,2	92,3	89,4	0,78	7,40	2,00	2,10	0,548	259
F3 225M-6	30	985	400	690	56,8	33,0	92,9	93,0	90,1	0,82	6,90	2,00	2,10	0,884	333
F3 250M-6	37	985	400	690	67,7	39,3	94,1	94,2	91,3	0,84	7,10	2,00	2,10	1,197	404
F3 280S-6	45	985	400	690	82,5	47,8	93,7	93,8	90,9	0,84	7,30	2,00	2,00	2,338	586
F3 280M-6	55	985	400	690	100,4	58,2	94,1	94,2	91,3	0,84	7,30	2,00	2,00	2,797	665
F3 315S-6	75	990	400	690	136,2	79,0	94,6	94,7	91,8	0,84	6,60	2,00	2,00	4,741	860
F3 315M-6	90	990	400	690	163,0	94,5	94,9	95,0	92,1	0,84	6,70	2,00	2,00	5,823	980
F3 315L-6	110	990	400	690	198,8	115,2	95,1	95,2	92,2	0,84	6,70	2,00	2,00	6,654	1050
F3 315LX-6	132	985	400	690	235,0	136,2	95,4	95,5	92,5	0,85	6,80	2,00	2,00	7,985	1100
F3 355M-6	160	990	400	690	284,2	164,8	95,6	95,7	92,7	0,85	6,80	1,80	2,00	10,386	1600
F3 355MY-6	200	990	400	690	354,5	205,5	95,8	95,9	92,9	0,85	6,80	1,80	2,00	12,413	1720
F3 355LX-6	250	990	400	690	438,0	253,9	95,8	95,9	92,9	0,86	6,80	1,80	2,00	13,933	1820

IMB3 - IE3 - CAST IRON

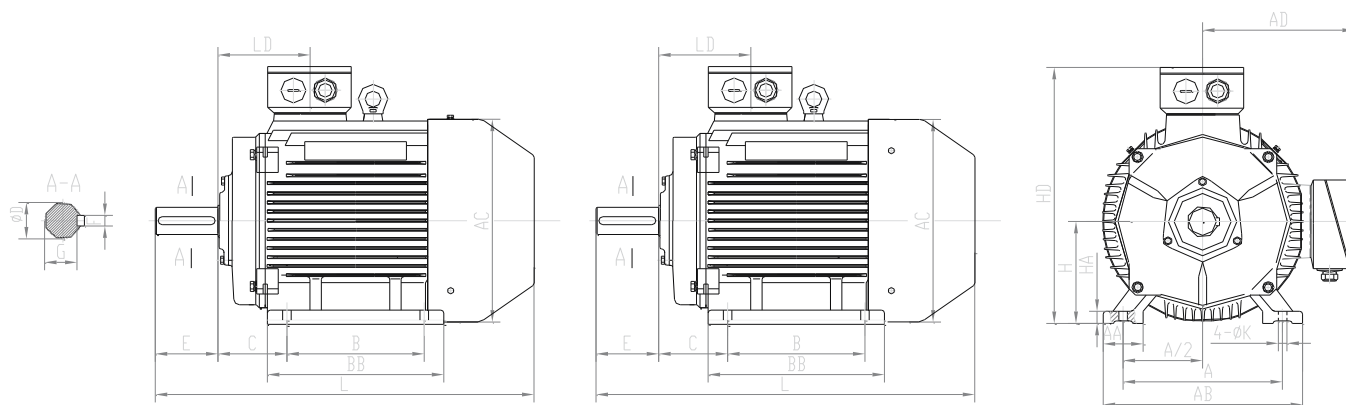

Frame Size	Pole	Dimensions							Dimensions								
		A	B	B1	B2	C	H	K	AA	AB	AC	AD	BB	HA	HD on top	LD	L
160M/L	2-6	254	210	254	-	108	160° _{-0,5}	15	65	315	315	265	305	20	411	146	627
180M	2-6	279	241	-	-	121	180° _{-0,5}	15	70	350	360	280	315	22	450	161	665
180L	4-6	279	279	-	-	121	180° _{-0,5}	15	70	350	360	280	350	22	450	161	705
200L	2	318	305	-	-	133	200° _{-0,5}	19	70	390	400	310	370	25	500	186	738
200L	4-6	318	305	-	-	133	200° _{-0,5}	19	70	390	400	310	370	25	500	186	758
225S	4-6	356	286	-	-	149	225° _{-0,5}	19	75	435	450	335	370	28	555	189	793
225M	2	356	311	-	-	149	225° _{-0,5}	19	75	435	450	335	395	28	555	189	775
	4-6	356	311	-	-	149	225° _{-0,5}	19	75	435	450	335	395	28	555	189	818
250M	2	406	349	-	-	168	250° _{-0,5}	24	80	485	490	375	445	30	625	207	870
	4-6	406	349	-	-	168	250° _{-0,5}	24	80	485	490	375	445	30	625	207	880
280S	2	457	368	-	-	190	280° _{-1,0}	24	85	545	550	405	490	35	670	215	950
	4-6	457	368	-	-	190	280° _{-1,0}	24	85	545	550	405	490	35	670	215	1020
280M	2	457	419	-	-	190	280° _{-1,0}	24	85	545	550	405	540	35	670	215	1000
	4-6	457	419	-	-	190	280° _{-1,0}	24	85	545	550	405	540	35	670	215	1070
315S	2	508	406	-	-	216	315° _{-1,0}	28	120	630	625	560	570	45	870	257	1180
	4-6	508	406	-	-	216	315° _{-1,0}	28	120	630	625	560	570	45	870	257	1185
315M/L	2	508	457	508	-	216	315° _{-1,0}	28	120	630	625	560	680	45	870	257	1279
	4-6	508	457	508	-	216	315° _{-1,0}	28	120	630	625	560	680	45	870	257	1323
355ML	2	610	500	560	630	254	355° _{-1,0}	28	120	730	710	615	750	52	956	284	1526
	4-6	610	500	560	630	254	355° _{-1,0}	28	120	730	710	615	750	52	956	284	1556

IMB5 - IE3 - CAST IRON

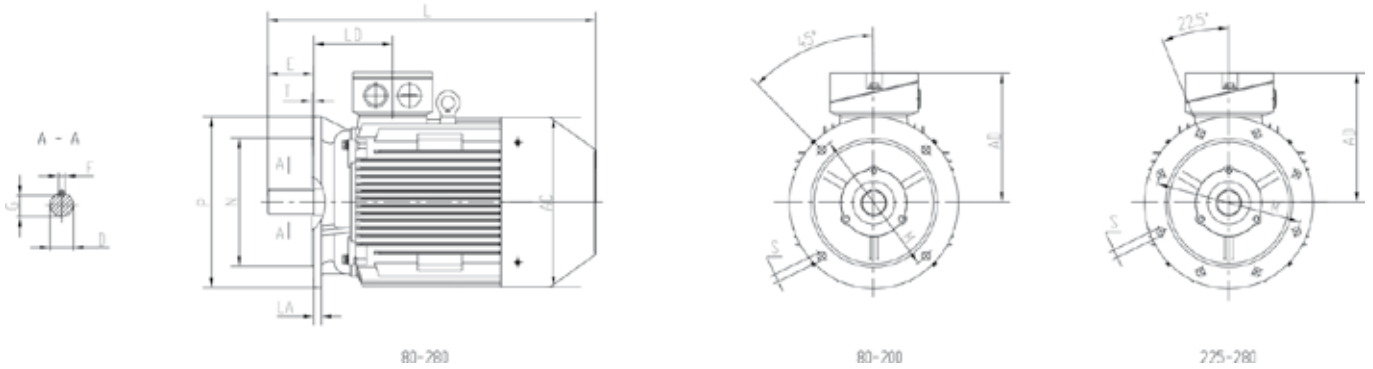

Frame Size	Pole	Dimensions					Dimensions				
		M	N	P	S	T	AC	AD	LA	LD	L
160M/L	2-6	300	250	350	4-Φ19	5	315	265	15	146	627
180M	2-6	300	250	350	4-Φ19	5	360	280	15	161	665
180L	4-6	300	250	350	4-Φ19	5	360	280	15	161	705
200L	2	350	300	400	4-Φ19	5	400	310	17	186	738
200L	4-6	350	300	400	4-Φ19	5	400	310	17	186	758
225S	4-6	400	350	450	8-Φ19	5	450	330	20	189	793
225M	2	400	350	450	8-Φ19	5	450	330	20	189	775
	4-6	400	350	450	8-Φ19	5	450	330	20	189	818
250M	2	500	450	550	8-Φ19	5	490	375	22	207	870
	4-6	500	450	550	8-Φ19	5	490	375	22	207	880
280S	2	500	450	550	8-Φ19	5	550	405	22	215	950
	4-6	500	450	550	8-Φ19	5	550	405	22	215	1020
280M	2	500	450	550	8-Φ19	5	550	405	22	215	1000
	4-6	500	450	550	8-Φ19	5	550	405	22	215	1070

IMB3/B5 - IE3 - CAST IRON

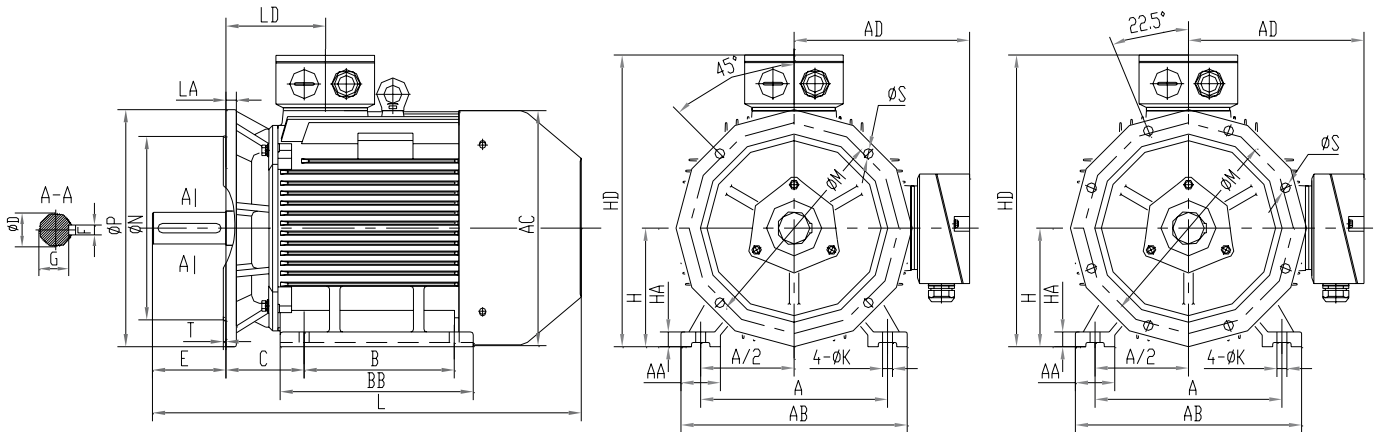

Frame Size	Pole	Dimensions													Dimensions										
		A	B	B1	B2	C	H	K	M	N	P	S	T	AA	AB	AC	AD	BB	HA	HB	HD		LA	LD	L
																					Top	L&R			
160M/L	2-6	254	210	254		108	160° _{-0.5}	15	300	250	350	4-Φ19	5	65	315	315	265	305	20	81	411	385	15	146	627
180M	2-6	279	241	-		121	180° _{-0.5}	15	300	250	350	4-Φ19	5	70	350	360	280	315	22	105	450	420	15	161	665
180L	4-6	279	279	-		121	180° _{-0.5}	15	300	250	350	4-Φ19	5	70	350	360	280	350	22	105	450	420	15	161	705
200L	2	318	305	-		133	200° _{-0.5}	19	350	300	400	4-Φ19	5	70	390	400	310	370	25	85	500	475	17	186	738
200L	4-6	318	305	-		133	200° _{-0.5}	19	350	300	400	4-Φ19	5	70	390	400	310	370	25	85	500	475	17	186	758
225S	4-6	356	286	-		149	225° _{-0.5}	19	400	350	450	8-Φ19	5	75	435	450	335	370	28	110	555	535	20	189	793
225M	2	356	311	-		149	225° _{-0.5}	19	400	350	450	8-Φ19	5	75	435	450	335	395	28	110	555	535	20	189	775
	4-6	356	311	-		149	225° _{-0.5}	19	400	350	450	8-Φ19	5	75	435	450	335	395	28	110	555	535	20	189	818
250M	2	406	349	-		168	250° _{-0.5}	24	500	450	550	8-Φ19	5	80	485	490	375	445	30	110	625	570	22	207	870
	4-6	406	349	-		168	250° _{-0.5}	24	500	450	550	8-Φ19	5	80	485	490	375	445	30	120	625	570	22	207	880
280S	2	457	368	-		190	280° _{-1.0}	24	500	450	550	8-Φ19	5	85	545	550	405	490	35	142	670	660	22	215	950
	4-6	457	368	-		190	280° _{-1.0}	24	500	450	550	8-Φ19	5	85	545	550	405	490	35	142	670	660	22	215	1020
280M	2	457	419	-		190	280° _{-1.0}	24	500	450	550	8-Φ19	5	85	545	550	405	540	35	142	670	660	22	215	1000
	4-6	457	419	-		190	280° _{-1.0}	24	500	450	550	8-Φ19	5	85	545	550	405	540	35	142	670	660	22	215	1070
315S	2	508	406	-		216	315° _{-1.0}	28	600	550	660	8-Φ24	6	120	630	625	530	570	45	110	870	750	22	257	1108
	4-6	508	406	-		216	315° _{-1.0}	28	600	550	660	8-Φ24	6	120	630	625	530	570	45	110	870	750	22	257	1185
315M/L	2	508	457	508		216	315° _{-1.0}	28	600	550	660	8-Φ24	6	120	630	625	530	680	45	110	870	750	22	257	1279
	4-6	508	457	508		216	315° _{-1.0}	28	600	550	660	8-Φ24	6	120	630	625	530	680	45	110	870	750	22	257	1323
355ML	2	610	500	560	630	254	355° _{-1.0}	28	740	680	800	8-Φ24	6	120	730	710	615	750	52	125	956	830	25	284	1526
	4-6	610	500	560	630	254	355° _{-1.0}	28	740	680	800	8-Φ24	6	120	730	710	615	750	52	125	956	830	25	284	1556

IMV1 - IE3 - CAST IRON

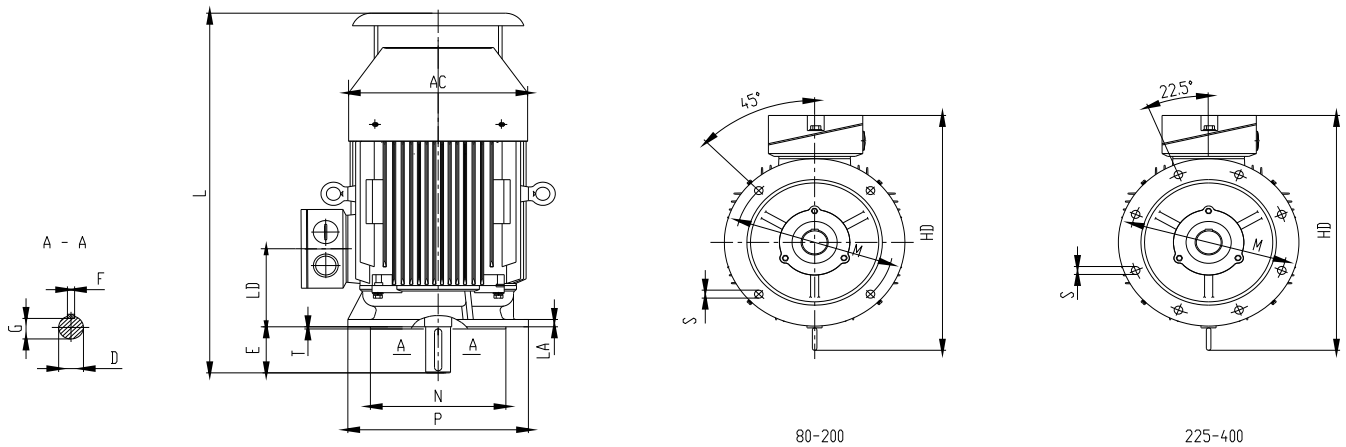

Frame Size	Pole	Dimensions				Dimensions					
		M	N	P	S	T	AC	HD	LA	LD	L
160M/L	2-6	300	250	350	4- Φ 19	5	315	476	15	146	680
180M	2-6	300	250	350	4- Φ 19	5	360	510	15	161	710
180L	4-6	300	250	350	4- Φ 19	5	360	510	15	161	770
200L	2	350	300	400	4- Φ 19	5	400	565	17	186	818
200L	4-6	350	300	400	4- Φ 19	5	400	565	17	186	838
225S	4-6	400	350	450	8- Φ 19	5	450	620	20	189	887
225M	2	400	350	450	8- Φ 19	5	450	620	20	189	873
	4-6	400	350	450	8- Φ 19	5	450	620	20	189	942
250M	2	500	450	550	8- Φ 19	5	490	695	22	207	971
	4-6	500	450	550	8- Φ 19	5	490	695	22	207	1005
280S	2	500	450	550	8- Φ 19	5	550	755	22	215	1071
	4-6	500	450	550	8- Φ 19	5	550	755	22	215	1138
280M	2	500	450	550	8- Φ 19	5	550	755	22	215	1116
	4-6	500	450	550	8- Φ 19	5	550	755	22	215	1193
315S	2	600	550	660	8- Φ 24	6	625	985	22	257	1329
	4-6	600	550	660	8- Φ 24	6	625	985	22	257	1345
315M/L	2	600	550	660	8- Φ 24	6	625	985	22	257	1453
	4-6	600	550	660	8- Φ 24	6	625	985	22	257	1483
355ML	2	740	680	800	8- Φ 24	6	710	1001	25	284	1665
	4-6	740	680	800	8- Φ 24	6	710	1001	25	284	1700

DIMENSIONE ALBERO - SHAFT DIMENSION

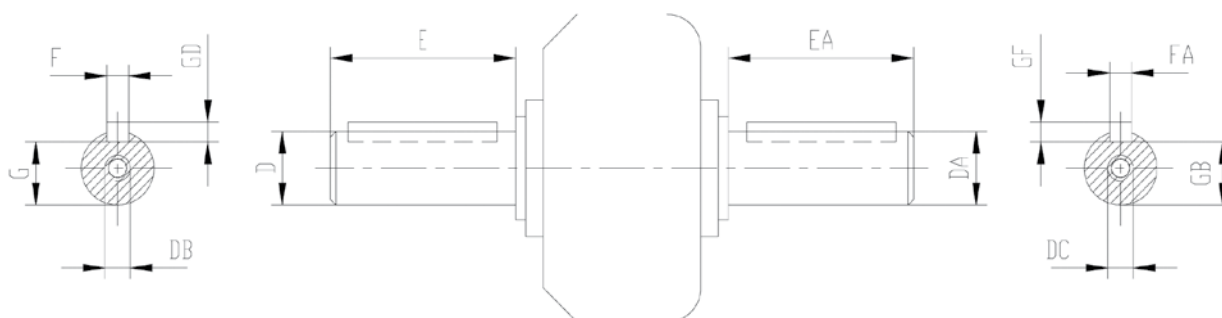

Frame	Pole	D	*DA	E	*EA	F	*FA	G	*GB	GD	*GF	DB-DC
160M	2-4-6	42 k6	42 k6	110	110	12	12	37	37			M16x36
160L												
180M	2-4-6	48 k6	48 k6			14	14	42,5	42,5	9	9	
180L												
200L	2-4-6	55 m6	55 m6	140	140	16	16	49	49	10	10	M20x42
225S	4-6	60 m6	55 m6	110	110	18	16	53	49	11	10	
225M	2	55 m6	48 k6	140	140	16	14	49	45,5	10	9	
	4-6	60 m6	55 m6					53	49	11	10	
250M	2	60 m6		140	140	18	16	53	49	11	10	
	4-6	65 m6						58	49			
280S	2	65 m6	65 m6	140	140	20	18	58	49	11	10	
	4-6	75 m6						67,5	53	12	11	
280M	2	65 m6	55 m6	140	140	18	16	58	49	11	10	
	4-6	75 m6	65 m6					67,5	53	12	11	
315S	2	65 m6	65 m6	140	140	18	18	58	58	11	11	
	4-6	80 m6	80 m6	170	170	22	22	71	71	14	14	
315ML	2	65 m6	65 m6	140	140	18	18	58	58	11	11	
	4-6	80 m6	80 m6	170	170	22	22	71	71	14	14	
355ML	2	75 m6	75 m6	140	140	20	20	67,5	67,5	12	12	M24x50
	4-6	100m6	100m6	210	210	28	28	90	90	14	14	

*Dimensions for NDE shaft, when it's requested, shall be confirmed with order agreement.

BEARINGS

Frame	D.E.	D.E.	D.E.	N.D.E.	N.D.E.	N.D.E.
	2 pole	4 pole	6 pole	2 pole	4 pole	6 pole
Aluminium						
FA3 80	6204 2RS C3	6204 2RS C3	6204 2RS C3	6204 2RS C3	6204 2RS C3	6204 2RS C3
FA3 90	6205 2RS C3	6205 2RS C3	6205 2RS C3	6205 2RS C3	6205 2RS C3	6205 2RS C3
FA3 100	6206 2RS C3	6206 2RS C3	6206 2RS C3	6206 2RS C3	6206 2RS C3	6206 2RS C3
FA3 112	6306 2RS C3	6306 2RS C3	6306 2RS C3	6206 2RS C3	6206 2RS C3	6206 2RS C3
FA3 132	6308 2RS C3	6308 2RS C3	6308 2RS C3	6208 2RS C3	6208 2RS C3	6208 2RS C3

Cast Iron						
F3 160	6309 ZZ C3	6309 ZZ C3	6309 ZZ C3	6309 ZZ C3	6309 ZZ C3	6309 ZZ C3
F3 180	6311 ZZ C3	6311 ZZ C3	6311 ZZ C3	6311 ZZ C3	6311 ZZ C3	6311 ZZ C3
F3 200	6312 ZZ C3	6312 ZZ C3	6312 ZZ C3	6312 ZZ C3	6312 ZZ C3	6312 ZZ C3
F3 225	6313 ZZ C3	6313 ZZ C3	6313 ZZ C3	6313 ZZ C3	6313 ZZ C3	6313 ZZ C3
F3 250	6314 C3	6314 C3	6314 C3	6314 C3	6314 C3	6314 C3
F3 280	6314 C3	6317 C3	6317 C3	6314 C3	6317 C3	6317 C3
F3 315	6317 C3	6319 C3	6319 C3	6317 C3	6319 C3	6319 C3
F3 355	6317 C3	6322 C3	6322 C3	6317 C3	6320 C3	6320 C3
F3 355	6317 C3	6322 C3	6322 C3	6317 C3	6320 C3	6320 C3

CABLE GLANDS

Aluminium	Ø Thread	Exit hole (mm)
FA3 80	M25x1,5	11...17
FA3 90	M25x1,5	11...17
FA3 100	M25x1,5	11...17
FA3 112	M25x1,5	11...17
FA3 132	M25x1,5	11...17
FA3 160	M40x1,5	19...28
Cast Iron		
F3 160	M40x1,5	19...28
F3 180	M40x1,5	19...28
F3 200	M50x1,5	26...35
F3 225	M50x1,5	26...35
F3 250	M63x1,5	32...48
F3 280	M63x1,5	32...48
F3 315	M63x1,5	32...48
F3 355	M72x2	///

All data listed in the tables are indicative and not binding. The guaranteed values are upon request. Felm srl reserves the right to change the project, the technical characteristics and dimensions at any time without previous notice.

PERMISSIBLE AXIAL LOADS

The following table gives the permissible axial forces in Newton, assuming zero radial force. In this case motor should be ordered with standard ball bearings. In case of higher axial force than given in the table an angular contact bearing should be ordered. The values are based on normal conditions at 50Hz. and calculated at 20000 working hour for two pole motors and 40000 hours for 4, 6 and 8 pole motors. At 60Hz. the values must be reduced by 10%. For two-speed motors the values have to be based at the higher speed. Fpressure (D.E.) is calculated for a fixed bearing at the Drive End.

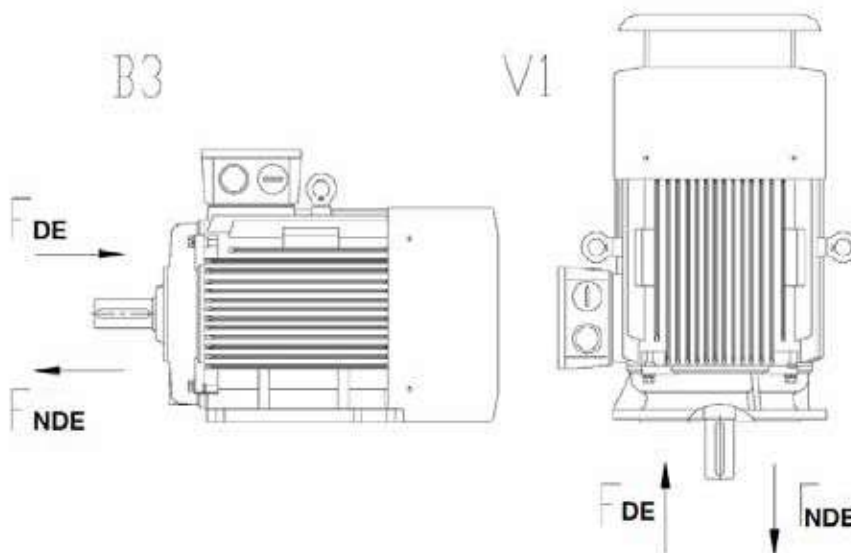

Frame Size	pole	Maximum axial force (FA)			
		B3 FDE	B3 FNDE	V1 FDE	V1 FNDE
80	2	380	380	400	360
	4	470	470	490	450
	6	590	590	620	560
	8	620	620	650	595
90	2	440	440	470	410
	4	550	550	600	510
	6	620	620	680	460
100	2	610	610	670	570
	4	750	750	840	710
	6	880	880	0970	820
112	2	1220	1220	1300	1170
	4	1440	1440	1520	1370
	6	1650	1650	1740	1580
132	2	1500	1500	1620	1430
	4	1780	1780	1970	1610
	6	1820	1820	2000	1660
160	2	1650	1650	1950	1350
	4	2100	2100	2470	1720
	6	2450	2450	2800	2050
180	2	2100	2100	2450	1720
	4	2600	2600	3200	2000
	6	2900	2900	3510	2280
	8	3170	3170	3780	2550

Frame Size	pole	Maximum axial force (FA)			
		B3 FDE	B3 FNDE	V1 FDE	V1 FNDE
200	2	2400	2400	2940	1840
	4	3120	3120	3850	2390
	6	3480	3480	4350	2610
	8	3950	3950	4810	3090
225	2	2720	2720	3420	2020
	4	2480	3480	4370	2590
	6	2890	3890	5040	2820
250	2	3100	3100	3940	2260
	4	3900	3900	5000	2800
	6	4450	4450	5570	3230
280	2	5300	3100	6500	2100
	4	6300	4400	7800	3000
	6	6700	4300	7900	2900
315	2	7100	5020	9100	3520
	4	5900	3800	8000	2000
	6	7100	5100	10700	3150
355*	2	7600	5800	11800	3500
	4	8100	6300	12500	4400
	6	6100	1850	14000	800
	8	9800	3900	18300	2500*
	6	10500	4700	20700	3500*
	8	12500	6000	21500	3600*

*= Data calculated with roll bearings

PERMISSIBLE RADIAL LOADS

The following table give the permissible radial forces in Newton, assuming zero axial force and standard ball bearings. In case of higher radial force than give in the table an enforced bearing should be ordered. The values are based on normal conditions at 50 Hz and calculated at 20 000 working hours for the two pole motors and 40 000 working hours for 4,6 and 8 poles. For 60 Hz the value must be reduced by 10%. For two speed motors, the values have to be based at the higher speed.

Pulley diameter:

when the desired bearing life has been determined, the minimum pulley diameter can be calculated with the following formula:

$$D_{min} = \frac{1.9 \times 10^7 \times k \times P_N}{n_N \times F_R}$$

D_{min} = diameter of the pulley (mm)

P = power of the motor (kW)

n = motor rated speed (r/min)

k = belt tension factor, $k=2.5$ for V-belt

$F_{R(x)}$ = permissible radial force (N)

$$F_R = F_{X0} - \frac{X}{E} (F_{X0} - F_{Xmax})$$

E = the length of the shaft diameter (mm.) in basic version

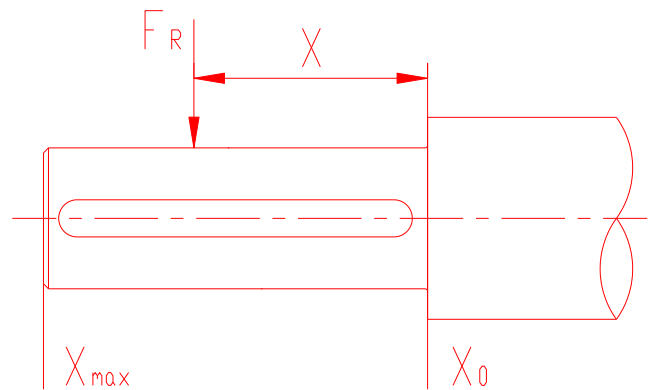

Frame Size	pole	Maximum radial force (FA)		
		X_0	$X_{1/2}$	X_{max}
80	2	670	610	550
	4	730	650	590
	6	830	750	680
	8	920	820	750
90	2	740	660	590
	4	800	710	630
	6	920	810	730
	8	1010	890	800
100	2	1030	920	820
	4	1110	990	890
	6	1270	1130	1020
	8	1400	1240	1120
112	2	1490	1330	1200
	4	1600	1430	1290
	6	1840	1640	1480
	8	2020	1800	1630
132	2	2160	1900	1690
	4	2330	2040	1820
	6	2670	2340	2080
	8	2940	2570	2290
160	2	2800	2440	2170
	4	3000	2630	2330
	6	3440	3010	2670
	8	3850	3410	3060
180	2	3930	3500	3150
	4	4240	3770	3390
	6	4890	4390	3980
	8	5380	4830	4380

Frame Size	pole	Maximum radial force (FA)		
		X_0	$X_{1/2}$	X_{max}
200	2	4480	4050	3700
	4	4820	4360	3980
	6	5520	5000	4560
	8	6080	5500	5020
225	2	5000	4540	4160
	4	5360	4720	4210
	6	6180	5480	4920
	8	6750	5940	5310
250	2	5680	5100	4620
	4	6120	5490	4980
	6	7000	6280	5700
	8	7710	6920	6270
280	2	5620	5080	4640
	4	7790	7050	6430
	6	8920	8060	7360
	8	9820	8880	8100
315	2	7370	6840	6390
	4	9150	8370	7720
	6	10480	9590	8830
	8	11530	10550	9720
355*	2	16330	15390	8730
	4	28300	25860	14290
	6	32400	29600	16350
	8	35660	32580	18000



CONTATCS

Head Quarter

FELM srl

Via Morandi (Industrial Area)

20010 Inveruno (Mi) Italy

Tel. +39 02 97 289 454

Tel. +39 02 97 288 320

Fax +39 02 97 289 923

E-mail home@felm.it



FELM Office Germany

Heinrich-Busold-Strasse 47

D-61169 Fridberg (Hessen), Germany

Tel. (Off.) +49 6331 721606

Mobile +49 172 6729011

E-mail Jayant@jk-conrep.de

FELM Office China

Room 1002, Building 3#, No.139 Rd. SongShan
Jianye, Nanjing, Jiangsu, China

Te. +86 150 778 29 999

Fax +86 25 87 797 622

E-mail lidongming1974@vip.sina.com

FELM Office Middle East

Al Saalam Street, Al Darwish Building (NBAD
building)

office no. 1403 Abu Dhabi (United Arab Emirates)

P.O. Box 45223

Office Ph. + 971-2-6710330

Office Fax + 971-2-6710255

mobile +971 50 4442093

WORLD WIDE SERVICE

Mobile +39 355 69 53 804

E-mail service@felm.it



Certificate
EAC - CUTR
EurAseC
(Russian Market)



HIGH EFFICIENCY ELECTRIC MOTORS

IE4



GENERAL CHARACTERISTICS

Design, manufacture and testing of squirrel cage induction motors made by FELM® are in according to IEC standard, Felm supplies high quality cast iron motors with a high performance and a professional flexibility to meet customer request. Motors are widely used in various industries sector like mining, power, water, cement, wind, ect.

Compact Motors - Technical details:

Efficiency level: Premium IE4 Motors < 0,12 kW - > 1000 kW High efficiency level	
Number of Poles: 2 up to 8	
Frequency: 50 Hz.	(Optional: 60 Hz.)
Voltage: 400 V.	(Optional: other rated voltages)
Frames: 71 up to 560	
Cast iron frame	
Cooling system: IC411	(Options: IC416 Inverter use rated 1:10)
Die cast Aluminum Rotor	
Color: RAL 5010 (Blue)	(Options: others type of color)
Shaft sealing: O' Ring	
VPI Insulation System	
Insulation class F (class B temperature rise)	(Options: Class H)
Protection degree: IP55	(Options: IP56 - IP6 5- IP66)
Mounting: B3	(Options: B35 - V1 – B14)
Painting plan:	(Options: Marine - Chemical - Munsell)
Internal epoxy coating (tropicalized)	
Sintered drain plug	
Terminal block on top	
Shaft Material: C45	
Double grounding (1 inside terminal box + 2 on the frame)	
Grease Caltex SRI-2 or SKF LGHP2	(Different types recommended by Felm)
Re-greasing system for frames 315 up to 560	
Options:	
Space Heaters connected in a separate auxiliary terminal box	
Configuration for any type of Encoder	
Special shaft material	
Automatic lubrication on board	
DC or AC Brake	

Motors comply with IE4 performance level, defined by the IEC 60034-30-1 standard.

Which will be launched after the 2023

IEC 60034 specifies efficiency classes for single-speed electric motors which are de-rated according to IEC 60034-1 or IEC 60079-0 and for operations on a sinusoidal voltage supply as follow:

Motors which has a rated power P_N from 0,12 kW to 1 000 kW;

- rated voltage U_N above 50 V up to 1 kV;
 - number of poles 2, 4, 6 or 8;
 - those are capable of continuous operation at their own de-rated power with a temperature rise within a specified insulation temperature class;
- motors covered by this standard are de-rated for duty type S1 (continuous duty).
- those are marked with any kind of ambient temperature within the range of $-20\text{ }^{\circ}\text{C}$ to $+60\text{ }^{\circ}\text{C}$;



IEC 60034-30-1:2014

Nominal efficiency limits (%) for 50 Hz IE4

P_N kW	Number of poles/synchronous speed min ⁻¹			
	2/3000	4/1500	6/1000	8/750
0,12	66,5	69,8	64,9	62,3
0,18	70,8	74,7	70,1	67,2
0,20	71,9	75,8	71,4	68,4
0,25	74,3	77,9	74,1	70,8
0,37	78,1	81,1	78,0	74,3
0,40	78,9	81,7	78,7	74,9
0,55	81,5	83,9	80,9	77,0
0,75	83,5	85,7	82,7	78,4
1,1	85,2	87,2	84,5	80,8
1,5	86,5	88,2	85,9	82,6
2,2	88,0	89,5	87,4	84,5
3	89,1	90,4	88,6	85,9
4	90,0	91,1	89,5	87,1
5,5	90,9	91,9	90,5	88,3
7,5	91,7	92,6	91,3	89,3
11	92,6	93,3	92,3	90,4
15	93,3	93,9	92,9	91,2
18,5	93,7	94,2	93,4	91,7
22	94,0	94,5	93,7	92,1
30	94,5	94,9	94,2	92,7
37	94,8	95,2	94,5	93,1
45	95,0	95,4	94,8	93,4
55	95,3	95,7	95,1	93,7
75	95,6	96,0	95,4	94,2
90	95,8	96,1	95,6	94,4
110	96,0	96,3	95,8	94,7
132	96,2	96,4	96,0	94,9
160	96,3	96,6	96,2	95,1
200	96,5	96,7	96,3	95,4
250	96,5	96,7	96,5	95,4
315 up to 1 000	96,5	96,7	96,6	95,4

Motor Type	Rated Power		Rated Speed	Efficiency	Power Factor	Current			Torque		
						FULL Load 400V	FULL Load 690V	Locked Rotor	Full Load	Locked Rotor	Pull Out
	KW	(HP)	RPM	%	A	A	%FLC	Kg-m	%FLT	%FLT	
IE4-160 L2	11	15	2960	92,6	0,89	19,3	11,2	8,4	4	3,1	3,7
IE4-160 LX2	15	20	2940	93,3	0,88	26,5	15,4	7,8	5	2,6	2,9
IE4-160 LY2	18,5	25	2940	93,7	0,88	32,4	18,8	7,6	6	2,3	3,0
IE4-160 L4	11	15	1475	93,3	0,85	20,0	11,6	7,8	7	2,5	3,1
IE4-160 LX4	15	20	1475	93,9	0,81	28,5	16,5	7,8	10	2,9	3,3
IE4-160 LX6	11	15	975	92,3	0,75	22,9	13,3	6,7	11	2,1	2,7
IE4-180 M2	22	30	2950	94,0	0,88	38,3	22,2	7,9	7	2,7	3,6
IE4-180 M4	18,5	25	1475	94,2	0,82	34,8	20,2	7,9	12	2,5	3,6
IE4-180 L4	22	30	1475	94,5	0,80	42,3	24,5	7,8	14	2,5	3,8
IE4-180 L6	15	20	985	92,9	0,77	30,5	17,7	6,3	15	2,1	3,1
IE4-200 L2	30	40	2960	94,5	0,87	52,7	30,5	7,4	10	2,4	3,4
IE4-200 LX2	37	50	2960	94,8	0,87	65,1	37,7	7,6	12	2,4	3,3
IE4-200 L4	30	40	1480	94,9	0,81	56,1	32,5	8,8	19	2,7	3,5
IE4-200 L6	18,5	25	985	93,4	0,77	37,1	21,5	7,3	18	2,4	3,1
IE4-200 LX6	22	30	985	93,7	0,78	43,6	25,3	7,5	21	2,4	3,1
IE4-225 M2	45	60	2950	95,0	0,88	77,8	45,1	7,8	15	2,3	3,4
IE4-225 S4	37	50	1485	95,2	0,68	82,4	47,8	6,6	24	3,2	3,9
IE4-225 M4	45	60	1485	95,4	0,84	81,1	47,0	7,8	29	3,2	3,7
IE4-225 M6	30	40	985	94,2	0,82	56,2	32,6	6,8	29	2,6	3,1
IE4-250 M2	55	75	2970	95,3	0,89	93,5	54,2	7,1	18	2,0	3,3
IE4-250 M4	55	75	1485	95,7	0,86	96,9	56,2	7,7	35	2,5	3,6
IE4-250 M6	37	50	985	94,5	0,84	67,7	39,2	7,3	36	2,3	3,4
IE4-280 S2	75	100	2975	95,6	0,88	128	74,3	6,3	24	2,0	2,9
IE4-280 M2	90	120	2980	95,8	0,88	154	89,3	7,7	29	2,5	3,7
IE4-280 S4	75	100	1490	96,0	0,85	133	77,3	7,3	48	2,6	3,2
IE4-280 M4	90	120	1490	96,1	0,86	157	91,2	7,6	58	2,6	3,4
IE4-280 S6	45	60	990	94,8	0,84	81	47,1	7,4	43	2,7	3,5
IE4-280 M6	55	75	990	95,1	0,84	99	57,7	8,0	53	3,2	4,0
IE4-315 S2	110	145	2970	96,0	0,90	183	106	7,4	35	2,0	3,2
IE4-315 M2	132	175	2975	96,2	0,91	219	127	7,0	42	1,8	2,9
IE4-315 L2	160	215	2970	96,3	0,90	267	155	6,6	51	1,8	3,0
IE4-315 LX2	200	270	2965	96,5	0,91	330	191	6,4	64	1,9	3,0
IE4-315 S4	110	145	1490	96,3	0,85	193	112	7,8	71	3,0	3,9
IE4-315 M4	132	175	1490	96,4	0,88	225	130	8,0	85	2,9	4,0
IE4-315 L4	160	215	1490	96,6	0,86	277	160	7,9	103	3,0	4,1
IE4-315 LX4	200	270	1490	96,7	0,89	337	196	6,1	128	2,7	3,3
IE4-315 S6	75	100	990	95,4	0,83	137	80	7,4	72	2,5	3,4
IE4-315 M6	90	120	990	95,6	0,83	163	95	7,6	87	2,7	3,6
IE4-315 L6	110	145	990	95,8	0,84	198	115	7,7	106	2,8	3,7
IE4-315 LX6	132	175	990	96,0	0,84	237	137	7,8	127	2,8	3,7
IE4-355 M2	250	335	2980	96,5	0,90	414	240	7,7	80	2,0	3,5
IE4-355 L2	280	375	2975	96,5	0,91	461	267	6,9	90	1,7	3,1
IE4-355 LX2	315	420	2980	96,5	0,92	512	297	8,2	101	2,1	3,8
IE4-355 LY2	355	475	2975	96,5	0,91	584	338	7,2	114	1,9	3,4
IE4-355 M4	250	335	1490	96,7	0,89	420	244	7,3	160	2,3	3,5
IE4-355 L4	280	375	1490	96,7	0,89	468	271	6,5	180	2,0	3,1
IE4-355 LX4	315	420	1490	96,7	0,88	533	309	7,0	202	2,3	3,4
IE4-355 LY4	355	475	1490	96,7	0,89	593	344	7,2	228	2,2	3,3
IE4-355 M6	160	215	990	96,2	0,85	283	164	7,0	154	1,9	3,3
IE4-355 MX6	185	250	990	96,2	0,85	328	190	7,3	178	2,0	3,4
IE4-355 MY6	200	270	990	96,3	0,85	353	205	7,1	193	1,9	3,3
IE4-355 L6	220	300	990	96,3	0,85	388	225	7,4	212	2,0	3,5
IE4-355 LX6	250	335	990	96,5	0,87	431	250	6,7	241	1,8	2,9

Save the Date

Efficiency Level Next Steps

Dal 1° luglio 2021:

- i motori trifase (D.O.L. e azionati da VFD) da $0,75 \text{ kW} \leq P \leq 1.000 \text{ kW}$ a 2, 4, 6, 8 poli, ad esclusione dei motori Ex-eb devono essere **IE3**.
- i motori trifase da $0,12 \text{ kW} \leq P < 0,75 \text{ kW}$ a 2, 4, 6, 8 poli, ad esclusione dei motori Ex-eb devono essere **IE2**.

Dal 1° luglio 2022:

oltre alle varie informazioni da riportare nei Data Sheet e nella documentazione tecnica del motore (efficienza nominale, livello IE di efficienza, nome del costruttore, modello del motore, n° di poli, ecc...) bisognerà riportare anche le perdite espresse in percentuale della potenza nominale, determinate su differenti punti di funzionamento di velocità e di coppia:

(25;25), (25;100), (50;25), (50;50), (50;100), (90;50), (90;100)

Dal 1° luglio 2023:

- i motori Ex-eb da $0,12 \text{ kW} \leq P \leq 1.000 \text{ kW}$ a 2, 4, 6, 8 poli devono essere **IE2**.
- i motori monofase con $P \geq 0,12 \text{ kW}$ devono essere **IE2**.
- i motori trifase da $75 \text{ kW} \leq P \leq 200 \text{ kW}$ a 2, 4, 6 poli, ad esclusione dei autofrenanti, dei sicurezza aumentata e degli Exd devono essere **IE4**.

Nota:

nelle esclusioni ci sono i motori TENV (Totally Enclosed Non Ventilated) ma non i TEAO (Totally Enclosed Air Over) che quindi sono nello scopo.



CONTACTS

Head Quarter

FELM srl

Via Morandi (Industrial Area)

20010 Inveruno (Mi) Italy

Tel. +39 02 97 289 454

Tel. +39 02 97 288 320

Fax +39 02 97 289 923

E-mail home@felm.it

FELM Office Middle East

Jebel Ali Free Zone, Warehouse no. FZS1-BM07,

PO Box 263632, Dubai, United Arab Emirates

Office Ph. +971 (04) 887 9767

mobile +971 50 550 1322

Email: ayman.abdallah@felm.it

FELM Office Germany

Heinrich-Busold-Strasse 47

D-61169 Friedberg (Hessen), Germany

Tel (Off): +49-6031-721606

Mobile: +49-172-6729011

Fax: +49-6031-721610

Email: Jayant@jk-conrep.de

FELM Office China

Add: Room 1002, Building 3#,

No 139 Rd.SongShan,

Jianye, Nanjing, Jiangsu, China

Fax:+86-25-87797622

Tel:+86-15077829999

Email: lidongming1974@vip.sina.com

FELM Office UK

The Foundry, Wadebridge

Cornwall, PL27 7JP

United Kingdom

Tel (Off): +441208 816543

Email: sales@felm.co.uk

WORLD WIDE SERVICE

Mobile +39 355 69 53 804

E-mail service@felm.it



ISO 14001





LARGE COMPACT MOTORS

LOW VOLTAGE – HIGH EFFICIENCY & HIGH POWER





GENERAL CHARACTERISTICS

The designing, manufacturing and testing of squirrel cage induction motors made by FELM® are in according to IEC standard, Felm supply high quality cast iron motors with high performance and flexibility to meet the customer request. The motors are widely used in various industries of mining, pumps, compressors, wind machineries, fans ect.

Compact Series Motors Technical details:

Efficiency level: Premium IE3 Motors < 220 kW - > 1000 kW	High efficiency level
Number of Poles: 2 up to 12	
Frequency: 50 Hz.	(Optional: 60 Hz.)
Voltage: 400 V.	(Optional: other rated voltages)
Frames: 315 up to 560	
Cast iron frame	
Cooling system: IC411	(Options: IC416 Inverter use rated 1:10)
Die cast Aluminum Rotor	
Color: RAL 5010 (Blue)	(Options: others type of colour)
Shaft sealing: O´Ring	
VPI Insulation System	
Insulation class F (class B temperature rise)	(Options: Class H)
Random winding from 315X/355X/400X/450X	
Formed winding for 500X and 560X frame	
Degree of protection: IP55	(Options: IP56 - IP65)
Mounting: B3	(Options: B35 - V1)
Painting plan:	(Options: Marine - Chemical - Munsell)
Internal epoxy coating (tropicalized)	
Sintered drain plug	
Terminal block on top	
Shaft Material: C45	
Double grounding (1 inside terminal box + 2 on the frame)	
Grease Caltex SRI-2 or SKF LGHP2	(Different types recommended by Felm)
Regreasing system for frames 315 up to 560	
Options:	
Space Heaters connected in separate auxiliary terminal box	
Predisposition and All type of Encoder	
Special shaft materials	
DC or AC Brake	



Technical data 2 pole – 4 pole

Motor Type		Rated Power		Rated Speed	Efficiency	Power Factor	Current			Torque			Moment of inertia (J)	Weight Approx	Noise level
							Full Load 400V	Full Load 690V	Locked Rotor	Full Load	Locked Rotor	Pull Out			
		kW	(HP)	RPM	%	%	A	A	%FLC	kg-m	%FLT	%FLT	kg-m ²	Kg	dB(A)
F3X	315XA-2	220	295	2978	95,1	88,0	379	220	700	72	150	200	2.2	1580	84
F3X	315XB-2	250	335	2978	95,2	88,0	431	250	700	82	150	200	2.4	1610	84
F3X	315XC-2	280	375	2978	95,3	88,0	482	279	700	92	150	200	2.6	1700	84
F3X	315XD-2	315	420	2978	95,4	88,0	542	314	700	103	150	200	2.8	1900	84
F3X	355XA-2	355	475	2978	95,5	89,0	603	349	700	116	140	200	5.0	2250	86
FX	355XB-2	400	535	2978	95,6	89,0	679	393	700	131	140	200	5.3	2300	86
FX	355XC-2	450	605	2978	95,7	89,0	763	442	700	147	140	200	5.9	2470	86
FX	355XD-2	500	670	2978	95,8	89,0	846	491	700	164	140	200	6.4	2580	87
FX	400XA-2	560	750	2980	95,8	89,0	948	550	750	183	120	200	8	3350	87
FX	400XB-2	630	845	2980	95,8	89,0	1067	618	750	206	120	200	9	3500	87
FX	400XC-2	710	950	2980	95,8	89,0	1202	697	750	232	120	200	11	3680	87
FX	450XA-2	800	1070	2985	95,9	89,0	--	784	750	261	110	200	29	5100	89
FX	450XB-2	900	1205	2985	96,0	89,0	--	881	750	294	110	200	33	5300	89
FX	450XC-2	1000	1340	2985	96,1	89,0	--	978	750	326	110	200	38	5600	89
F3X	315XA-4	220	295	1485	95,2	87,0	383	222	700	144	150	200	3	1690	80
F3X	315XB-4	250	335	1485	95,3	87,0	435	252	700	164	150	200	3.5	1760	80
F3X	315XC-4	280	375	1485	95,5	87,0	486	282	700	184	150	200	4	1870	82
F3X	315XD-4	315	420	1485	95,5	87,0	547	317	700	207	150	200	4.5	2000	82
F3X	315XE-4	355	475	1485	95,6	87,0	616	357	700	233	150	200	5	2090	82
FX	355XA-4	400	535	1485	95,7	87,0	693	402	700	262	140	200	10	2420	82
FX	355XB-4	450	605	1485	95,8	87,0	779	452	700	295	140	200	11	2580	82
FX	355XC-4	500	670	1485	95,8	87,0	866	502	700	328	140	200	12	2800	84
FX	355XD-4	560	750	1485	95,9	87,0	969	562	700	367	120	220	13	3000	84
FX	400XA-4	560	750	1488	95,9	87,0	969	562	700	367	120	220	16	3250	85
FX	400XB-4	630	845	1488	95,9	88,0	1078	625	700	413	120	220	19	3510	85
FX	400XC-4	710	950	1488	96,0	88,0	1213	703	700	465	120	220	22	3790	85
FX	400XD-4	800	1070	1488	96,0	88,0	1367	792	700	524	120	220	26	4070	87
FX	450XA-4	800	1070	1488	96,0	88,0	--	792	700	524	120	220	34	4900	87
FX	450XB-4	900	1205	1490	96,1	88,0	--	891	750	589	110	220	37	5200	89
FX	450XC-4	1000	1340	1490	96,2	88,0	--	988	750	654	110	220	40	5500	89
FX	500XA-4	1000	1340	1490	96,2	88,0	--	988	750	654	110	220	47	6180	**
FX	500XB-4	1120	1500	1490	96,2	88,0	--	1107	750	733	110	220	53	6480	**
FX	500XC-4	1250	1680	1492	96,3	88,0	--	1234	750	816	90	200	60	6820	**
FX	500XD-4	1400	1880	1492	96,4	88,0	--	1381	750	914	90	200	68	7140	**
FX	560XA-4	1400	1880	1492	96,4	88,0	--	1381	750	914	90	200	75	8100	**
FX	560XB-4	1600	2140	1490	96,3	89,0	--	1562	750	1046	80	200	83	8500	**
FX	560XC-4	1800	2410	1490	96,4	89,0	--	1756	750	1177	80	200	92	9050	**

F3X = IE3 Efficiency

** = on request

Technical data 6 pole – 8 pole



Motor Type		Rated Power		Rated Speed	Efficiency	Power Factor	Current			Torque			Moment of inertia (J)	Weight Approx	Noise level
							Full Load 400V	Full Load 690V	Locked Rotor	Full Load	Locked Rotor	Pull Out			
		kW	(HP)	RPM	%	%	A	A	%FLC	kg-m	%FLT	%FLT	kg-m ²	Kg	dB(A)
F3X	315XA-6	200	270	990	95,0	85,0	358	207	650	197	140	200	4	1740	80
F3X	315XB-6	220	295	990	95,1	85,0	393	228	650	217	140	200	5	1850	80
F3X	315XC-6	250	335	990	95,1	85,0	446	259	650	246	140	200	6	1970	80
F3X	315XD-6	280	375	990	95,2	85,0	499	290	650	276	140	200	7	2120	80
F3X	355XA-6	315	420	990	95,2	85,0	562	326	650	310	130	200	14	2410	80
F3X	355XB-6	355	475	990	95,3	85,0	633	367	650	349	130	200	15	2650	82
FX	355XC-6	400	535	990	95,4	85,0	712	413	650	394	130	200	16	2800	82
FX	400XA-6	450	605	990	95,6	86,0	790	458	680	443	120	200	24	3650	83
FX	400XB-6	500	670	990	95,7	86,0	877	508	680	492	120	200	26	3750	83
FX	400XC-6	560	750	990	95,8	86,0	981	569	680	551	120	200	28	3880	83
FX	450XA-6	630	845	990	95,9	86,0	1103	639	700	620	110	200	47	4800	85
FX	450XB-6	710	950	990	95,9	86,0	1243	720	700	699	110	200	50	5000	85
FX	450XC-6	800	1070	990	96,0	86,0	1399	811	700	787	110	200	53	5250	85
FX	500XA-6	900	1205	990	96,0	86,0	--	912	700	886	100	200	89	6750	85
FX	500XB-6	1000	1340	990	96,1	86,0	--	1012	700	984	100	200	96	7020	85
FX	500XC-6	1120	1500	990	96,1	86,0	--	1134	700	1102	100	200	103	7300	**
FX	560XA-6	1250	1680	992	96,2	86,0	--	1264	700	1228	90	200	120	8300	**
FX	560XB-6	1400	1880	992	96,3	86,0	--	1415	700	1375	90	200	140	8600	**
FX	560XC-6	1600	2140	992	96,4	86,0	--	1615	700	1572	90	200	160	9150	**
FX	315XA-8	160	215	740	94,4	78,0	314	182	650	211	130	200	4	1740	78
FX	315XB-8	180	240	740	94,5	78,0	352	204	650	237	130	200	5	1850	78
FX	315XC-8	200	270	740	94,6	78,0	391	227	650	263	130	200	6	1970	78
FX	315XD-8	220	295	740	94,7	78,0	430	249	650	290	130	200	7	2120	78
FX	355XA-8	250	335	740	94,9	80,0	475	276	650	329	120	200	15	2590	80
FX	355XB-8	280	375	740	95,0	80,0	532	308	650	369	120	200	16	2750	80
FX	355XC-8	315	420	740	95,1	80,0	598	346	650	415	120	200	17	2970	80
FX	400XA-8	355	475	742	95,2	81,0	665	385	650	466	120	200	24	3410	82
FX	400XB-8	400	535	742	95,3	81,0	748	434	650	525	120	200	26	3560	82
FX	400XC-8	450	605	742	95,4	81,0	841	487	650	591	120	200	28	3800	82
FX	400XD-8	500	670	742	95,5	81,0	933	541	650	657	120	200	31	4100	82
FX	450XA-8	500	670	742	95,5	81,0	933	541	650	657	120	200	47	4760	**
FX	450XB-8	560	750	742	95,6	81,0	1044	605	650	735	120	200	49	5080	**
FX	450XC-8	630	845	742	95,6	81,0	1174	681	650	827	120	200	51	5430	**
FX	500XA-8	630	845	744	95,6	81,0	1174	681	650	825	110	200	88	5780	**
FX	500XB-8	710	950	744	95,7	82,0	--	757	650	930	110	200	96	6080	**
FX	500XC-8	800	1070	744	95,8	82,0	--	852	650	1048	110	200	104	6440	**
FX	500XD-8	900	1205	744	95,9	82,0	--	958	650	1179	110	200	112	6760	**
FX	560XA-8	900	1205	744	95,9	82,0	--	958	650	1179	110	200	132	7800	**
FX	560XB-8	1000	1340	745	96,0	82,0	--	1063	650	1308	100	200	145	8210	**
FX	560XC-8	1120	1500	745	96,1	82,0	--	1189	650	1465	100	200	160	8610	**
FX	560XB-8	1250	1680	745	96,2	82,0	--	1326	650	1635	100	200	175	9120	**

F3X = IE3 Efficiency

** = on request

Motor Type		Rated Power		Rated Speed	Efficiency	Power Factor	Current			Torque			Moment of inertia (J)	Weight Approx	Noise level
							Full Load 400V	Full Load 690V	Locked Rotor	Full Load	Locked Rotor	Pull Out			
		kW	(HP)	RPM	%	%	A	A	%FLC	kg-m	%FLT	%FLT	kg-m ²	Kg	dB(A)
FX	400X0-10	250	335	592	94,9	78,0	487	283	550	412	120	200	24	3310	**
FX	400XA-10	280	375	592	95,0	78,0	545	316	550	461	120	200	26	3490	**
FX	400XB-10	315	420	592	95,0	78,0	614	356	550	519	120	200	28	3670	**
FX	400XC-10	355	475	592	95,1	78,0	691	400	550	584	120	200	31	3970	**
FX	450XA-10	355	475	592	95,1	79,0	682	395	600	584	110	200	46	4680	**
FX	450XA-10	400	535	592	95,2	79,0	768	445	600	658	110	200	48	5070	**
FX	450XB-10	450	605	592	95,3	79,0	863	500	600	741	110	200	50	5250	**
FX	450XC-10	500	670	592	95,3	79,0	959	556	600	823	110	200	53	5460	**
FX	500XA-10	500	670	592	95,3	80,0	947	549	600	823	110	200	76	5800	**
FX	500XB-10	560	750	592	95,4	80,0	1059	614	600	922	110	200	82	6170	**
FX	500XC-10	630	845	592	95,5	80,0	1190	690	600	1037	110	200	87	6400	**
FX	500XD-10	710	950	592	95,6	80,0	1340	777	600	1169	110	200	92	6720	**
FX	560XA-10	710	950	595	95,6	80,0	--	777	600	1163	110	200	126	7800	**
FX	560XB-10	800	1070	595	95,6	80,0	--	875	600	1310	100	200	138	8200	**
FX	560XC-10	900	1210	595	95,7	81,0	--	972	600	1474	100	200	150	8610	**
FX	560XD-10	1000	1340	595	95,7	81,0	--	1079	600	1638	100	200	162	9120	**
FX	355XA-12	132	175	490	94,2	71,0	285	165	500	263	110	200	16	2450	**
FX	355XB-12	160	215	490	94,3	71,0	345	200	500	318	110	200	17	2660	**
FX	355XC-12	180	240	490	94,4	71,0	388	225	500	358	110	200	18	2850	**
FX	400XA-12	200	270	492	94,5	72,0	424	246	500	396	110	200	24	3300	**
FX	400XB-12	225	300	492	94,6	72,0	477	276	500	446	110	200	26	3450	**
FX	400XC-12	250	335	492	94,7	72,0	529	307	500	495	110	200	28	3600	**
FX	400XD-12	280	375	492	94,8	72,0	592	343	500	555	110	200	31	3900	**
FX	450XA-12	280	375	492	94,8	73,0	584	339	550	555	100	180	46	4630	**
FX	450XB-12	315	420	492	94,9	73,0	656	380	550	624	100	180	47	4870	**
FX	450XC-12	355	475	492	95,0	73,0	739	428	550	703	100	180	48	5070	**
FX	450XD-12	400	535	492	95,0	73,0	833	483	550	792	100	180	50	5250	**
FX	500XA-12	450	605	492	95,1	74,0	923	535	550	891	90	180	82	6170	**
FX	500XB-12	500	670	492	95,2	74,0	1024	594	550	990	90	180	87	6400	**
FX	500XC-12	560	750	492	95,2	74,0	1147	665	550	1109	90	180	92	6720	**
FX	560XA-12	630	840	495	95,3	75,0	--	738	600	1240	90	180	125	8200	**
FX	560XB-12	710	950	495	95,4	75,0	--	830	600	1398	90	180	135	8610	**
FX	560XC-12	800	1070	495	95,5	75,0	--	935	600	1575	90	180	150	9120	**

F3X = IE3 Efficiency

** = on request

B3

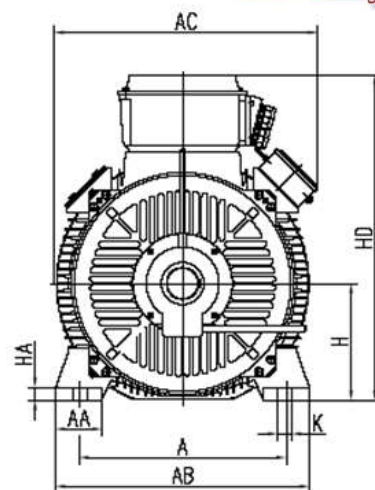
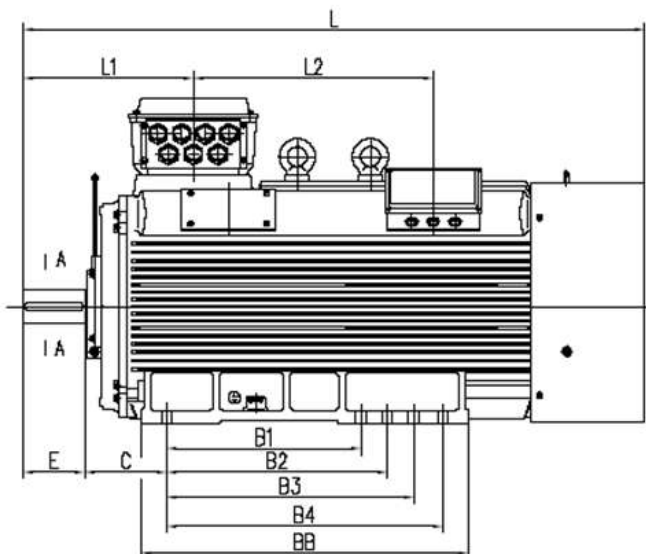

Frame	Pole	MOUNTING												
		A	B1	B2	B3	B4	C	D	E	F	G	H	K	
315X	2	508/560	630	710	800	-	216±4	65 ^{+0.03} / _{+0.01}	140±0.5	18 ⁰ / _{-0.043}	58 ⁰ / _{-0.2}	315 ⁰ / ₋₁	28*54	
315X	4	508/560	630	710	800	-	216±4	80 ^{+0.03} / _{+0.01}	170±0.5	22 ⁰ / _{-0.052}	71 ⁰ / _{-0.2}	315 ⁰ / ₋₁	28*54	
355X	2	630±1.4	630	710	800	-	254±4	75 ^{+0.03} / _{+0.01}	140±0.5	20 ⁰ / _{-0.052}	67,5 ⁰ / _{-0.2}	355 ⁰ / ₋₁	35 ^{+0.5} / ₀	
355X	4~12	630±1.4	630	710	800	-	254±4	100 ^{+0.03} / _{+0.01}	210±0.5	25 ⁰ / _{-0.052}	86 ⁰ / _{-0.2}	355 ⁰ / ₋₁	35 ^{+0.5} / ₀	
400X	2	686/710	710	800	900	-	280±4	80 ^{+0.03} / _{+0.01}	170±0.5	22 ⁰ / _{-0.052}	71 ⁰ / _{-0.2}	400 ⁰ / ₋₁	35*47	
400X	4~12	686/710	710	800	900	-	280±4	110 ^{+0.03} / _{+0.01}	210±0.57	28 ⁰ / _{-0.052}	100 ⁰ / _{-0.2}	400 ⁰ / ₋₁	35*47	
450X	2	800±1.75	900	1000	1120	1250	280±4	95 ^{+0.03} / _{+0.01}	170±0.5	25 ⁰ / _{-0.052}	86 ⁰ / _{-0.2}	450 ⁰ / ₋₁	35 ^{+0.6} / ₀	
450X	4~12	800±1.75	900	1000	1120	1250	280±4	120 ^{+0.03} / _{+0.01}	210±0.57	32 ⁰ / _{-0.062}	109 ⁰ / _{-0.2}	450 ⁰ / ₋₁	35 ^{+0.6} / ₀	
500X	4~12	900±2.1	1250 ±2.1				315±4	140 ^{+0.04} / _{+0.01}	250±0.57	36 ⁰ / _{-0.062}	128 ⁰ / _{-0.3}	500 ⁰ / ₋₁	42*60	
560X	4~8	1000±2.1	1400 ±2.1				355±4	160 ^{+0.04} / _{+0.01}	300±0.65	40 ⁰ / _{-0.062}	147 ⁰ / _{-0.3}	560 ⁰ / ₋₁	42*52	

Frame	Pole	OUTLINE									
		AC	AA	AB	BB	HA	HD	L1	L2	L	
315X	2	700	120	680	1080	45	845	462	797	1790	
315X	4	700	120	680	1080	45	845	492	797	1820	
355X	2	790	135	760	1140	52	1020	508	841	1880	
355X	4~12	790	135	760	1140	52	1020	538	841	1910	
400X	2	864	160	870	1200	50	1100	512	700	2000	
400X	4~12	864	160	870	1200	50	1100	572	700	2040	
450X	2	1035	225	980	1495	45	1290	570	921	2380	
450X	4~12	1035	225	980	1495	45	1290	610	921	2420	
500X	4~12	1095	180	1080	1600	65	1365	662	980	2560	
560X	4~12	1195	210	1170	1680	76	1480	710	970	2700	

B3/B5

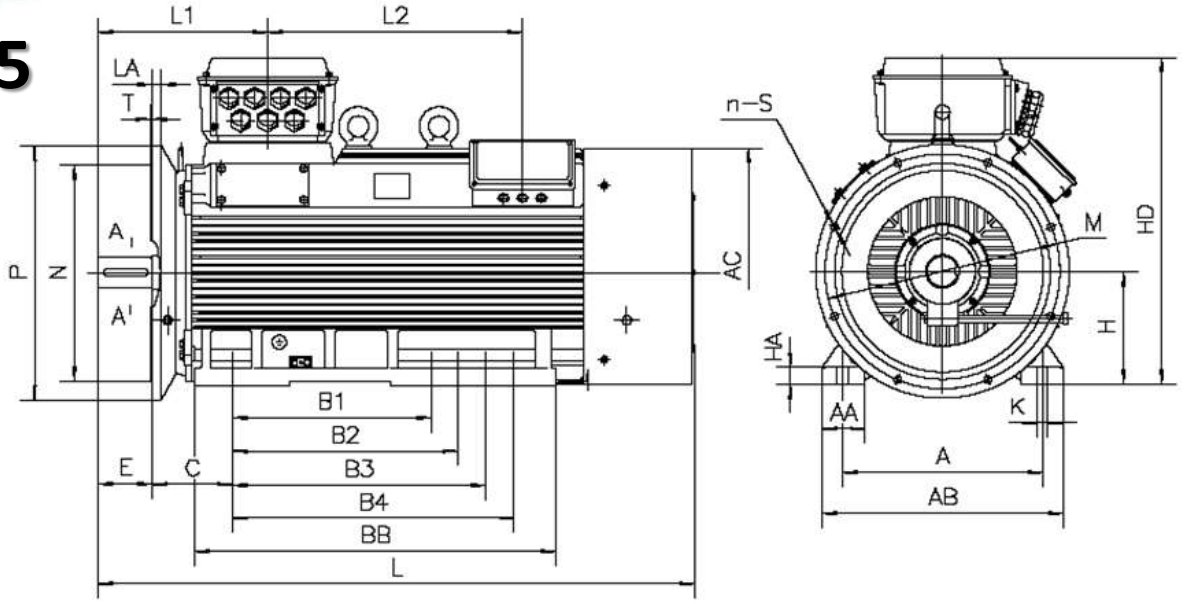

Frame	Pole	MOUNTING											
		A	B1	B2	B3	B4	C	D	E	F	G	H	K
315X	2	508/560	630	710	800	-	216±4	65 ^{+0.030} _{+0.011}	140±0.5	18 ⁰ ₋	58 ⁰ ₋	315 ⁰ ₋₁	28*54
315X	4	508/560	630	710	800	-	216±4	80 ^{+0.030} _{+0.011}	170±0.5	22 ⁰ ₋	71 ⁰ ₋	315 ⁰ ₋₁	28*54
355X	2	630±1.4	630	710	800	-	254±4	75 ^{+0.030} _{+0.011}	140±0.5	20 ⁰ ₋	67,5 ⁰ ₋	355 ⁰ ₋₁	35 ^{+0.5} ₀
355X	4~12	630±1.4	630	710	800	-	254±4	100 ^{+0.035} _{+0.013}	210±0.5	25 ⁰ ₋	86 ⁰ ₋	355 ⁰ ₋₁	35 ^{+0.5} ₀
400X	2	686/710	710	800	900	-	280±4	80 ^{+0.030} _{+0.011}	170±0.5	22 ⁰ ₋	71 ⁰ ₋	400 ⁰ ₋₁	35*47
400X	4~12	686/710	710	800	900	-	280±4	110 ^{+0.035} _{+0.013}	210±0.57	28 ⁰ ₋	100 ⁰ ₋	400 ⁰ ₋₁	35*47
450X	2	800±1.75	900	1000	1120	1250	280±4	95 ^{+0.035} _{+0.013}	170±0.5	25 ⁰ ₋	86 ⁰ ₋	450 ⁰ ₋₁	35 ^{+0.6} ₀
450X	4~12	800±1.75	900	1000	1120	1250	280±4	120 ^{+0.035} _{+0.013}	210±0.57	32 ⁰ ₋	109 ⁰ ₋	450 ⁰ ₋₁	35 ^{+0.6} ₀
500X	4~12	900±2.1	1250±2.1				315±4	140 ^{+0.04} _{+0.015}	250±0.57	36 ⁰ ₋	128 ⁰ ₋	500 ⁰ ₋₁	42*60
560X	4~8	1000±2.1	1400±2.1				355±4	160 ^{+0.04} _{+0.015}	300±0.65	40 ⁰ ₋	147 ⁰ ₋	560 ⁰ ₋₁	42*52

Frame	Pole	OUTLINE						OUTLINE								
		M	N	P	S	T	LA	AA	AB	AC	BB	HA	HD	L1	L2	L
315X	2	600	550	660	8-24	6	22	120	680	700	1080	45	845	462	797	1790
315X	4	600	550	660	8-24	6	22	120	680	700	1080	45	845	492	797	1820
355X	2	740	680	800	8-24	6	25	135	760	790	1140	52	1020	508	841	1880
355X	4~12	740	680	800	8-24	6	25	135	760	790	1140	52	1020	538	841	1910
400X	2	940	880	1000	8-28	6	28	160	870	864	1200	50	1100	512	700	2000
400X	4~12	940	880	1000	8-28	6	28	160	870	864	1200	50	1100	572	700	2040
450X	2	1080	1000	1150	8-28	6	30	225	980	1035	1495	45	1290	570	921	2380
450X	4~12	1080	1000	1150	8-28	6	30	225	980	1035	1495	45	1290	610	921	2420
500X	4~12	1180	1120	1250	8-28	7	32	180	1080	1095	1600	65	1365	662	980	2560
560X	4~12	1180	1120	1250	8-28	7	32	210	1170	1195	1680	76	1480	710	970	2700

V1

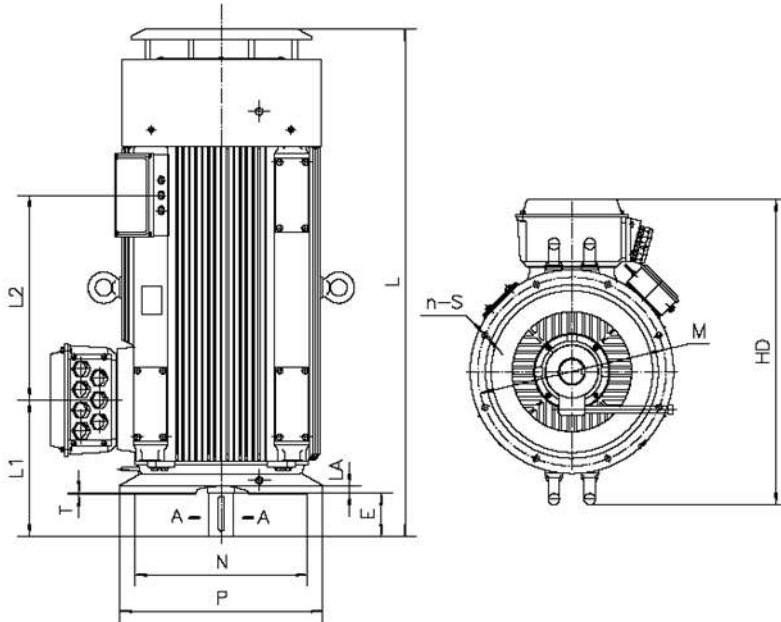

Frame	Pole	MOUNTING																
		D	E	F	G	M	N	P	n-S	T	LA	HD	L1	L2	L			
315X	4	80	+0.03 +0.01	170	22	0 -	71	0 -	600	550	660	8-24	6	22	990	492	797	2020
355X	4~12	100	+0.03 +0.01	210	25	0 -	86	0 -	740	680	800	8-24	6	25	1190	538	841	2250
400X	4~12	110	+0.03 +0.01	210	28	0 -	100	0 -	940	880	1000	8-28	6	28	1270	572	700	2380
450X	4~12	120	+0.03 +0.01	210	32	0 -	109	0 -	1080	1000	1150	8-28	6	30	1520	610	921	2600
500X	4~12	140	+0.04 +0.01	250	36	0 -	128	0 -	1180	1120	1250	8-28	7	32	1576	662	980	2720
560X	4~12	160	+0.04 +0.01	300	40	0 -	147	0 -	1180	1120	1250	8-28	7	32	1681	710	970	2980

Bearings (IMB3)

Frame	Pole	D.E.	N.D.E.
315 X	2	6317C3	6317C3
315 X	4,6,8	6319C3	6319C3
355 X	2	6318C3	6318C3
355 X	4,6,8	6322C3	6322C3
400 X	2	6220C3	6220C3
400 X	4,6,8	6326C3	6326C3
450 X	2	6221C3	6221C3
450 X	4,6,8	6328C3	6328C3
500 X	2	on demand	on demand
500 X	4,6,8	6330C3	6330C3
560 X	2	on demand	on demand
560 X	4,6,8	6334C3	6330C3

Terminal box

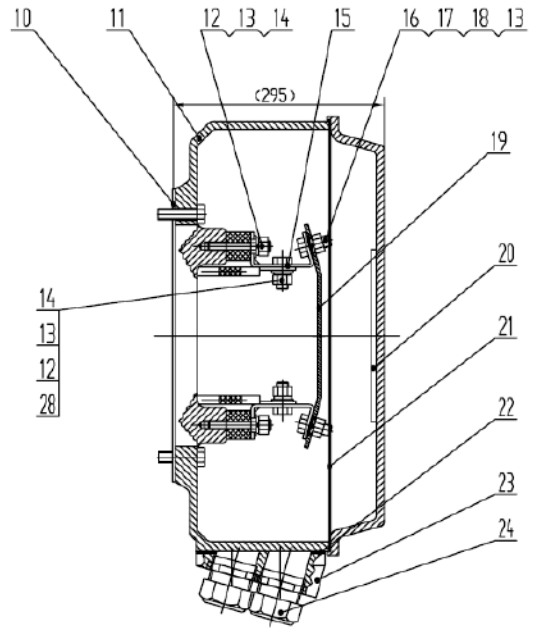
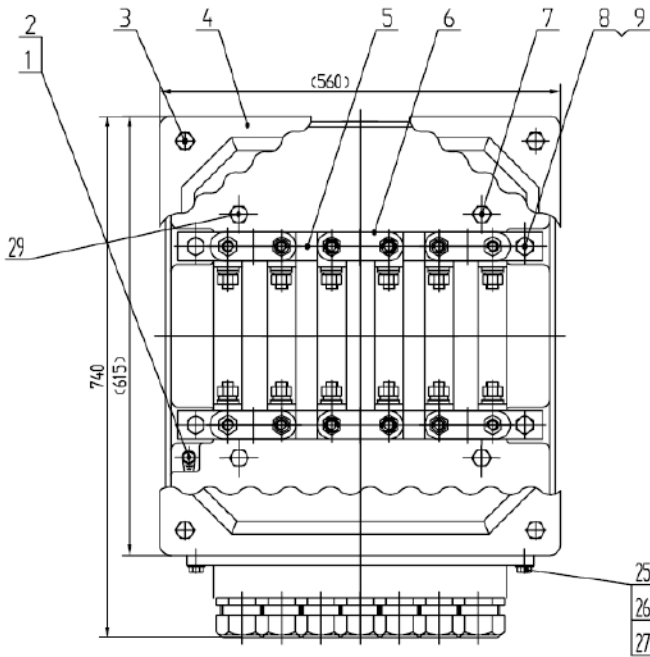

No.	Name	Type	No.	Name	Type	No.	Name	Type
1	Bolt	M12x20	11	Terminal box base		21	Sealing gasket	
2	Label Grounding		12	Gasket		22	Sealing gasket	
3	Bolt	M12x25	13	Gasket		23	Outlet insert	
4	Terminal box lid		14	Nut	M16	24	Cable gland*	7x M63x1,5
5	Connection place		15			25	Bolt	M12x35
6			16	Bolt	M16x50	26	Gasket	
7	Bolt	M16x40	17	Gasket		27	Bolt	M12x35
8	Bolt	M16x60	18	Nut	M16	28	Bolt	M16x50
9	Gasket		19	Connection place		29	Bolt	M16x40
10	Sealing gasket		20	Connection instruction				

*=frame 355-400-500-560
frame 315= 7xM40X1.5



CONTATCS

Head Quarter

FELM srl

Via Morandi (Industrial Area)

20010 Inveruno (Mi) Italy

Tel. +39 02 97 289 454

Tel. +39 02 97 288 320

Fax +39 02 97 289 923

E-mail home@felm.it



FELM Office Germany

Heinrich-Busold-Strasse 47

D-61169 Fridberg (Hessen), Germany

Tel. (Off.) +49 6331 721606

Mobile +49 172 6729011

E-mail Jayant@jk-conrep.de

FELM Office China

Room 1002, Building 3#, No.139 Rd. SongShan

Jianye, Nanjing, Jiangsu, China

Te. +86 150 778 29 999

Fax +86 25 87 797 622

E-mail lidongming1974@vip.sina.com

FELM Office Middle East

Al Saalam Street, Al Darwish Building (NBAD building)

office no. 1403 Abu Dhabi (United Arab Emirates)

P.O. Box 45223

Office Ph. + 971-2-6710330

Office Fax + 971-2-6710255

mobile +971 50 4442093

WORLD WIDE SERVICE

Mobile +39 355 69 53 804

E-mail service@felm.it



ISO 14001



Certificate
EAC - CUTR EurAseC
(Russian Market)



Electric Motors - www.felm.it

INVERTER DUTY MOTORS

LOW VOLTAGE

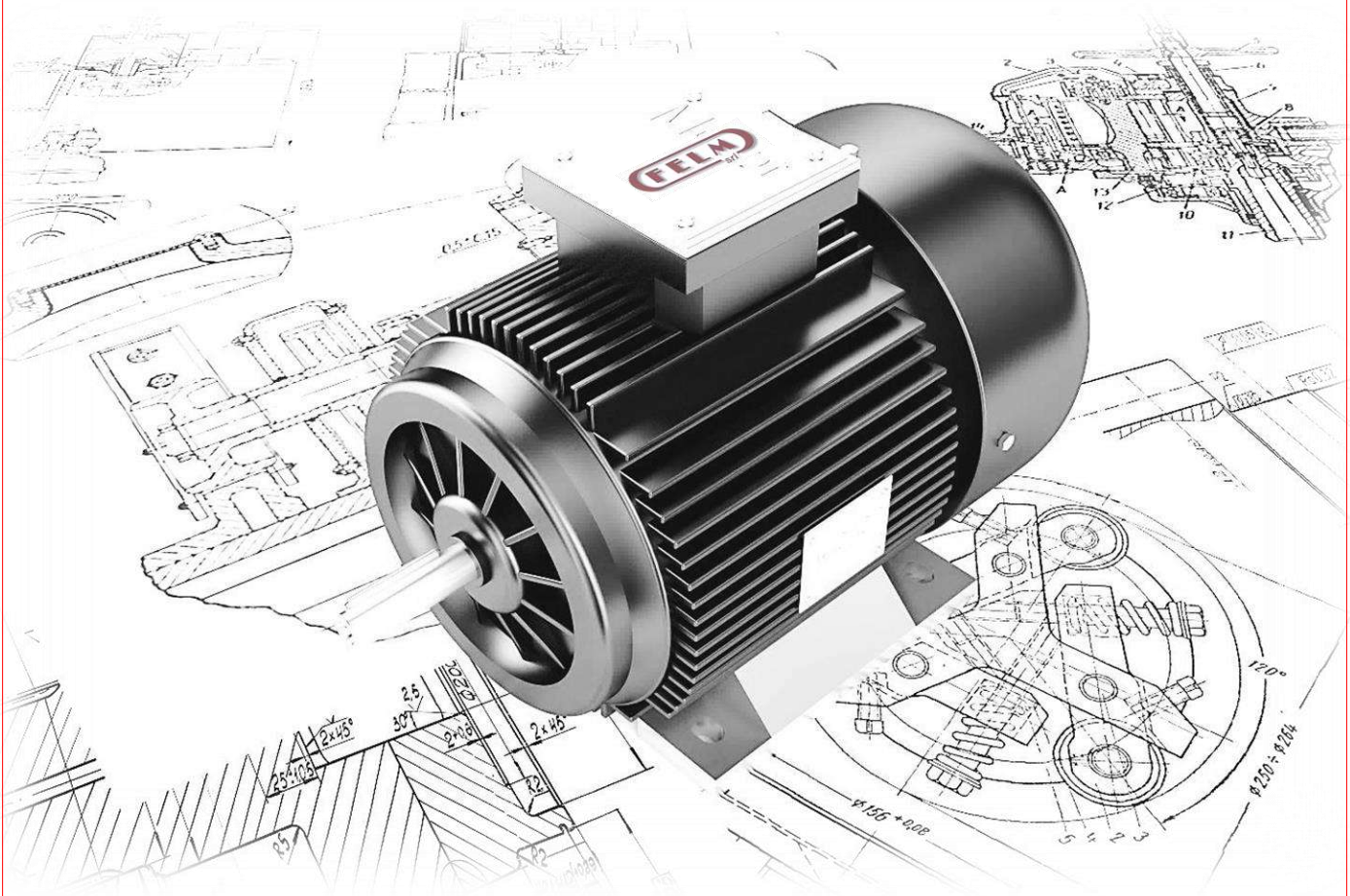

Your Engineering Company of Electric Motors



GENERAL CHARACTERISTICS

The design, manufacturing and testing of squirrel cage induction motors made by FELM® are in according to IEC standard, Felm supply high quality cast iron motors with high performance and technical flexibility to meet the customer request. The motors are widely used in various industries like mining, pumps, compressors, wind machineries, fans ect.

Compact Series Motors Technical details:

Efficiency level: Premium IE2/IE3/IE4 Motors < 220 kW - > 1500 kW High efficiency level

Number of Poles: 2 up to 12

Frequency: 50 Hz.

(Optional: 60 Hz.)

Voltage: 400 V.

(Optional: other rated voltages)

Frames: 315 up to 560

Cast iron frame

Cooling system: IC411

(Options: IC416 Inverter use rated 1:10)

Die cast Aluminum Rotor

Color: RAL 5010 (Blue)

(Options: others type of color)

Shaft sealing: O´Ring

VPI Insulation System

Insulation class F (class B temperature rise)

(Options: Class H)

Random winding from 315X/355X/400X/450X

Formed winding for 500X and 560X frame

Degree of protection: IP55

(Options: IP56 - IP65)

Mounting: B3

(Options: B35 - V1)

Painting plan:

(Options: Marine - Chemical - Munsell)

Internal epoxy coating (tropicalized)

Sintered drain plug

Terminal block on top

Shaft Material: C45

Double grounding (1 inside terminal box + 2 on the frame)

Grease Caltex SRI-2 or SKF LGHP2

(Different types recommended by Felm)

Re-greasing system for frames 315 up to 560

Options:

Space Heaters, PT100 connected in separate auxiliary terminal box

Vibration probe/temperature probe

Trip amplifier 4-20 mA signal forced ventilation

Predisposition and All type of Encoder

Special shaft materials, grounding brush

Automatic lubrication on board remote control vibration and temperature

DC or AC Brake

- Standard mounting: IEC60034-F - Standard protection: IEC60034-5
- Variable frequency motors whose are designed to be lead by frequency converter can work under variable-frequency power.
- Vacuum Pressure Impregnation (VPI)
- Double insulated reinforced copper wires.
- Special insulation system, high frequency harmonic shock resistance.
- For heavy application windings in copper bar.
- Insulating bearings construction for shaft voltage resistance, SKF Insocoat bearings.
- Power range: 0.55~1800 kW.
- Frame range: H 80~H 630.
- Motors are equipped with a faire cooling ventilation under different speed.
- IC416 Cooling, upon request.
- Specific winding can be used for various voltages (50Hz or 60Hz).
- Motors can be equipped with encoder that can fluently start and precisely controlled.
- PTC, PT100 and other thermal elements can be chosen to protect winding and bearings.
- Heater can be added to prevent moisture.

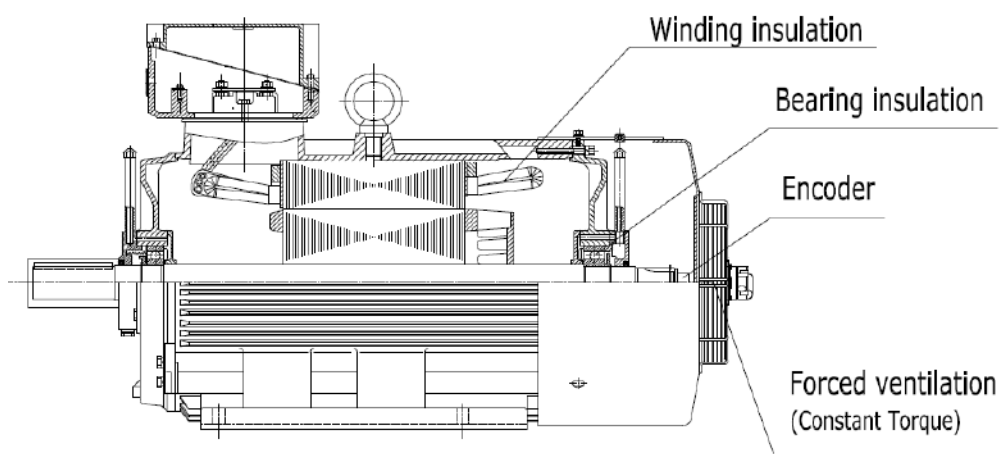

In the case of higher values it is suggested to use a suitable filter between the motor and the inverter to reduce the stress on the motor.

A filter is required in case of excessive length of the power cables (distance between motor and inverter greater than 65 mt.)

A Without filters for motors up to 500 V a.c.

B Without filters for motors up to 690 V a.c.

* Examples of measured results at 415 V supply, for different lengths of steel armored cable

Rules IEC 60034-25

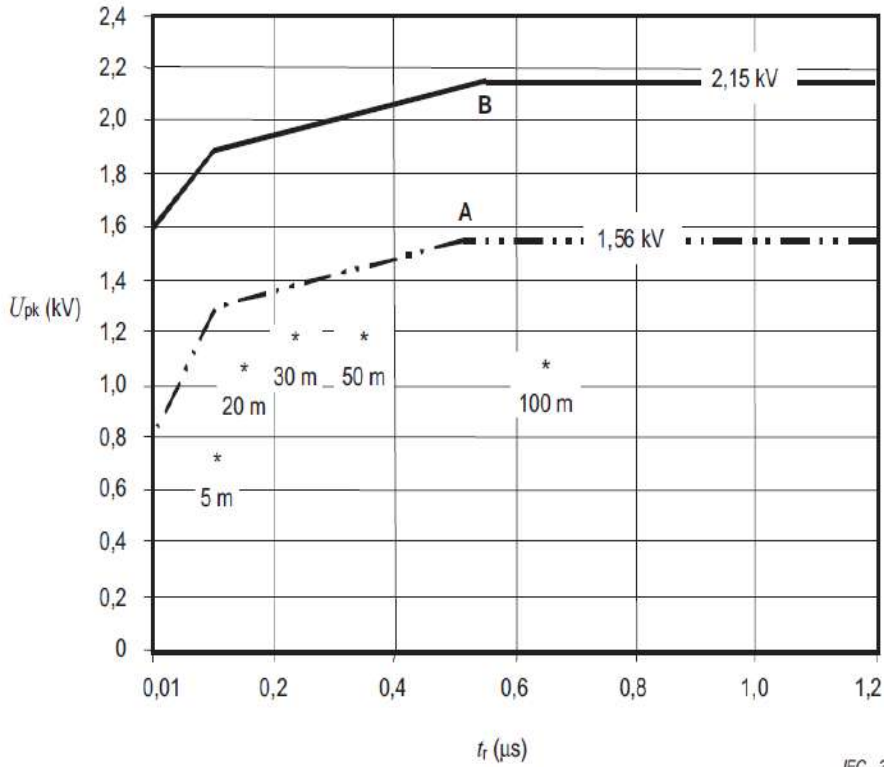

IEC 368/07

Waveform output from the inverter

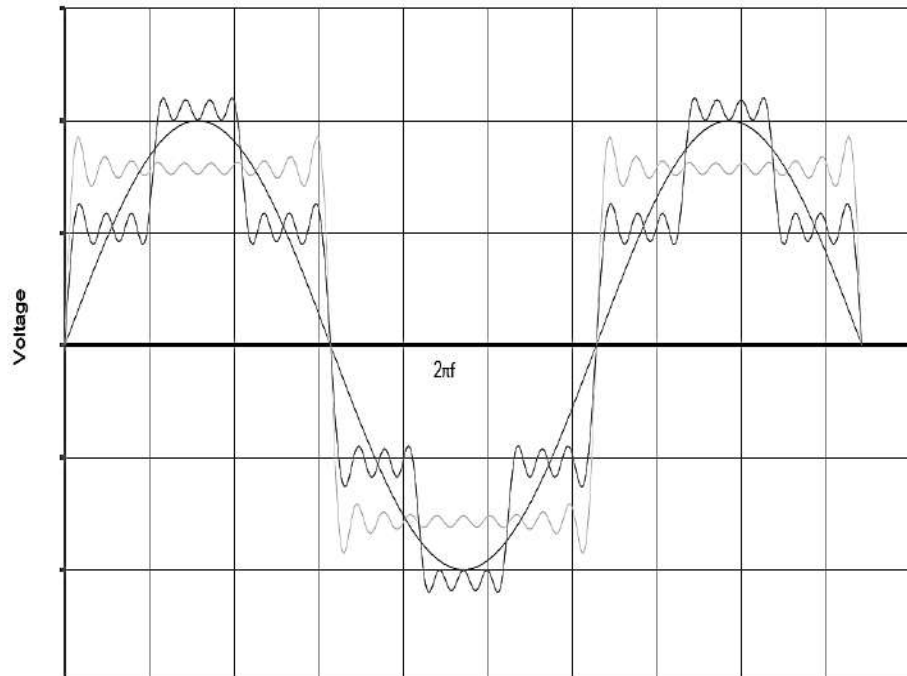

4 Pole

Type	Output	Current	Rated Torque	Break-down torque /rated torque multiple	Rated speed	Weight Kg. (approx)	
	kW	A	Nm		r/min	IC416	IC411
F2-VP 90S-4	1,1	2,8	7,53	2,8	1395	24	22
F2-VP 90L-4	1,5	3,7	10,1	2,8	1412	29	28
F2-VP 100L1-4	2,2	5,08	14,7	2,8	1431	36	34
F2-VP 100L2-4	3	6,86	20	2,8	1431	40	38
F2-VP 112M-4	4	8,48	26,5	2,8	1438	48	44
F2-VP 132S-4	5,5	11,7	36,3	2,8	1445	70	61
F2-VP 132M-4	7,5	15,1	49,5	2,8	1445	82	73
F2-VP 160M-4	11	22	72,4	2,8	1451	125	113
F2-VP 160L-4	15	29,5	98,5	2,8	1452	145	133
F2-VP 180M-4	18,5	35	120	2,8	1465	187	167
F2-VP 180L-4	22	42	143	2,8	1464	201	181
F2-VP 200L-4	30	56,6	195	2,8	1468	257	232
F2-VP 225S-4	37	70,6	240	2,8	1472	317	287
F2-VP 225M-4	45	84,9	290	2,8	1477	352	322
F2-VP 250M-4	55	120	355	2,8	1477	411	381
F2-VP 280S-4	75	137	483	2,8	1481	545	510
F2-VP 280M-4	90	163	580	2,8	1481	635	600
F2-VP 315S-4	110	204	707	2,8	1485	961	921
F2-VP 315M-4	132	237	848	2,8	1485	1042	1002
F2-VP 315L-4	160	282	1028	2,8	1486	1110	1070
F2-VP 315LX-4	200	360	1281	2,8	1491	1221	1181
F2-VP 355M-4	250	444	1600	2,8	1492	1765	1720
F2-VP 355L-4	315	558	2015	2,8	1493	1995	1950

Major power on request



6 Pole

Type	Output	Current	Rated Torque	Break-down torque /rated torque multiple	Rated speed	Weight Kg. (approx)	
	kW	A	Nm		r/min	IC416	IC411
F2-VP 90S-6	0,75	2,29	7,76	2,8	922	25	23
F2-VP 90L-6	1,1	3,15	11,4	2,8	918	29	25
F2-VP 100L-6	1,5	3,96	15,3	2,8	933	36	33
F2-VP 112M-6	2,2	5,27	22,2	2,8	946	43	39
F2-VP 132S-6	3	7,36	29,6	2,8	965	64	56
F2-VP 132M1-6	4	9,52	39,5	2,8	965	79	71
F2-VP 132M2-6	5,5	12,5	54,3	2,8	967	83	75
F2-VP 160M-6	7,5	16,8	74	2,8	968	120	108
F2-VP 160L-6	11	32	108	2,8	966	143	131
F2-VP 180L-6	15	30,8	146	2,8	976	191	171
F2-VP 200L1-6	18,5	37,3	180	2,8	978	246	216
F2-VP 200L2-6	22	43,9	215	2,8	976	255	225
F2-VP 225M-6	30	58,9	291	2,8	984	322	292
F2-VP 250M-6	37	69,3	360	2,8	981	438	408
F2-VP 280S-6	45	84,2	436	2,8	985	500	465
F2-VP 280M-6	55	102	535	2,8	983	575	540
F2-VP 315S-6	75	143	723	2,8	990	901	861
F2-VP 315M-6	90	173	870	2,8	988	980	940
F2-VP 315L-6	110	206	1063	2,8	988	1150	1110
F2-VP 315LX-6	132	243	1275	2,8	989	1215	1175
F2-VP 355M-6	160	283	1540	2,8	992	1735	1690
F2-VP 355MY-6	200	353	1925	2,8	922	1915	1870
F2-VP 355L-6	250	445,4	2409	2,8	991	2025	1980

Major power on request

8 Pole

Type	Output	Current	Rated Torque	Break-down torque /rated torque multiple	Rated speed r/min	Weight Kg. (approx)	
	kW	A	Nm			IC416	IC411
F2-VP 132S-8	2,2	5,92	29,3	2,8	715	70	62
F2-VP 132M-8	3	7,56	40,1	2,8	713	74	66
F2-VP 160M-8	4	9,71	53,2	2,8	718	106	94
F2-VP 160MX-8	5,5	13,3	72,7	2,8	722	118	106
F2-VP 160L-8	7,5	17	99,3	2,8	721	140	128
F2-VP 180L-8	11	24,9	144	2,8	725	190	170
F2-VP 200L-8	15	33,8	196	2,8	731	255	230
F2-VP 225S-8	18,5	40,8	241	2,8	733	297	272
F2-VP 255M-8	22	46,1	286	2,8	734	319	294
F2-VP 250M-8	30	62,2	390	2,8	734	395	370
F2-VP 280S-8	37	75,6	480	2,8	736	510	475
F2-VP 280M-8	45	93,3	583	2,8	767	590	555
F2-VP 315S-8	55	112	710	2,8	740	945	905
F2-VP 315M-8	75	150	968	2,8	740	1021	981
F2-VP 315L-8	90	179	1160	2,8	741	1141	1071
F2-VP 315LX-8	110	217	1415	2,8	742	1200	1160
F2-VP 355M-8	132	252	1694	2,8	744	1845	1800
F2-VP 355MY-8	160	298	2053	2,8	744	1935	1890
F2-VP 355L-8	200	379	2567	2,8	744	2085	2040

Major power on request

All data (technical, dimensions, etc..) listed in the tables are indicative and not binding. The guaranteed values are upon request. Felm srl reserves the right to change the project, the technical characteristics and dimensions at any time without previous notice.

Tutti i dati (tecnici, dimensionali, ecc.) riportati nelle tabelle sono indicativi e non impegnativi. I valori garantiti vengono rilasciati su richiesta. Con l'obiettivo di un continuo sviluppo del Prodotto Motore Elettrico, FELM srl si riserva il diritto di modificare il progetto, le caratteristiche tecniche e dimensionali in qualsiasi momento senza preavviso.

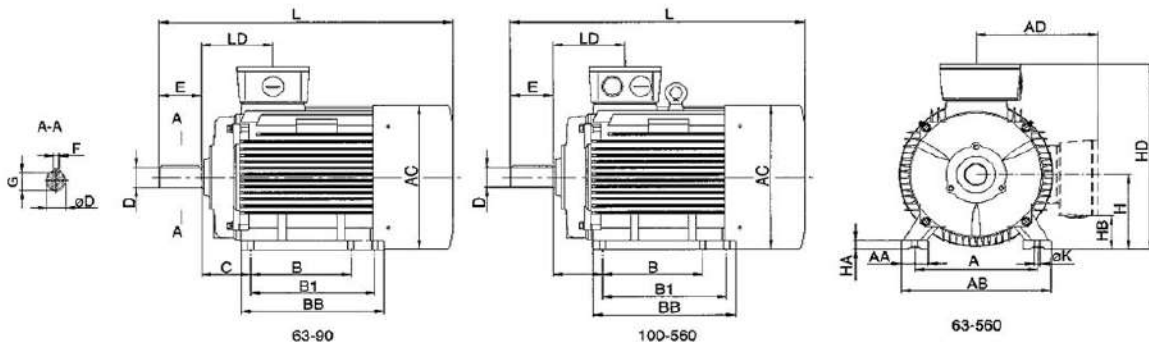

◆ B3

frame	Pole	Dimension								Dimension										
		A	B	B1	C	CA	H	K	AA	AB	AC	AD	BB	HA	HB	HB		LD	L	LC
		On top		L&R																
63	2-8	100	80	-	40	-	63° ^{-0,5}	7	30	135	130	-	115	8	-	180	-	65	225	253
71	2-8	112	90	-	45	-	71° ^{-0,5}	7	32	150	145	-	125	8	-	195	-	70	250	285
80	2-8	125	100	-	50	98	80° ^{-0,5}	10	35	160	160	145	130	12	36	225	160	75	280	336
90S	2-8	140	100	-	58	117	90° ^{-0,5}	10	38	180	180	155	140	12	50	245	180	75	315	373
90L	2-8	140	125	-	58	117	90° ^{-0,5}	10	38	180	180	155	165	12	50	245	180	75	340	373
100L	2-8	160	140	-	63	120	100° ^{-0,5}	12	40	200	200	180	175	14	55	280	200	83	375	443
112M	2-8	190	140	-	70	138	112° ^{-0,5}	12	45	230	220	190	180	15	60	305	222	87	400	468
132S	2-8	216	140	-	89	164	132° ^{-0,5}	12	55	265	260	220	190	18	65	355	262	102	465	553
132M	2-8	216	178	-	89	146	132° ^{-0,5}	12	55	265	260	220	230	18	65	355	262	102	505	593
160M	2-8	254	210	-	108	188	160° ^{-0,5}	15	65	315	315	265	260	20	81	425	385	146	608	726
160L	2-8	254	254	-	108	188	160° ^{-0,5}	15	65	315	315	265	305	20	81	425	385	146	652	770
180M	2.4	279	241	-	121	226	180° ^{-0,5}	15	70	350	360	280	315	22	105	460	420	161	690	808
180L	4-8	279	279	-	121	228	180° ^{-0,5}	15	70	350	360	280	350	22	105	460	420	161	730	848
200L	2-8	318	305	-	133	220	200° ^{-0,5}	19	70	390	400	310	370	25	85	510	475	186	760	878
225S	4-8	356	286	-	149	243	225° ^{-0,5}	19	75	435	450	335	370	28	110	555	535	189	810	928
225M	2	356	311	-	149	243	225° ^{-0,5}	19	75	435	450	335	395	28	110	555	535	189	805	923
	4-8	356	311	-	149	198	225° ^{-0,5}	19	75	435	450	335	395	28	110	555	535	189	835	953
250M	2	406	349	-	168	261	250° ^{-0,5}	24	80	485	485	375	445	30	110	625	570	207	910	1028
	4-8	406	349	-	168	261	250° ^{-0,5}	24	80	485	485	375	445	30	120	625	570	207	910	1028
280S	2	457	368	-	190	295	280° ^{-1,0}	24	85	545	550	405	490	35	142	685	660	215	985	1103
	4-8	457	368	-	190	315	280° ^{-1,0}	24	85	545	550	405	490	35	142	685	660	215	1005	1153
280M	2	457	419	-	190	289	280° ^{-1,0}	24	85	545	550	405	540	35	142	685	660	215	1030	1148
	4-8	457	419	-	190	319	280° ^{-1,0}	24	85	545	550	405	540	35	142	685	660	215	1060	1208
315S	2	508	406	-	216	426	315° ^{-1,0}	28	120	630	625	560	570	45	110	875	780	257	1180	1328
	4-8	508	406	-	216	426	315° ^{-1,0}	28	120	630	625	560	570	45	110	875	780	257	1210	1358
315M 315L	2	508	457	508	216	485	315° ^{-1,0}	28	120	630	625	560	680	45	110	875	780	257	1290	1438
	4-8	508	457	508	216	485	315° ^{-1,0}	28	120	630	625	560	680	45	110	875	780	257	1320	1498
355M	2	610	500	560	254	640	355° ^{-1,0}	28	120	730	700	615	750	52	110	970	830	284	1526	1674
	4-8	610	500	560	254	640	355° ^{-1,0}	28	120	730	700	615	750	52	110	970	830	284	1556	1734
355L	2	610	560	630	254	580	355° ^{-1,0}	28	120	730	700	615	750	52	110	970	830	284	1526	1674
	4-8	610	560	630	254	580	355° ^{-1,0}	28	120	730	700	615	750	52	110	970	830	284	1556	1734
400M 400L	2	686	710	-	280	698	400° ^{-1,0}	35	120	810	860	-	1100	45	-	1090	-	362	1850	2028
	4-8	686	710	-	280	733	400° ^{-1,0}	35	120	810	860	-	1100	45	-	1090	-	362	1925	2143

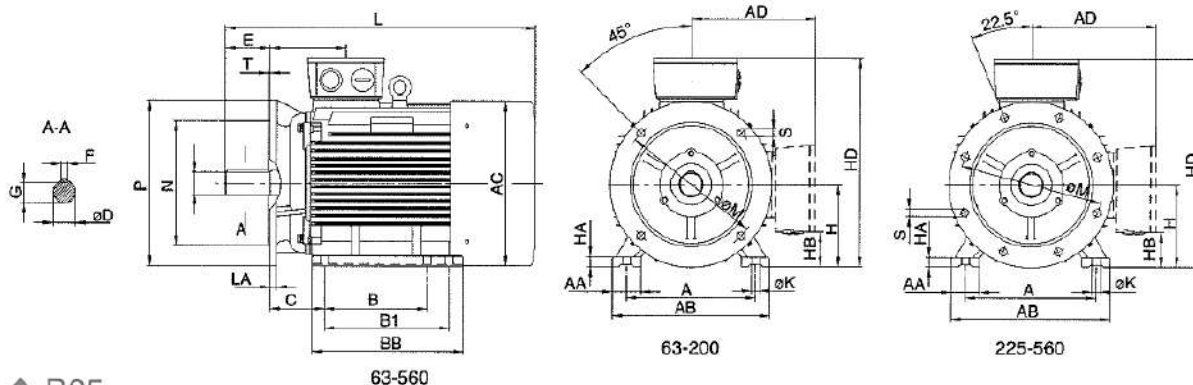

◆ B35

Frame	Poles	Dimension																	Dimension									
		A	B	B1	C	CA	H	K	M	N	P	R	S	T	AA	AB	AC	AD	BB	HA	HB	HD		LA	LD	L	LC	
		Top		L&R		Top		L&R		Top		L&R		Top		L&R		Top		L&R		Top		L&R		Top		L&R
60	2-8	125	100	-	50	96	80° -0.5	10	165	130	200	0	4-Ø12	4	33	160	160	145	130	12	36	225	160	12	75	290	336	
90S	2-8	140	100	-	56	117	90° -0.5	10	165	130	200	0	4-Ø12	4	36	180	180	155	140	12	30	245	180	12	75	315	373	
90L	2-8	140	125	-	56	117	90° -0.5	10	165	130	200	0	4-Ø12	4	36	180	180	155	165	12	50	245	180	12	75	340	373	
10CL	2-8	160	140	-	63	120	100° -0.5	12	215	180	250	0	4-Ø15	4	40	200	200	180	175	14	55	280	200	13	83	375	443	
112M	2-8	190	140	-	70	138	112° -0.5	12	215	180	250	0	4-Ø15	4	45	230	220	190	180	15	60	305	222	14	87	400	466	
132S	2-8	216	140	-	89	164	132° -0.5	12	265	230	300	0	4-Ø15	4	55	265	260	220	190	18	65	355	262	14	102	465	553	
132M	2-8	216	175	-	89	149	132° -0.5	12	265	230	300	0	4-Ø15	4	55	265	260	220	230	18	65	355	262	14	102	505	593	
160M	2-8	254	210	-	106	188	160° -0.5	13	300	250	350	0	4-Ø19	5	63	315	315	265	260	20	81	425	385	15	146	508	726	
16CL	2-8	254	254	-	106	188	160° -0.5	15	300	250	350	0	4-Ø19	5	65	315	315	265	305	20	81	425	385	15	146	652	770	
180M	2.4	279	241	-	121	225	180° -0.5	15	300	250	350	0	4-Ø19	5	70	350	350	280	315	22	105	450	420	15	161	690	806	
18CL	4-8	279	279	-	121	228	180° -0.5	15	300	250	350	0	4-Ø19	5	70	350	360	280	350	22	105	460	420	15	161	730	848	
200L	2-8	318	305	-	160	220	200° -0.5	19	350	300	400	0	4-Ø19	5	70	390	400	310	370	25	85	510	475	17	186	790	876	
225S	4-8	356	296	-	149	243	225° -0.5	19	400	350	450	0	4-Ø19	5	75	435	450	335	370	28	110	555	535	20	189	810	926	
225M	2	396	311	-	149	243	225° -0.5	19	400	350	450	0	4-Ø19	5	73	435	430	335	395	28	110	555	535	20	189	800	923	
250M	4-8	356	311	-	149	198	225° -0.5	19	400	350	450	0	4-Ø19	5	75	435	450	335	395	28	110	555	535	20	189	835	953	
250M	2	406	349	-	168	261	250° -0.5	24	500	450	550	0	4-Ø19	5	80	485	485	375	445	30	110	625	570	22	207	910	1028	
280S	4-8	406	349	-	168	261	250° -0.5	24	500	450	550	0	4-Ø19	5	80	485	485	375	445	30	120	625	570	22	207	910	1028	
280S	2	457	368	-	190	235	280° -1.0	24	500	450	550	0	4-Ø19	5	85	545	550	405	490	35	142	685	660	22	215	985	1103	
280S	4-8	457	368	-	190	315	280° -1.0	24	500	450	550	0	4-Ø19	5	85	545	550	405	490	35	142	685	660	22	215	1005	1153	
280M	2	497	419	-	190	289	280° -1.0	24	500	450	550	0	4-Ø19	5	83	545	530	405	540	35	142	685	660	22	215	1030	1148	
280M	4-8	457	419	-	190	319	280° -1.0	24	500	450	550	0	4-Ø19	5	85	545	550	405	540	35	142	685	660	22	215	1060	1208	
315S	2	508	406	-	216	426	315° -1.0	28	600	550	660	0	4-Ø24	6	120	630	625	560	570	45	110	875	780	22	257	1180	1328	
315S	4-8	508	406	-	216	426	315° -1.0	28	600	550	660	0	4-Ø24	6	120	630	625	560	570	45	110	875	780	22	257	1210	1358	
315M	2	508	457	508	216	495	315° -1.0	28	600	550	660	0	4-Ø24	6	120	630	625	560	680	45	110	975	780	22	257	1290	1498	
315L	4-8	508	457	508	216	495	315° -1.0	28	600	550	660	0	4-Ø24	6	120	630	625	560	680	45	110	975	780	22	257	1320	1498	
355M	2	610	500	560	254	640	355° -1.0	28	740	680	800	0	4-Ø24	6	120	730	700	615	750	52	125	970	830	25	284	1526	1674	
355M	4-8	610	500	560	254	640	355° -1.0	28	740	680	800	0	4-Ø24	6	120	730	700	615	750	52	125	970	830	25	284	1556	1734	
355L	2	610	560	630	254	590	355° -1.0	28	740	680	800	0	4-Ø24	6	120	730	700	615	750	52	125	970	890	25	284	1526	1674	
355L	4-8	610	560	630	254	590	355° -1.0	28	740	680	800	0	4-Ø24	6	120	730	700	615	750	52	125	970	890	25	284	1556	1674	
400M	2	686	710	-	260	695	400° -1.0	35	940	880	1000	0	4-Ø28	6	120	810	860	-	1100	45	-	1090	-	25	362	1650	2028	
400L	4-8	686	710	-	280	733	400° -1.0	35	940	880	1000	0	4-Ø28	6	120	810	860	-	1100	45	-	1090	-	25	362	1825	2143	

R= distance from flange to shaft shoulder.

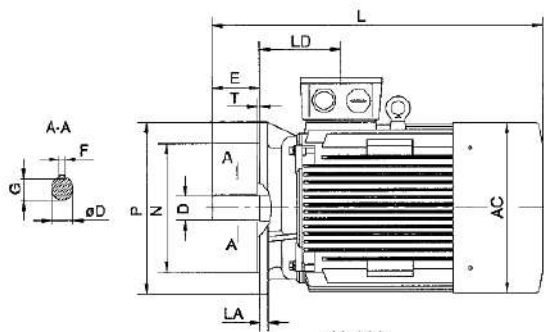

63-280

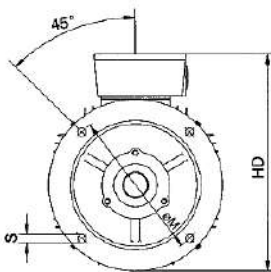

63-200

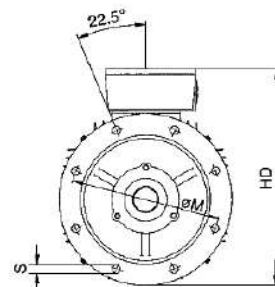

225-280

◆ B5

Frame	Pole	Dimension						Dimension					
		M	N	P	R	S	T	AC	AD	LA	LD	L	LG
80	2-8	165	130	200	0	4-ø12	4	160	145	12	75	280	336
90S	2-8	165	130	200	0	4-ø12	4	180	155	12	75	315	373
90L	2-8	165	130	200	0	4-ø12	4	180	155	12	75	340	373
100L	2-8	215	180	250	0	4-ø15	4	200	180	13	83	375	443
112M	2-8	215	180	250	0	4-ø15	4	220	193	14	87	400	468
132S	2-8	265	230	300	0	4-ø15	4	260	223	14	102	465	553
132M	2-8	265	230	300	0	4-ø15	4	260	223	14	102	505	593
160M	2-8	300	250	350	0	4-ø19	5	315	265	15	146	608	726
160L	2-8	300	250	350	0	4-ø19	5	315	265	15	146	652	770
180M	2.4	300	250	350	0	4-ø19	5	360	280	15	161	690	808
180L	4-8	300	250	350	0	4-ø19	5	360	280	15	161	730	848
200L	2-8	350	300	400	0	4-ø19	5	400	310	17	186	760	878
225S	4-8	400	350	450	0	4-ø19	5	450	330	20	189	810	928
225M	2	400	350	450	0	4-ø19	5	450	330	20	189	805	923
	4-8	400	350	450	0	4-ø19	5	450	330	20	189	835	953
250M	2	500	450	550	0	4-ø19	5	485	375	22	207	910	1028
	4-8	500	450	550	0	4-ø19	5	485	375	22	207	910	1028
280S	2	500	450	550	0	4-ø19	5	550	405	22	215	985	1103
	4-8	500	450	550	0	4-ø19	5	550	405	22	215	1005	1153
280M	2	500	450	550	0	4-ø19	5	550	405	22	215	1030	1148
	4-8	500	450	550	0	4-ø19	5	550	405	22	215	1060	1208

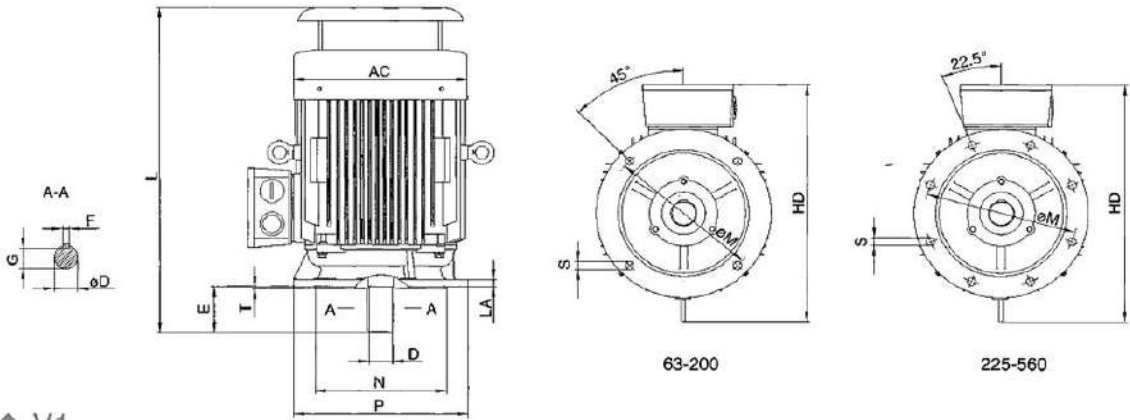

◆ V1

Frame	Pole	Dimension										Dimension				
		D	E	F	G	M	N	P	R	S	T	AC	HD	LA	LD	L
80	2-8	19	40	6	15.5	165	130	200	0	4-ø12	4	160	225	12	75	305
90S	2-8	24	50	8	20	165	130	200	0	4-ø12	4	180	245	12	75	345
90L	2-8	24	50	8	20	165	130	200	0	4-ø12	4	180	245	12	75	370
100L	2-8	28	60	8	24	215	180	250	0	4-ø15	4	200	280	13	83	410
112M	2-8	28	60	8	24	215	180	250	0	4-ø15	4	220	305	14	87	450
132S	2-8	38	80	10	33	265	230	300	0	4-ø15	4	260	365	14	102	510
132M	2-8	38	80	10	33	265	230	300	0	4-ø15	4	260	365	14	102	550
160M	2-8	42	110	12	37	300	250	350	0	4-ø19	5	315	445	15	146	660
160L	2-8	42	110	12	37	300	250	350	0	4-ø19	5	315	445	15	146	705
180M	2.4	48	110	14	42.5	300	250	350	0	4-ø19	5	360	480	15	161	750
180L	4-8	48	110	14	42.5	300	250	350	0	4-ø19	5	360	480	15	161	790
200L	2-8	55	110	16	49	350	300	400	0	4-ø19	5	400	530	17	186	840
225S	4-8	60	140	18	53	400	350	450	0	4-ø19	5	450	575	20	189	905
225M	2	55	110	16	49	400	350	450	0	4-ø19	5	450	575	20	189	910
	4-8	60	140	18	53	400	350	450	0	4-ø19	5	450	575	20	189	935
250M	2	60	140	18	53	500	450	550	0	4-ø19	5	485	635	22	207	1005
	4-8	65	140	18	58	500	450	550	0	4-ø19	5	485	635	22	207	1005
280S	2	65	140	18	58	500	450	550	0	4-ø19	5	550	725	22	215	1110
	4-8	75	140	20	67.5	500	450	550	0	4-ø19	5	550	725	22	215	1130
280M	2	65	140	18	58	500	450	550	0	4-ø19	5	550	725	22	215	1155
	4-8	75	140	20	67.5	500	450	550	0	4-ø19	5	550	725	22	215	1185
315S	2	65	140	18	58	600	550	660	0	4-ø24	6	625	895	22	257	1340
	4-8	80	170	22	71	600	550	660	0	4-ø24	6	625	895	22	257	1370
315M	2	65	140	18	58	600	550	660	0	4-ø24	6	625	895	22	257	1450
315L	4-8	80	170	22	71	600	550	660	0	4-ø24	6	625	895	22	257	1480
355M	2	75	140	20	67.5	740	680	800	0	4-ø24	6	700	970	25	284	1665
355L	4-8	100	210	25	86	740	680	800	0	4-ø24	6	700	970	25	284	1700
400M	2	80	170	22	71	940	880	1000	0	4-ø28	6	860	1150	25	362	2150
400L	4-8	110	210	28	100	940	880	1000	0	4-ø28	6	860	1150	25	362	2220



CONTACTS

Head Quarter

FELM srl

Via Morandi (Industrial Area)

20010 Inveruno (Mi) Italy

Tel. +39 02 97 289 454

Tel. +39 02 97 288 320

Fax +39 02 97 289 923

E-mail home@felm.it

FELM Office Middle East

Jebel Ali Free Zone, Warehouse no. FZS1-BM07,

PO Box 263632, Dubai, United Arab Emirates

Office Ph. +971 (04) 887 9767

mobile +971 50 550 1322

Email: ayman.abdallah@felm.it

FELM Office Germany

Heinrich-Busold-Strasse 47

D-61169 Friedberg (Hessen), Germany

Tel (Off): +49-6031-721606

Mobile: +49-172-6729011

Fax: +49-6031-721610

Email: Jayant@jk-conrep.de

FELM Office China

Add: Room 1002, Building 3#,

No 139 Rd. SongShan,

Jianye, Nanjing, Jiangsu, China

Fax: +86-25-87797622

Tel: +86-15077829999

Email: lidongming1974@vip.sina.com

FELM Office UK

The Foundry, Wadebridge

Cornwall, PL27 7JP

United Kingdom

Tel (Off): +441208 816543

Email: sales@felm.co.uk

WORLD WIDE SERVICE

Mobile +39 355 69 53 804

E-mail service@felm.it





RollerTable Motors

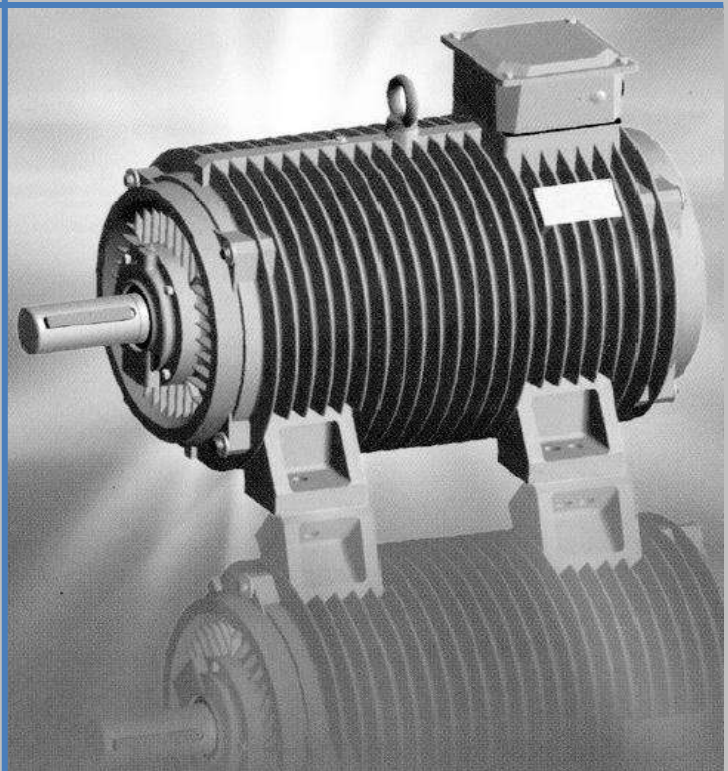

■ General

YGP series roller table motors (Hereafter refers to as YGP motors) are special driving elements for the development of steel industry, can be used with many kinds of SPWM frequency conversion installment. This kind of motor is suitable for continuous operation in high temperature, moist and dusty environment, it has advantage of small volume, light weight, low vibration, high reliability, high overload capacity, beautiful appearance, wide speed adjusting range, firm structure, easy maintenance, and ect.

YGP motor can be continuous or intermittent operation in the condition of frequent starting, brake, both rotation and over torque, 10% voltage compensation is permitted when motor operate in low frequency, and can produce big enough starting torque to meet overload starting, frame size 200 and above motors are suitable for re-greasing during operation, which can prolong the maintenance term, improve the working efficiency, heat protector, space heater, encoder, electromagnetic brake can be mounted in order to meet the customer requirement.

The insulation class of YGP motor is class F or H, protection class is IP55, IP56, IP65 are also suitable according to the customer requirement; the cooling type is IC410; mounting type is IMB3 (frame size 112-400), IMB5 (frame size 112-250), IMB35 (frame size 112-250), the rated voltage is 380V, rated frequency is 50HZ, frequency range 5-50HZ is constant torque, 50-100HP is constant output, frequency range can be set according to the required speed range for the customer, then special roller table motors can be designed.

YGP motor type meanings

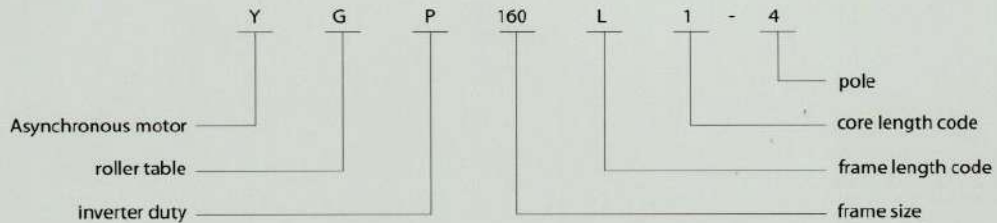

■ Application

YGP motors are suitable for rolling mill industry, particularly in case of working and conveying roller table, also suitable for other similar mechanical equipment.

YGP motor can be direct coupling with rotating roller, by selecting the pole and frequency adjusting, can make the roller table motor to be wide range infinitely variable speed with any other mechanical speed reducing equipment such as gear box and ect. Every roller table conveying equipment using numbers of roller table motors, roller table motors and frequency converter using together, and speed can be controlled through frequency converter.

YGP motors are suitable for all kinds of duty cycle, for intermittent duty the base duty cycle is S5, load continuous rate is 60%, starting 300 times per hour.

■ Technical performance data

● 380V ,50Hz Rated Voltage 380V Rated frequency 50Hz

Frame	Poles	Output kW	Rated Torque N.m	Breakdown Torque (time)	Rated current A	Maximum Current A	Moment of inertia kg.m ²	Weight kg
112L	4	2	12.7	2.5	4.38	11.2	0.0166	75
132M1	4	3	19.1	2.5	6.01	16.5	0.0251	85
132M2	4	4	25.5	2.5	8.41	20.4	0.0333	95
160S	4	5.5	35.0	2.5	10.71	28.3	0.1140	160
160L1	4	7.5	47.8	2.5	14.94	36.2	0.1140	180
160L2	4	11	70.0	2.5	21.85	51.9	0.1400	190
180L	4	15	95.5	3.0	29.24	82.0	0.294	240
200L1	4	18.5	117.8	3.0	35.43	101	0.566	295
200L2	4	22	140	3.0	41.69	119	0.632	315
225M	4	30	191	3.0	55.14	160	1.10	470
250M1	4	37	235	3.0	68.09	197	2.57	572
250M2	4	45	286	3.0	84.22	236	2.57	617
280L1	4	55	350	3.0	102.2	283	5.12	750
280L2	4	75	477	3.0	131.0	387	6.95	800
315S	4	90	573	3.0	154.7	465	9.6	1080
315M1	4	110	700	3.0	189.6	561	11.4	1200
315M2	4	132	840	3.0	226.7	672	12.5	1290
112L	6	1.1	10.5	2.5	3.05	6.5	0.0166	75
132M1	6	2	19.1	2.5	5.29	10.7	0.0251	95
132M2	6	3	28.7	2.5	7.61	15.7	0.0333	105
160S	6	4	38.2	2.5	9.54	20.9	0.114	165
160L1	6	5.5	52.5	2.5	12.60	28.5	0.114	200
160L2	6	7.5	71.6	2.5	16.92	38.3	0.14	210
180L	6	11	105.1	2.5	24.23	51.8	0.294	235
200L1	6	15	143.3	3.0	31.99	85.0	0.566	310
200L2	6	18.5	176.7	3.0	39.78	104	0.632	345
225M	6	22	210.1	3.0	41.47	128.8	1.10	445
250M1	6	25	238.8	3.0	48.11	135.9	2.57	563
250M2	6	30	286.5	3.0	57.28	162.7	2.57	599

● 380V . 50Hz Rated Voltage 380V Rated frequency 50Hz

Frame	Poles	Output kW	Rated Torque N.m	Breakdown Torque (time)	Rated current A	Maximum Current A	Moment of inertia kg.m ²	Weight kg
280L1	6	37	353.4	3.0	73.57	196.0	5.12	750
280L2	6	45	429.8	3.0	84.41	240.1	6.95	800
315S1	6	55	525.3	3.0	98.51	314.8	9.60	1000
315M1	6	75	716.3	3.0	133.54	423.9	11.4	1130
315M2	6	90	859.5	3.0	160.20	501.9	12.5	1230
355L1	6	110	1050.5	3.0	194.96	595.0	18.6	1650
355L2	6	132	1260.6	3.0	235.37	707.4	22.2	1760
355L3	6	160	1528.0	3.0	283.74	856.5	25.6	1850
400L1	6	185	1766.8	3.0	352.97	1018.6	37.1	2360
400L2	6	200	1910.0	3.0	364.96	1150.0	42.6	2460
400L3	6	220	2101.0	3.0	406.76	1235.1	51.7	2560
180L	8	7.5	95.5	2.5	18.37	39.9	0.294	225
200L1	8	11	140	2.5	26.89	55.7	0.566	310
200L2	8	13	165.5	3.0	30.22	82.9	0.632	325
225M	8	15	191.0	3.0	32.53	99.2	1.10	435
250M1	8	18.5	235.6	3.0	39.82	111.3	2.57	563
250M2	8	22	280.1	3.0	48.05	129.9	2.57	595
280L1	8	30	382.0	3.0	68.39	167.9	5.12	750
280L2	8	37	471.1	3.0	80.64	207.4	6.95	800
315S1	8	45	573.0	3.0	87.00	248.9	9.60	1000
315M1	8	55	700.3	3.0	108.00	303.5	11.4	1070
315M2	8	75	955.0	3.0	151.3	403.9	12.5	1230
355L1	8	90	1146.0	3.0	163.27	513.6	18.6	1600
355L2	8	110	1400.7	3.0	198.08	627.8	22.2	1690
355L3	8	132	1680.8	3.0	239.04	783.1	25.6	1780
400L1	8	160	2037.3	3.0	315.99	1097.7	37.1	2450
400L2	8	185	2355.7	3.0	372.61	1155.3	42.6	2580
400L3	8	200	2546.7	3.0	434.34	1155.8	51.7	2730

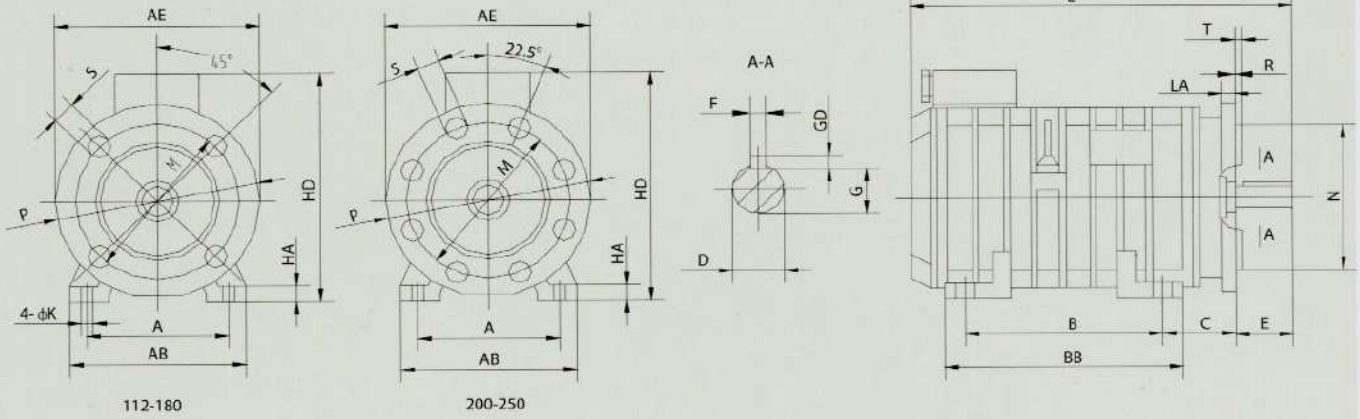

● B35 Table 2 (with foot and flange)

		Mounting dimensions and tolerance																			
Frame		A	B	C	D	E	F	G	GD	H	K	M	N	P	R ¹⁾	S	T				
112L	FF215	190	159	70	32			27	8	112											
				± 2.0		80	± 0.37	10	0		12	± 0.43	215	180	+0.014	250	± 2.0	15	+0.43	4.0	
132M	FF265	216	178	89	38	+0.018		-0.036	33	8	132		265	230		300					
160S					+0.002																
160L	FF300	254	254	108	48		110	± 0.43	14	0	15	42.5	9	160	300	250	+0.016	350	+3.0		
				± 3.0					0	0							0			4	
180L		279	279	121	55			16	49	-0.2	10	180	-0.5								
200L		318	305	133	65	+0.030		18	58												
	FF400				+0.011	140					19	200		400	350	± 0.018	450		19	+0.52	5.0
225M		356	311	149	75		± 0.50	20	0												8
				± 4.0					-0.052												
250M	FF500	406	349	168	80		170	22	71		24	250		500	450	± 0.02	550				

		Outline dimensions						
Frame		AB	AE	BB	LA	HA	HD	L
112L		235	250	200	12	20	330	460
132M		265	300	236	12	23	355	520
160S								650
160L		315	350	310	14	25	410	700
180L		360	360	350	16	30	500	750
200L		415	450	400	18	35	570	860
225M		470	470	415	18	35	620	950
250M		510	550	450	22	40	680	990

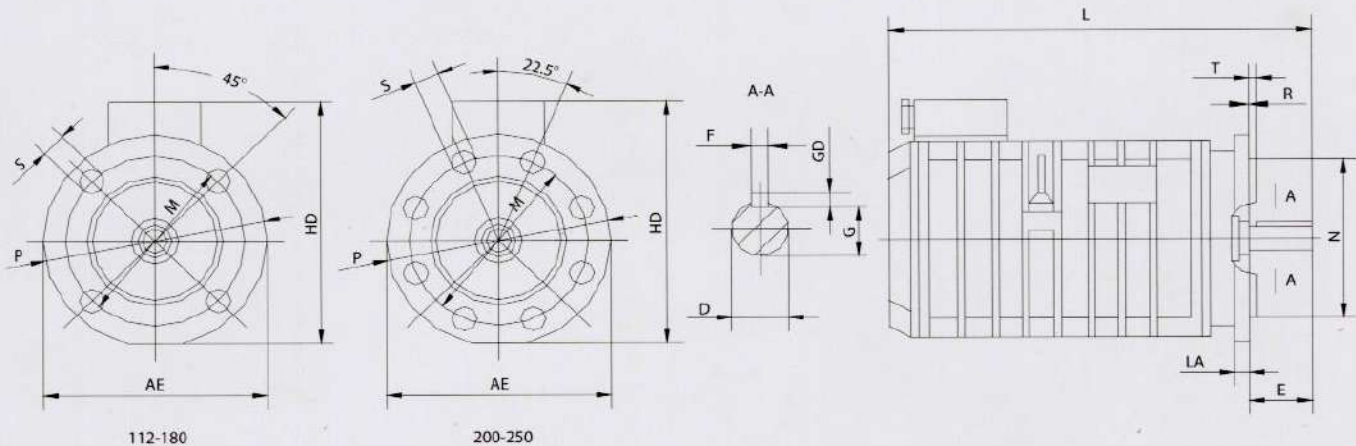

● B5 Table 3 B5 (without foot, with flange)

Frame	Flange No	Mounting dimensions and tolerance											Outline dimensions														
		D	E	F	G	GD	M	N	P	R ¹⁾	S	T	AE	HD	LA	L											
112L	FF215	32			0	27				215	180	+0.014 -0.010	250				250	330	12	460							
132M	FF265	38	+0.018 +0.002	80 ±0.37	10	-0.036	33		8	265	230		300		±2.0	15	+0.43 0	4.0		300	355	12	520				
160S					14		42.5		9			+0.016 -0.013							4					650			
160L	FF300	48		110		0			0	300	250		350		±3.0									700			
180L		55			±0.43	0			0															360	500	16	750
200L		65	+0.030 +0.011			18		58	11								19	+0.52 0	5.0					450	570	18	860
225M	FF400	75		140		±0.50	20	0	67.5	12														470	620	18	950
250M	FF500	80					-0.052	71	14	500	450	±0.02	550							8				550	630	22	990

Remark: 1) R is distance from flange to shaft shoulder.

■ Ordering information

- ◆ Please specify the motor type, output, rated voltage, rated frequency, poles (or rated speed), frequency range, mounting type, duty cycle and ect.
- ◆ If no special indication, normally the terminal box is on the top of the motor, cable entry facing the non driving end, and customer can specify the orientation of the cable entry.
- ◆ Any special requirement please specify when in enquiry.
- ◆ The technical data in the catalogue is only for reference, and may not inform you immediately.

All data listed in the tables are indicative and not binding. The guaranteed values are upon request. Felm srl reserves the right to change the project, the technical characteristics and dimensions at any time without previous notice.



CONTACTS

Head Quarter

FELM srl

Via Morandi (Industrial Area)

20010 Inveruno (Mi) Italy

Tel. +39 02 97 289 454

Tel. +39 02 97 288 320

Fax +39 02 97 289 923

E-mail home@felm.it



FELM Office Germany

Heinrich-Busold-Strasse 47

D-61169 Fridberg (Hessen), Germany

Tel. (Off.) +49 6331 721606

Mobile +49 172 6729011

E-mail Jayant@jk-conrep.de

FELM Office China

Room 1002, Building 3#, No.139 Rd. SongShan

Jianye, Nanjing, Jiangsu, China

Te. +86 150 778 29 999

Fax +86 25 87 797 622

E-mail lidongming1974@vip.sina.com

FELM Office Middle East

Al Saalam Street, Al Darwish Building (NBAD building)

office no. 1403 Abu Dhabi (United Arab Emirates)

P.O. Box 45223

Office Ph. + 971-2-6710330

Office Fax + 971-2-6710255

mobile +971 50 4442093

WORLD WIDE SERVICE

Mobile +39 355 69 53 804

E-mail service@felm.it



ISO 14001



BUREAU
VERITAS

Certificate
EAC - CUTR EurAseC
(Russian Market)



Open Drip Proof Motors



IP23



Available IE2 IE3

SPECIFICHE TECNICHE (50HZ) 2 POLI
TECHNICAL SPECIFICATION (50HZ) 2 POLE

Motor Type	Rated output KW	Full load					Locked Current	Locked Torque	Break-down Torque	moment of inertia J	weight
		Current A		Speed r/min	Power factor COSØ	Efficiency η%					
		380V	400V				Rated Current	Rated Torque	Rated Torque	kgm ²	kg
Y ₂ -ODP 160M2	15	28.9	27.5	2920	0.88	89.5	6.5	2.0	2.5	0.067	132
Y ₂ -ODP 160L2	18.5	35.1	33.3	2925	0.88	91.0	6.8	2.1	2.6	0.068	141
Y ₂ -ODP 160LX2	22	43.6	41.4	2925	0.87	88.2	7.0	2.1	2.6	0.070	152
Y ₂ -ODP 180M2	30	56.6	53.7	2935	0.89	90.8	7.0	2.2	2.8	0.125	210
Y ₂ -ODP 180L2	37	69.3	65.8	2940	0.89	91.2	7.0	2.2	2.8	0.135	222
Y ₂ -ODP 200M2	45	83.7	79.5	2945	0.89	91.8	7.0	2.1	2.7	0.188	285
Y ₂ -ODP 200L2	55	102	97.3	2945	0.89	91.7	7.0	2.1	2.7	0.210	297
Y ₂ -ODP 225M2	75	138	131	2950	0.89	92.5	7.2	2.1	2.8	0.362	367
Y ₂ -ODP 250S2	90	163	154	2960	0.90	93.5	7.5	2.4	3.0	0.531	507
Y ₂ -ODP 250M2	110	197	187	2965	0.90	94.5	7.5	2.4	3.0	0.584	543
Y ₂ -ODP 280M2	132	234	223	2960	0.91	94.0	7.5	2.2	3.0	0.793	700
Y ₂ -ODP 315S2(A)	160	289	275	2970	0.89	94.4	6.5	1.6	2.8	1.592	942
Y ₂ -ODP 315M2(A)	200	371	352	2965	0.87	94.2	7.2	1.6	2.8	1.751	970
Y ₂ -ODP 315LA2(A)	250	463	439	2965	0.87	94.4	7.2	1.6	2.8	1.935	1035
Y ₂ -ODP 315LB2(A)	280	495	471	2970	0.90	95.4	7.0	1.8	2.8	2.177	1084
Y ₂ -ODP 315LX2(A)	315	556	528	2970	0.90	95.6	7.0	1.9	3.0	2.503	1180
Y ₂ -ODP 315LY2(B)	355	649	617	2965	0.87	95.5	7.0	1.5	2.1	2.629	1286
Y ₂ -ODP 315LZA2(B)	400	696	662	2970	0.91	95.9	7.0	1.8	3.0	2.997	1350
Y ₂ -ODP 315LZB2(B)	450	823	782	2970	0.87	95.5	7.0	1.5	2.1	3.145	1420
Y ₂ -ODP 355M2	500	860	817	2970	0.92	96.0	6.5	1.3	2.7	4.500	1620
Y ₂ -ODP 355MX2	560	963	915	2970	0.92	96.0	6.5	1.3	2.7	4.870	1730
Y ₂ -ODP 355L2	630	1084	1030	2970	0.92	96.0	6.5	1.3	2.7	5.340	1855
Y ₂ -ODP 355LX2	710	1221	1160	2970	0.92	96.0	6.5	1.3	2.7	5.340	1880

SPECIFICHE TECNICHE (50HZ) 4 POLI
 TECHNICAL SPECIFICATION (50HZ) 4 POLE

Motor Type	Rated output KW	Full load					Locked Current	Locked Torque	Break-down Torque	moment of inertia J	weight
		Current A		Speed r/min	Power factor COSØ	Efficiency η%					
		380V	400V				Rated Current	Rated Torque	Rated Torque	kgm²	kg
Y ₂ -ODP 160M4	11	22.7	21.6	1450	0.83	88.7	6.0	1.8	2.3	0.122	140
Y ₂ -ODP 160L4	15	30.2	28.7	1460	0.84	89.8	6.5	2.0	2.5	0.128	142
Y ₂ -ODP 160LX4	18.5	36.8	35.0	1460	0.84	90.9	7.0	2.2	2.5	0.130	154
Y ₂ -ODP 180M4	22	41.6	39.6	1460	0.88	91.2	7.5	2.7	3.2	0.224	206
Y ₂ -ODP 180L4	30	59.0	53.5	1460	0.88	91.9	7.5	2.7	3.2	0.266	226
Y ₂ -ODP 200M4	37	71.3	67.7	1465	0.86	91.7	6.5	2.1	2.6	0.328	297
Y ₂ -ODP 200L4	45	86.4	82.1	1465	0.86	92.0	6.5	2.1	2.6	0.620	311
Y ₂ -ODP 225M4	55	102	97.0	1470	0.88	93.0	7.0	2.4	3.0	0.945	389
Y ₂ -ODP 250S4	75	139	132	1475	0.88	93.1	7.0	2.4	3.0	1.032	524
Y ₂ -ODP 250M4	90	164	156	1475	0.89	93.5	7.2	2.4	3.0	1.546	551
Y ₂ -ODP 280S4	110	197	187	1475	0.90	94.4	7.4	2.6	3.2	1.764	735
Y ₂ -ODP 280M4	132	238	226	1475	0.90	93.5	7.0	2.4	3.0	3.212	742
Y ₂ -ODP 315S4(A)	160	295	280	1480	0.87	94.8	6.2	1.7	2.5	3.074	968
Y ₂ -ODP 315M4(A)	200	367	349	1480	0.87	95.2	6.2	1.7	2.5	3.744	1064
Y ₂ -ODP 315LA4(A)	250	453	430	1480	0.88	95.3	6.2	1.7	2.5	4.481	1165
Y ₂ -ODP 315LB4(A)	280	512	486	1475	0.87	95.6	6.0	1.6	2.4	4.446	1205
Y ₂ -ODP 315LX4(B)	315	567	539	1480	0.88	95.9	6.5	1.8	2.6	5.126	1364
Y ₂ -ODP 315LY4(B)	355	646	614	1480	0.87	96.0	7.0	1.9	2.8	6.090	1498
Y ₂ -ODP 315LZB4(B)	400	748	710	1480	0.86	94.5	6.7	1.6	2.4	6.211	1506
Y ₂ -ODP 355S4	450	827	786	1485	0.87	95.0	6.0	1.4	2.3	8.480	1750
Y ₂ -ODP 355M4	500	914	869	1485	0.87	95.5	6.0	1.4	2.3	9.170	1790
Y ₂ -ODP 355MX4	560	1012	962	1485	0.88	95.5	6.0	1.4	2.3	10.49	1945
Y ₂ -ODP 355L4	630	1145	1088	1485	0.88	95.0	6.5	1.6	2.5	12.08	2095
Y ₂ -ODP 355LX4	710	1277	1213	1485	0.88	96.0	6.5	1.6	2.5	12.08	2130

SPECIFICHE TECNICHE (50HZ) 6 POLI
TECHNICAL SPECIFICATION (50HZ) 6 POLE

Motor Type	Rated output KW	Full load					Locked Current	Locked Torque	Break-down Torque	moment of inertia J	weight
		Current A		Speed r/min	Power factor COSØ	Efficiency η%					
		380V	400V				Rated Current	Rated Torque	Rated Torque	kgm²	kg
Y ₂ -ODP 160LX6	11	24.7	23.4	975	0.77	88.0	6.0	1.8	2.5	0.162	141
Y ₂ -ODP 180M6	15	31.6	30.0	975	0.81	89.0	6.0	2.3	2.8	0.231	198
Y ₂ -ODP 180L6	18.5	38.1	36.2	975	0.82	90.0	6.0	2.3	2.8	0.256	212
Y ₂ -ODP 200M6	22	44.9	42.7	980	0.82	90.7	6.5	2.1	2.7	0.342	262
Y ₂ -ODP 200L6	30	61.0	57.9	980	0.82	91.2	6.5	2.1	2.7	0.402	279
Y ₂ -ODP 225M6	37	71.4	67.8	980	0.86	91.6	6.5	2.1	2.7	0.632	343
Y ₂ -ODP 250S6	45	88.9	84.4	985	0.84	91.6	6.5	2.2	2.8	0.834	473
Y ₂ -ODP 250M6	55	108	103	985	0.84	91.8	6.5	2.2	2.8	0.894	490
Y ₂ -ODP 280S6	75	148	140	985	0.83	93.0	6.0	2.0	2.5	1.421	675
Y ₂ -ODP 280M6	90	174	165	985	0.84	93.6	6.0	2.0	2.5	1.853	745
Y ₂ -ODP 315S6(A)	110	216	206	988	0.82	94.2	5.5	1.6	2.4	3.378	925
Y ₂ -ODP 315M6(A)	132	259	246	988	0.82	94.6	5.5	1.7	2.4	3.961	965
Y ₂ -ODP 315MX6(A)	160	316	300	988	0.81	95.0	6.0	1.8	2.5	4.804	1083
Y ₂ -ODP 315LA6(A)	180	351	334	988	0.82	95.0	6.0	1.8	2.5	5.187	1127
Y ₂ -ODP 315LB6(A)	200	385	366	988	0.83	95.0	6.0	1.8	2.5	5.727	1165
Y ₂ -ODP 315LX6(B)	225	433	411	988	0.83	95.2	6.0	1.8	2.5	6.309	1335
Y ₂ -ODP 315LY6(B)	250	481	457	988	0.83	95.2	6.0	1.9	2.5	7.022	1371
Y ₂ -ODP 315LZB6(B)	280	538	511	988	0.83	95.2	6.0	1.9	2.5	7.888	1462
Y ₂ -ODP 355S6	315	618	587	988	0.82	94.5	5.0	1.5	1.9	7.910	1620
Y ₂ -ODP 355M6	355	692	658	988	0.82	95.0	5.3	1.6	2.0	9.330	1730
Y ₂ -ODP 355MX6	400	780	741	988	0.82	95.0	5.5	1.6	2.0	9.330	1770
Y ₂ -ODP 355MY6	450	878	834	988	0.82	95.0	5.5	1.6	2.0	10.74	1925
Y ₂ -ODP 355L6	500	970	922	988	0.82	95.5	6.0	1.7	2.2	12.25	2075

SPECIFICHE TECNICHE (50HZ) 8 POLI
 TECHNICAL SPECIFICATION (50HZ) 8 POLE

Motor Type	Rated output KW	Full load					Locked Current	Locked Torque	Break-down Torque	moment of inertia J kgm ²	weight kg
		Current A		Speed r/min	Power factor COSØ	Efficiency η%	Rated Current	Rated Torque	Rated Torque		
		380V	400V								
Y ₂ -ODP 180M8	11	26	25	715	0.76	84.0	4.5	1.8	2.1	0.220	185
Y ₂ -ODP 180L8	15	35	33	715	0.77	84.5	4.5	1.8	2.1	0.260	200
Y ₂ -ODP 200M8	18.5	43	41	720	0.77	84.5	4.5	1.8	2.1	0.340	240
Y ₂ -ODP 200L8	22	50	48	720	0.77	86.0	4.5	1.8	2.1	0.370	250
Y ₂ -ODP 225M8	30	67	64	725	0.77	88.0	4.8	1.8	2.2	0.640	355
Y ₂ -ODP 250S8	37	83	79	730	0.77	88.0	4.8	1.8	2.2	0.850	420
Y ₂ -ODP 250M8	45	101	96	730	0.77	88.0	4.8	1.8	2.2	0.920	440
Y ₂ -ODP 280S8	55	120	114	730	0.77	90.5	5.5	2.0	2.5	1.800	645
Y ₂ -ODP 280M8	75	164	155	730	0.77	90.5	5.5	2.0	2.5	1.800	645
Y ₂ -ODP 315S8	90	188	179	735	0.79	92.0	6.0	1.7	3.0	3.956	870
Y ₂ -ODP 315M8	110	226	215	735	0.8	92.5	6.0	1.7	3.0	5.125	955
Y ₂ -ODP 315MX8	132	271	257	735	0.8	92.5	6.0	1.7	3.0	5.983	970
Y ₂ -ODP 315L8	160	313	298	735	0.83	93.5	5.8	1.3	2.3	6.865	1060
Y ₂ -ODP 315LX8	200	398	379	735	0.82	93.0	5.5	1.2	2.2	7.895	1110
Y ₂ -ODP 315LY8	225	446	424	735	0.82	93.5	5.8	1.3	2.3	8.354	1280
Y ₂ -ODP 355M8	250	525	499	742	0.77	94.0	5.0	1.4	2.0	9.540	1760
Y ₂ -ODP 355MX8	280	585	555	742	0.77	94.5	5.0	1.4	2.0	10.97	1925
Y ₂ -ODP 355L8	315	641	609	742	0.79	94.5	5.0	1.4	2.0	12.51	2080

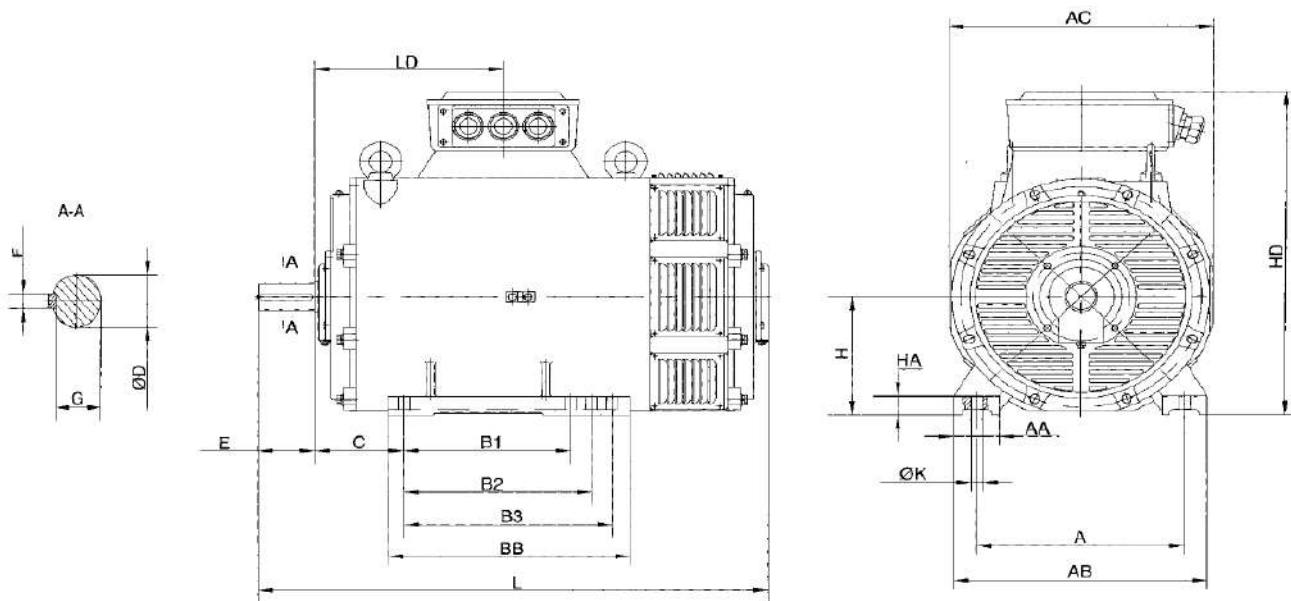

◆ B3

Frame size	Poles	Mounting dimensions (mm)											Overall dimensions (mm)							
		A	B1	B2	B3	C	D	E	F	G	H	K	AB	AC	HD	BB	LD	HA	AA	L
160M/L	2/4/6/8	254	210	254	/	108	48	110	14	42.5	160	14	294	305	430	306	228	24	45	700
180M/L	2/4/6/8	279	241	279	/	121	55	110	16	49	180	15	350	380	490	355	262	30	65	760
200M/L	2/4/6/8	318	267	305	/	133	60	140	18	53	200	19	392	445	550	375	287	30	70	805
225M	2	356	311	/	/	149	60	140	18	53	225	19	445	475	630	387	318	35	75	885
225M	4/6/8	356	311	/	/	149	65	140	18	58	225	19	445	475	630	387	318	35	75	885
250S/M	2	406	311	349	/	168	65	140	18	58	250	24	492	520	730	425	332	40	85	960
250S/M	4/6/8	406	311	349	/	168	75	140	20	67.5	250	24	492	520	730	425	332	40	85	960
280S/M	2	457	368	419	/	190	65	140	18	58	280	24	555	585	785	490	369	45	95	1060
280S/M	4/6/8	457	368	419	/	190	80	170	22	71	280	24	555	585	785	490	369	45	95	1090
315(A)	2	508	406	457	508	216	70	140	20	62.5	315	28	620	665	875	615	473	50	110	1260
315(A)	4/6/8	508	406	457	508	216	90	170	25	81	315	28	620	665	875	615	473	50	110	1295
315(B)	2	508	457	508	560	216	80	140	22	71	315	28	620	665	875	800	473	50	110	1455
315(B)	4/6/8	508	457	508	560	216	90	170	25	81	315	28	620	665	875	800	473	50	110	1490
355M/L	2	610	500	560	630	254	80	170	22	71	355	24	740	768	1085	760	569	55	120	1628
355M/L	4/6/8	610	500	560	630	254	100	210	28	90	355	24	740	768	1085	760	569	55	120	1670

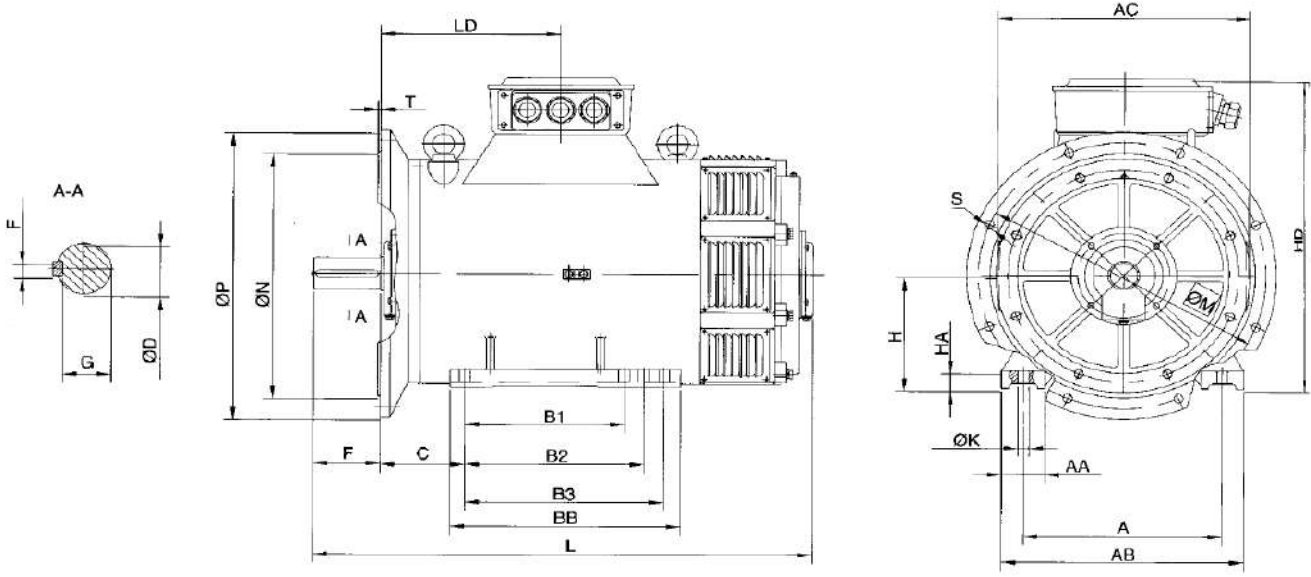

◆ B35

Frame size	Poles	Mounting dimensions (mm)																Overall dimensions (mm)			
		A	B1	B2	B3	C	D	E	F	G	H	K	M	N	P	S	T	AB	AC	HD	L
160M/L	2/4/6/8	254	210	254	/	108	48	110	14	42.5	160	14	300	250	350	4-19	5	294	305	430	700
180M/L	2/4/6/8	279	241	279	/	121	55	110	16	49	180	15	350	300	400	4-19	5	350	380	490	760
200M/L	2/4/6/8	318	267	305	/	133	60	140	18	53	200	19	400	350	450	8-19	5	392	445	550	805
225M	2	356	311	/	/	149	60	140	18	53	225	19	500	450	550	8-19	5	445	475	630	885
225M	4/6/8	356	311	/	/	149	65	140	18	58	225	19	500	450	550	8-19	5	445	475	630	885
250S/M	2	406	311	349	/	168	65	140	18	58	250	24	600	550	660	8-24	6	492	520	730	690
250S/M	4/6/8	406	311	349	/	168	75	140	20	67.5	250	24	600	550	660	8-24	6	492	520	730	690
280S/M	2	457	368	419	/	190	65	140	18	58	280	24	600	550	660	8-24	6	555	585	785	1060
280S/M	4/6/8	457	368	419	/	190	80	170	22	71	280	24	600	550	660	8-24	6	555	585	785	1090
315(A)	2	508	406	457	508	216	70	140	20	62.5	315	28	740	680	800	8-24	6	620	665	875	1260
315(A)	4/6/8	508	406	457	508	216	90	170	25	81	315	28	740	680	800	8-24	6	620	665	875	1295
315(B)	2	508	457	508	560	216	80	140	22	71	315	28	740	680	800	8-24	6	620	665	875	1455
315(B)	4/6/8	508	457	508	560	216	90	170	25	81	315	28	740	680	800	8-24	6	620	665	875	1490
355M/L	2	610	500	560	630	254	80	170	22	71	355	24	940	880	1000	8-20	6	740	768	1085	1628
355M/L	4/6/8	610	500	560	630	254	100	210	28	90	355	24	940	880	1000	8-20	6	740	768	1085	1670

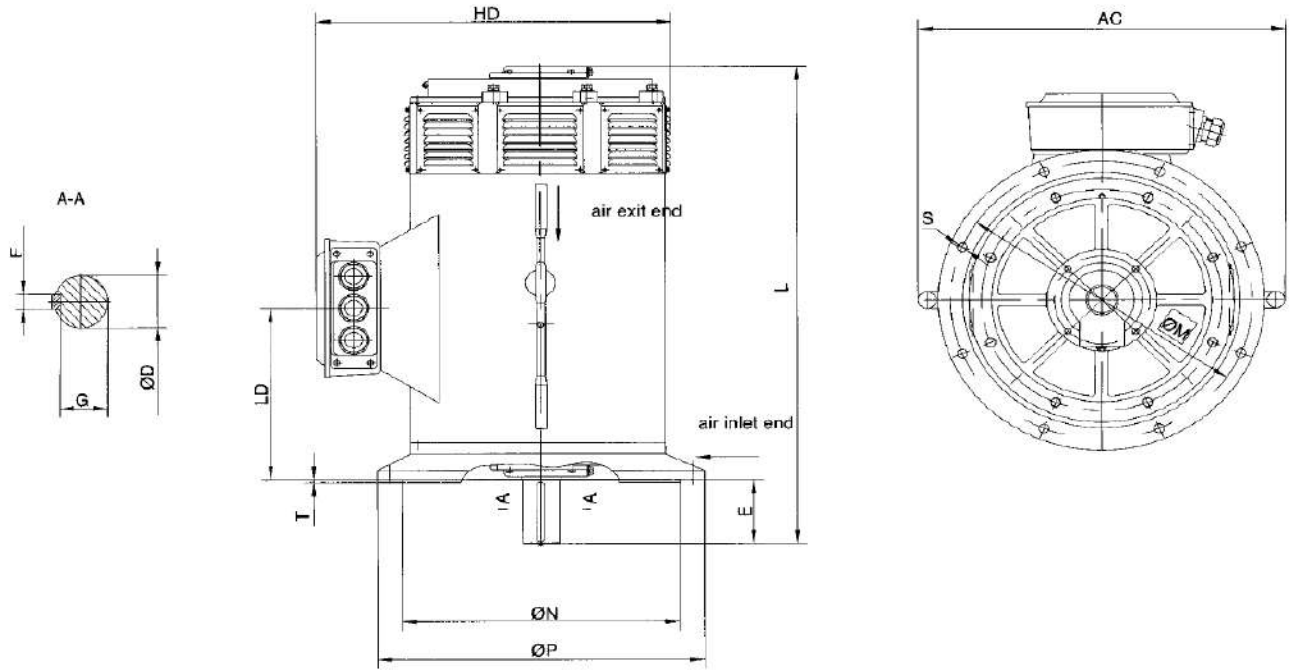

◆ B5(V1)

Frame size	Poles	Mounting dimensions (mm)										Overall dimensions (mm)		
		D	E	F	G	H	M	N	P	S	T	AC	HD	L
160M/L	2/4/6/8	48	110	14	42.5	160	300	250	350	4-19	5	425	430	700
180M/L	2/4/6/8	55	110	16	49	180	350	300	400	4-19	5	488	490	760
200M/L	2/4/6/8	60	140	18	53	200	400	350	450	8-19	5	525	540	800
225M	2	60	140	18	53	225	500	450	550	8-19	5	615	590	890
225M	4/6/8	65	140	18	58	225	500	450	550	8-19	5	615	590	890
250S/M	2	65	140	18	58	250	600	550	660	8-24	6	665	660	960
250S/M	4/6/8	75	140	20	67.5	250	600	550	660	8-24	6	665	660	960
280S/M	2	65	140	18	58	280	600	550	660	8-24	6	740	750	1056
280S/M	4/6/8	80	170	22	71	280	600	550	660	8-24	6	740	750	1086
315(A)	2	70	140	20	62.5	315	740	680	800	8-24	6	900	875	1420
315(A)	4/6/8	90	170	25	81	315	740	680	800	8-24	6	900	875	1455
315(B)	2	80	140	22	71	315	740	680	800	8-24	6	900	875	1595
315(B)	4/6/8	90	170	25	81	315	740	680	800	8-24	6	900	875	1630
355M/L	2	80	170	22	71	355	940	880	1000	8-20	6	723	1228	1628
355M/L	4/6/8	100	210	28	90	355	940	880	1000	8-20	6	723	1228	1670

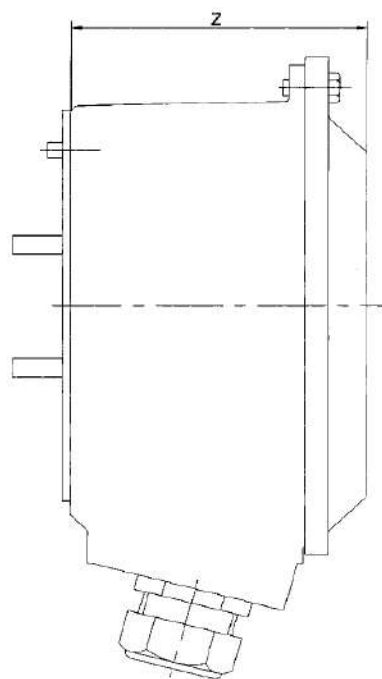
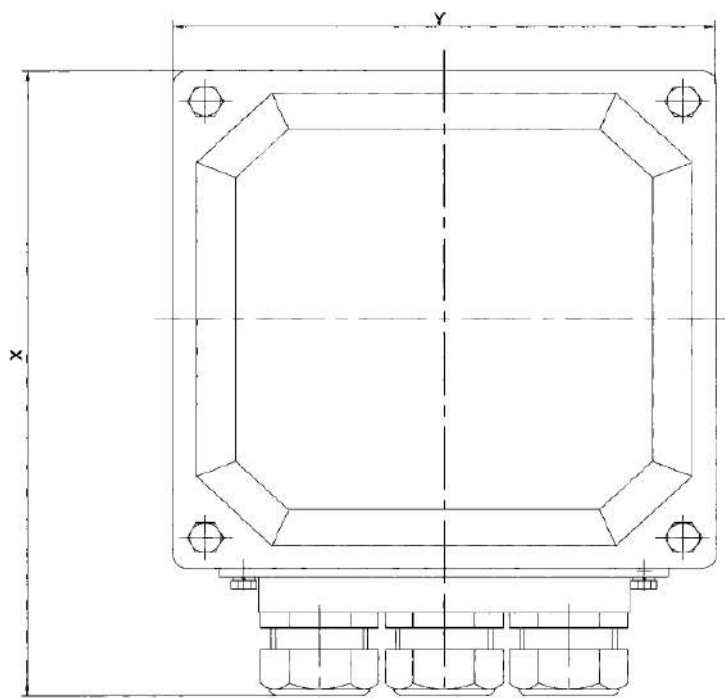

Frame size	X	Y	Z	Dia. of the gland
160M/L	200	250	115	2-M50x1.5
180M/L	200	250	115	2-M50x1.5
200M/L	226	280	123	2-M63x1.5
225M	226	280	123	2-M63x1.5
250S/M	303	335	166	2-M63x1.5
280S/M	370	470	170	2-M63x1.5
315S/M/L	370	470	170	3-M63x1.5
355S/M/L	430	560	240	3-M63x1.5

CUSCINETTI BEARINGS

E3 B35 B5				
Frame size	Driving End		Non-driving End	
	2 (pole)	4/6/8 (pole)	2 (pole)	4/6/8 (pole)
160	6310C3	6309C3	6310C3	6309C3
180	6312C3	6312C3	6312C3	6312C3
200	6313C3	6313C3	6313C3	6313C3
225	6314C3	6314C3	6314C3	6314C3
250	6314C3	6317C3	6314C3	6317C3
280	6314C3	6318C3	6314C3	6318C3
315	6317C3	6319C3(NU319)	6317C3	6319C3
355	6319C3	6322C3(NU322)	6319C3	6320C3

V1				
Frame size	Driving End		Non-driving End	
	2 (pole)	4/6/8 (pole)	2 (pole)	4/6/8 (pole)
315	6317C3	6319C3(NU319)	7317	7319
355	6319C3	6322C3(NU322)	7319	7320

VIBRAZIONI VIBRATION

Frame size	≤132		>132-225		>225-400	
	600~1800	>1800~3600	600~1800	>1800~3600	500~1800	>1800~3600
Synchronous Speed r/min						
Vibration Class	Effective Value of speed mm/s					
N	1.8		2.8		3.5	
R	0.71	1.12	1.12	1.80	1.80	2.80
S	0.45	0.71	0.71	1.12	1.12	1.80

All data listed in the tables are indicative and not binding. The guaranteed values are upon request. Felm srl reserves the right to change the project, the technical characteristics and dimensions at any time without previous notice.

CONTACTS

Head Quarter

FELM srl

Via Morandi (Industrial Area)

20010 Inveruno (Mi) Italy

Tel. +39 02 97 289 454

Tel. +39 02 97 288 320

Fax +39 02 97 289 923

E-mail home@felm.it



FELM Office Germany

Heinrich-Busold-Strasse 47

D-61169 Fridberg (Hessen), Germany

Tel. (Off.) +49 6331 721606

Mobile +49 172 6729011

E-mail Jayant@jk-conrep.de

FELM Office China

Room 1002, Building 3#, No.139 Rd. SongShan

Jianye, Nanjing, Jiangsu, China

Te. +86 150 778 29 999

Fax +86 25 87 797 622

E-mail lidongming1974@vip.sina.com



FELM Office Middle East

Al Saalam Street, Al Darwish Building (NBAD building)

office no. 1403 Abu Dhabi (United Arab Emirates)

P.O. Box 45223

Office Ph. + 971-2-6710330

Office Fax + 971-2-6710255

mobile +971 50 4442093

WORLD WIDE SERVICE

Mobile +39 355 69 53 804

E-mail service@felm.it



WATER JACKET

Low Voltage



GENERAL CHARACTERISTICS

The designing, manufacturing and testing of squirrel cage induction motors made by Felm® are in according to IEC standard, Felm® supply high quality steel frame motors with high performance and flexibility to meet the customer request. The motors are widely used in various industries of mining, pumps, compressors, wind machineries, fans ect.

Water Jacket Motors Technical details:

Number of Poles: 4 up to 12	
Frequency: 50 Hz.	(Optional: 60 Hz.)
Voltage: 400/690	(Optional: other rated voltages)
Frames: 355 up to 630	kW 355 ÷ 1700
Steel welded frame	
Cooling system: IC71W	(Inverter use rated 1:10)
Die casting Rotor	
Shaft sealing: O-Ring	
VPI Insulation System	
Insulation class F (class B temperature rise)	(Options: Class H)
Stator windings:	Random windings 355 ÷ 450
	Formed winding 500 ÷ 630
	(Options: IP56 - IP65)
	(Options: B3/B5-V1)
	According to ISO 12944-5
Degree of protection: IP55	
Mounting: B3	
Painting procedure:	
Final color: RAL 5010	
Internal epoxy coating (tropicalized)	
Sintered drain plug	
Terminal box :	Top, Left or Right
Shaft Material: C45	
Double grounding (1 inside terminal box + 2 on the frame)	
Grease Caltex SRI-2 or SKF LGHP2	(Different types recommended by Felm)
Options:	
Regreasing system	
Space Heaters	
PT100 windings and bearings	
Transmitters	
CT's Transformer	
Surge Arrestor & Capacitor & Suppressor	
Vibration probes	
Junction box	
Predisposition and supply of all type of Encoder	
Special shaft materials	
DC or AC Brake	

Water Jacket - Technical data 4 pole

Motor Type FWJ	Rated Power		Rated Speed	Efficiency	Power Factor	Current			Torque			Moment of inertia (J)	Approx WT
	kW	(HP)				RPM	%	%	Full Load 400 V	Full Load 690 V	Locked Rotor		
			A	A	%FLC				kg-m	%FLT	%FLT	kg-m ²	Kg
355-4	355	475	1485	95,4	87,0	617	358	700	233	140	200	8.6	2010
355-4	400	535	1485	95,5	87,0	695	403	700	262	140	200	9.2	2170
355-4	450	605	1485	95,6	87,0	781	453	700	295	140	200	10	2230
355-4	500	670	1485	95,6	87,0	868	503	750	328	140	200	10.6	2410
355-4	560	750	1485	95,7	87,0	971	563	750	367	140	220	11	2530
400-4	560	750	1488	95,7	87,0	971	563	700	367	120	220	16	2920
400-4	630	845	1488	95,7	87,0	1092	633	700	413	120	220	18.3	3125
400-4	710	950	1488	95,8	87,0	1230	713	750	465	120	220	19.5	3380
400-4	800	1070	1488	95,8	87,0	--	803	750	524	120	220	21	3560
450-4	800	1070	1488	95,8	87,0	--	803	750	524	110	220	29	3970
450-4	900	1205	1490	95,9	87,0	--	903	750	589	110	220	25	4190
450-4	1000	1340	1490	96,0	87,0	--	1002	750	654	110	220	29	5575
450-4	1120	1500	1490	96,0	87,0	--	1122	750	733	110	220	33	4725
500-4	1120	1500	1490	95,9	87,0	--	1123	750	733	90	220	40	5400
500-4	1250	1680	1492	96,0	87,0	--	1252	750	816	90	200	45	5818
500-4	1400	1880	1492	96,1	87,0	--	1401	750	914	90	200	49	6450
560-4	1400	1880	1492	96,0	88,0	--	1387	750	914	80	200	59	7030
560-4	1500	2010	1490	96,1	88,0	--	1484	750	981	80	200	63	7410
560-4	1600	2140	1490	96,2	88,0	--	1581	750	1046	80	200	67	7845
560-4	1700	2280	1490	96,2	88,0	--	1680	750	1112	80	200	72	8275

Water Jacket - Technical data 6 pole

Motor Type FWJ	Rated Power		Rated Speed	Efficiency	Power Factor	Current			Torque			Moment of inertia (J) kg-m ²	Approx WT Kg
						Full Load 400 V	Full Load 690 V	Locked Rotor	Full Load	Locked Rotor	Break down		
	kW	(HP)	RPM	%	%	A	A	%FLC	kg-m	%FLT	%FLT		
355-6	400	535	990	95,2	84,0	722	419	700	394	130	200	13	2500
400-6	450	605	990	95,2	84,0	812	471	680	443	120	200	19	3075
400-6	500	670	990	95,3	84,0	902	523	680	492	120	200	21	3280
400-6	560	750	990	95,3	84,0	1010	585	680	551	120	200	22	3485
400-6	630	845	990	95,4	84,0	1135	658	700	620	120	200	24	3690
450-6	630	845	990	95,3	85,0	1123	651	700	620	110	200	31	4090
450-6	710	950	990	95,4	85,0	1264	733	700	699	110		35	4380
450-6	800	1070	990	95,4	85,0	--	826	700	787	110		39	4690
450-6	900	1205	990	95,5	85,0	--	928	700	886	110		43	4975
500-6	900	1205	990	95,4	85,0	--	929	700	886	100		45	5230
500-6	1000	1340	990	95,6	85,0		1030	700	984	100		50	5520
500-6	1120	1500	990	95,6	85,0		1153	700	1102	100		53	5980
500-6	1250	1680	990	95,7	85,0		1286	700	1230	100		58	6350
560-6	1250	1680	992	95,7	86,0	--	1271	700	1228	90		65	6900
560-6	1400	1880	992	95,7	86,0		1423	700	1375	90		70	7300
560-6	1500	2010	992	95,8	86,0		1523	700	1474	90		76	7800
560-6	1600	2140	992	95,9	86,0		1623	700	1572	90		82	8305

Water Jacket - Technical data 8 pole

Motor Type FWJ	Rated Power		Rated Speed	Efficiency	Power Factor	Current			Torque			Moment of inertia (J)	Approx WT
	kW	(HP)				RPM	%	%	Full Load 400 V	Full Load 690 V	Locked Rotor		
			A	A	%FLC				kg-m	%FLT	%FLT	kg-m ²	Kg
355-8	355	475	740	94,7	80,0	676			467	120	14	2670	
400-8	355	475	742	94,8	81,0	667			466	120	20	3410	
400-8	400	535	742	95,8	81,0	744			525	120	22	3540	
400-8	450	605	742	94,9	81,0	845			591	120	23	3745	
400-8	500	670	742	95,0	81,0	938			657	120	25	4000	
450-8	500	670	742	95,1	81,0	937			657	120	32	4630	
450-8	560	750	742	95,2	81,0	1048			735	120	38	4945	
450-8	630	845	742	95,3	81,0	1178			827	120	45	5260	
500-8	630	845	743	95,3	81,0	1178			826	110	50	5680	
500-8	710	950	743	95,4	81,0	--			931	110	56	6050	
500-8	800	1070	743	95,5	81,0	--			1049	110	62	6385	
500-8	900	1205	743	95,6	81,0	--			1180	110	65	6720	
560-8	900	1205	744	95,6	82,0	--			1179	100	75	7120	
560-8	1000	1340	744	95,7	82,0	--			1310	100	81	7630	
560-8	1120	1500	744	95,8	82,0	--			1467	100	88	8120	
560-8	1250	1680	744	95,9	82,0	--			1637	100	95	8780	

MOUNTING DIMENSIONS INSTALLATION B3

A-A

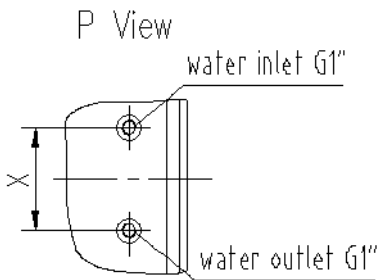
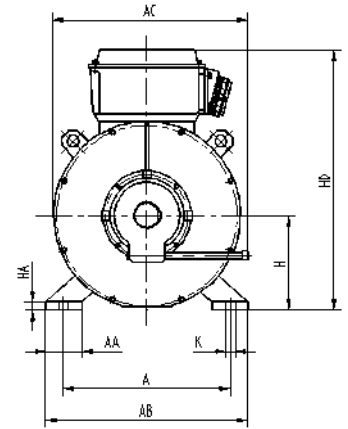
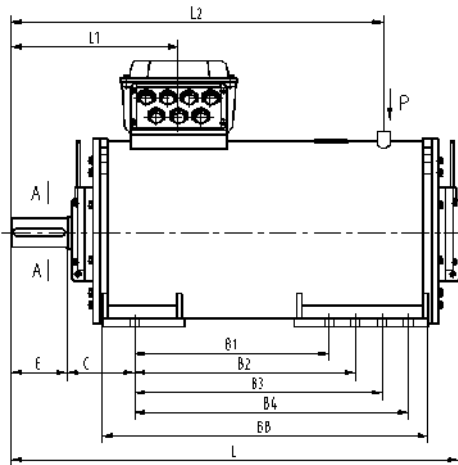
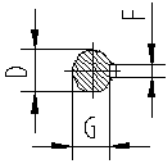

● OUTLINE DIMENSIONS FOR INSTALLATION

Frames	Poles	MOUNTING											
		A	B1	B2	B3	B4	C	D	E	F	G	H	K
355	4~8	630±1.4	630	710	800	-	254±4	100 ^{+0.035} _{+0.013}	210±0.5	28	90 ⁰ _{-0.2}	355 ⁰ ₋₁	35 ^{+0.52} ₀
400	4~8	710±1.6	710	800	900	-	280±4	110 ^{+0.035} _{+0.013}	210±0.57	28	100 ⁰ _{-0.2}	400 ⁰ ₋₁	35*47
450	4~8	800±1.75	900	1000	1120	1250	280±4	120 ^{+0.035} _{+0.013}	210±0.57	32	109 ⁰ _{-0.2}	450 ⁰ ₋₁	35*75
500	4~8	900±2.1	1250±2.1				315±4	140 ^{+0.04} _{+0.015}	250±0.57	36	128 ⁰ _{-0.3}	500 ⁰ ₋₁	42*60
560	4~8	1000±2.1	1400±2.1				355±4	160 ^{+0.04} _{+0.015}	300±0.65	40	147 ⁰ _{-0.3}	560 ⁰ ₋₁	42*60

● OUTLINE DIMENSIONS FOR INSTALLATION

Frames	Poles	OUTLINE									
		AC	AA	AB	BB	HA	HD	L1	L2	X	L
355	4~8	750	135	760	1150	40	1020	630	1400	240	1650
400	4~8	830	160	870	1320	40	1120	670	1600	240	1860
450	4~8	920	210	980	1480	42	1280	710	1800	240	2070
500	4~8	1010	225	1080	1620	45	1350	760	2000	240	2260
560	4~8	1100	250	1170	1780	45	1450	810	2150	240	2470

MOUNTING DIMENSIONS INSTALLATION V1

A-A

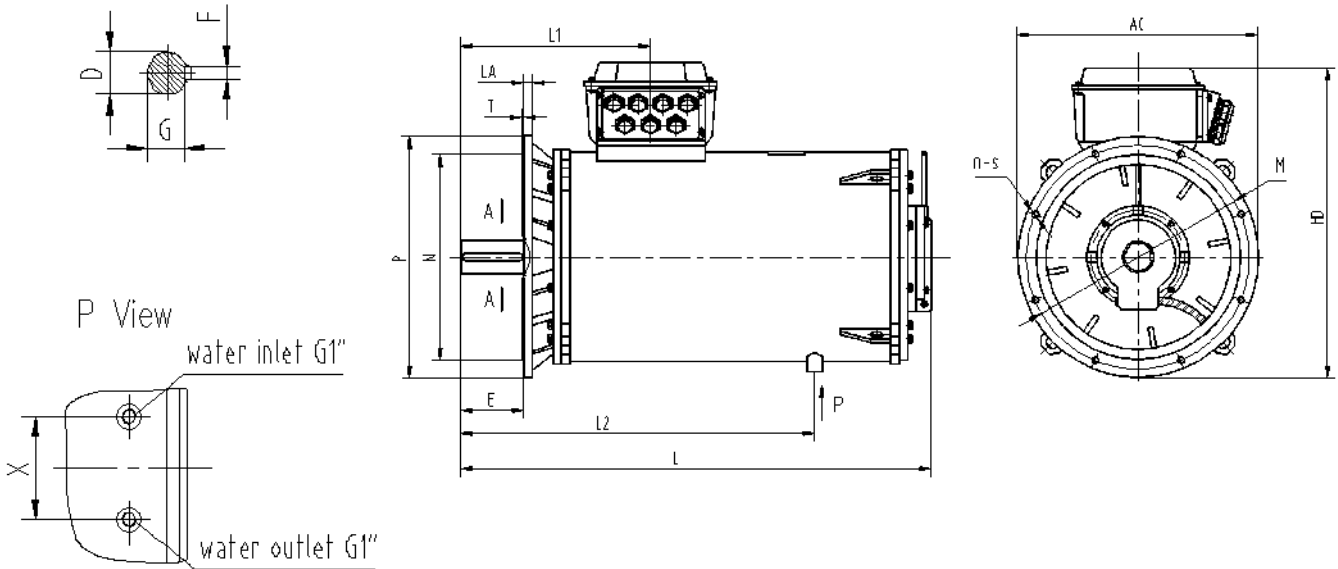

● MOUNTING DIMENSIONS FOR INSTALLATION

Frames	Poles	MOUNTING														
		D	E	F	G	M	N	P	n-S	T	LA	HD	X	L1	L2	L
355	4~8	100 ^{+0.035} _{+0.013}	210	28 ⁰ ₋	90 ⁰ _{-0.2}	740	680	800	8-24	6	25	1065	240	630	1300	1550
400	4~8	110 ^{+0.035} _{+0.013}	210	28 ⁰ ₋	100 ⁰ _{-0.2}	940	880	1000	8-28	6	25	1220	240	670	1500	1750
450	4~8	120 ^{+0.035} _{+0.013}	210	32 ⁰ ₋	109 ⁰ _{-0.2}	1080	1000	1150	8-28	6	30	1410	240	710	1700	1950

MOUNTING DIMENSIONS INSTALLATION B3/B5

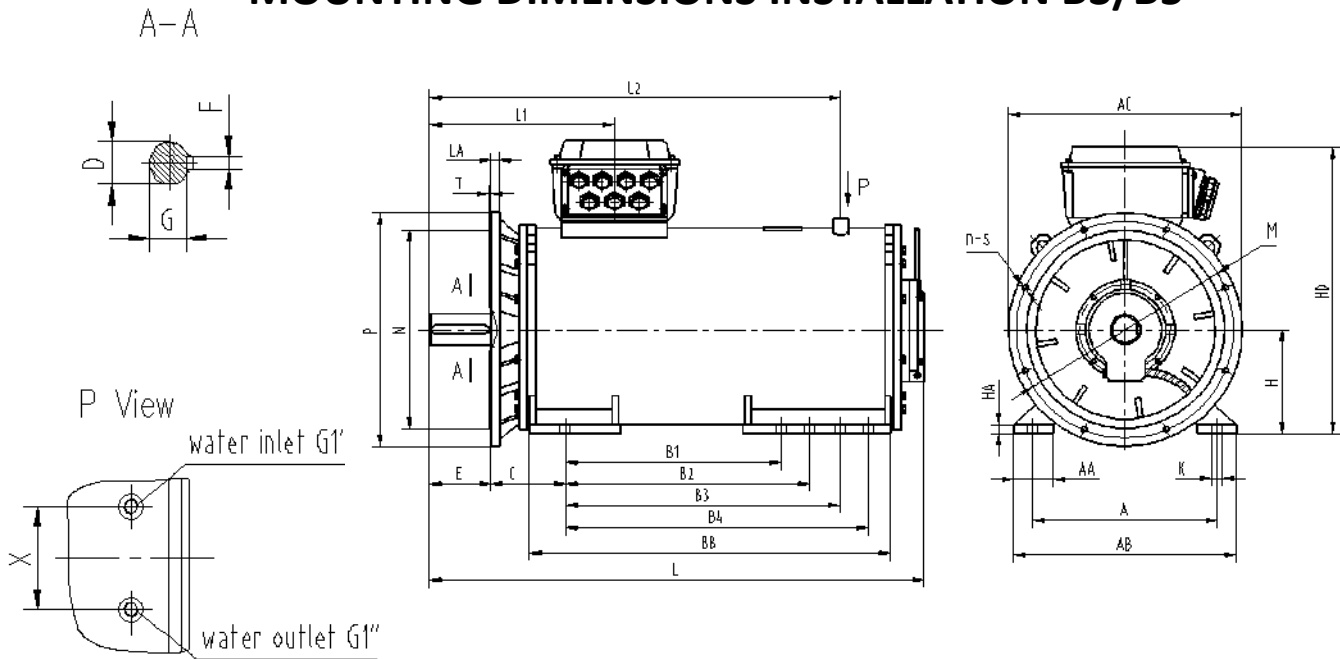

● MOUNTING DIMENSIONS FOR INSTALLATION

Frames	Poles	MOUNTING											
		A	B1	B2	B3	B4	C	D	E	F	G	H	K
355	4~8	630±1.4	630	710	800	-	254±4	100 ^{+0.035} _{+0.013}	210±0.5	28	90 ⁰ ₋	355 ⁰ ₋₁	35 ^{+0.5} ₀
400	4~8	686/710	710	800	900	-	280±4	110 ^{+0.035} _{+0.013}	210±0.57	28	100 ⁰ ₋	400 ⁰ ₋₁	35*47
450	4~8	800±1.75	900	1000	1120	1250	280±4	120 ^{+0.035} _{+0.013}	210±0.57	32	109 ⁰ ₋	450 ⁰ ₋₁	35*75
500	4~8	900±2.1	1250±2.1				315±4	140 ^{+0.04} _{+0.015}	250±0.57	36	128 ⁰ ₋	500 ⁰ ₋₁	42*60
560	4~8	1000±2.1	1400±2.1				355±4	160 ^{+0.04} _{+0.015}	300±0.65	40	147 ⁰ ₋	560 ⁰ ₋₁	42*60

● OUTLINE DIMENSIONS FOR INSTALLATION

Frames	Poles	OUTLINE						OUTLINE									
		M	N	P	n-S	T	LA	AA	AB	AC	BB	HA	HD	X	L1	L2	L
355	4~8	740	680	800	8-24	6	25	135	760	800	1150	40	1020	240	630	1400	1650
400	4~8	940	880	1000	8-28	6	25	160	870	1000	1320	40	1120	240	670	1600	1860
450	4~8	1080	1000	1150	8-28	6	30	210	980	1150	1480	42	1280	240	710	1800	2070
500	4~8	1180	1120	1250	8-28	7	32	225	1080	1250	1620	45	1350	240	760	2000	2260
560	4~8	1180	1120	1250	8-28	7	32	250	1170	1250	1780	45	1450	240	810	2150	2470

CONTACTS

Head Quarter

FELM srl

Via Morandi (Industrial Area)

20010 Inveruno (Mi) Italy

Tel. +39 02 97 289 454

Tel. +39 02 97 288 320

Fax +39 02 97 289 923

E-mail home@felm.it

FELM Office Germany

Heinrich-Busold-Strasse 47

D-61169 Friedberg (Hessen), Germany

Tel (Off): +49-6031-721606

Mobile: +49-172-6729011

Fax: +49-6031-721610

Email: Jayant@jk-conrep.de

FELM Office China

Add: Room 1002, Building 3#,

No 139 Rd. SongShan,

Jianye, Nanjing, Jiangsu, China

Fax: +86-25-87797622

Tel: +86-15077829999

Email: lidongming1974@vip.sina.com

FELM Office Middle East

Al Saalam Street, Al Darwish Building (NBAD building)

office no. 1403 Abu Dhabi (United Arab Emirates) P.O. Box 45223

Office Ph. + 971-2-6710330

Office Fax + 971-2-6710255

mobile +971 50 4442093

Email: ayman.abdallah@felm.it

FELM Office UK

The Foundry, Wadebridge

Cornwall, PL277PG

United Kingdom

Tel (Off): +441208 816543

Mobile: +447791717488

Email: Toby@felm.co.uk

WORLD WIDE SERVICE

Mobile +39 355 69 53 804

E-mail service@felm.it





Electric Motors - www.felm.it

SLIP RING MOTORS



FR2 SERIES

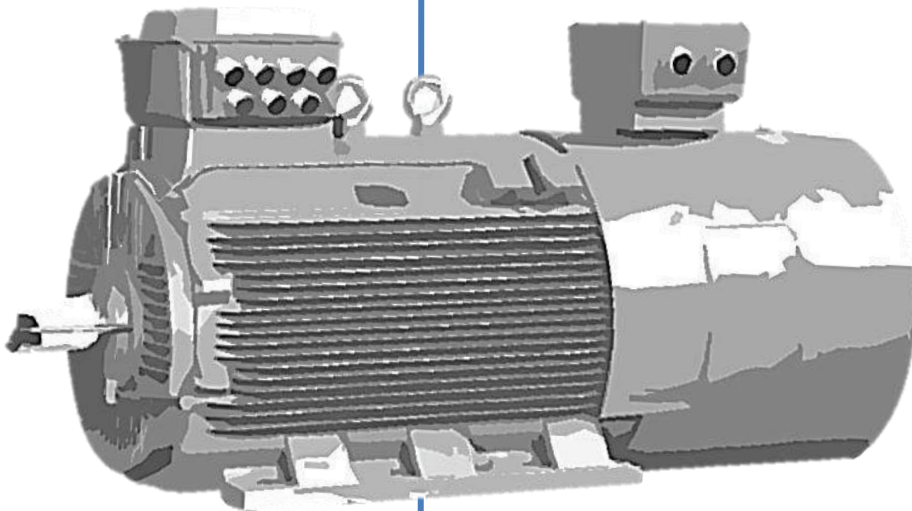



GENERAL CHARACTERISTICS

The design, manufacturing and testing of squirrel cage induction motors made by Felm® are in accordance to IEC standard, Felm supply high quality steel frame motors with high performance and flexibility to meet customer request. The motors are widely used in various industries like: mining, pumps, compressors, wind machineries, fans ect.

With cast iron or welded frame with flange

Power range : 55kW-450kW

Frame range: H280-400

Protection: IP55 *uct advantages*

FR series are slip ring motors that can support big start torque under low start current. They're used:

Big start torque - Low supply line - Long start time and frequent start

Number of Poles: 4-6-8

Cooling system: IC411

(Options IC416)

Die casting Rotor

Shaft sealing:

O-Ring

Deep & Bake insulation

(option double impregnation VI)

Insulation class F (class B temperature rise)

Degree of protection IP55

(Options IP56 - IP65 – IP66)

Mounting: B3

Final colour: RAL 5010

(Options other types of colours)

Painting plan: C2

(Options C3-C4-C5-Marine-Chemical)

Internal epoxy coating

(Options tropicalization - humidity >95%)

Amb. temp.: -20°C/+40°C

(Options amb. up to -40°C)

Sintered drain plug

Terminal box : Top

(Options right or left)

Shaft Material: C45

(Options other types of materials)

Double grounding (1 inside terminal box + 1 on the frame)

Grease Caltex SRI-2 or SKF LGHP2

(Different types recommended by Felm)

Re-greasing devices

Options:

Space Heaters

PT100 windings and bearings

Transmitters

Vibration probes

Junction box

Special shaft materials

Motor Type	● FR2 SERIOUS H280-400 400V IP55					Rotor			Weight
	Rated Power	Current	Rated Speed	Efficiency	Power Factor	Voltage	Current		
	kW	A	r/min	η%	cosφ	V	A	Maximum Torque	Kg
								Rated Torque	
FR2-280S-4	55	98	1480	91	0,89	291	118	3,0	670
FR2-280M-4	75	134	1480	92	0,88	397	116	3,2	740
FR2-280S-6	37	68	985	92	0,86	259	88	3,2	605
FR2-280M-6	45	83	985	92	0,85	300	92	3,0	640
FR2-280S-8	30	65	735	91	0,73	215	85	3,0	600
FR2-280M-8	37	80	735	91	0,73	261	87	3,2	640
FR2-315S-4	90	156	1480	94,5	0,88	215	260	2,6	981
FR2-315M-4	110	193	1485	93,5	0,88	412	162	3,2	1090
FR2-315L-4	132	227	1485	94,5	0,89	496	160	3,2	1200
FR2-315LX-4	160	281	1485	94,5	0,87	620	155	3,2	1250
FR2-315S-6	75	136	990	93,5	0,85	298	153	2,6	1025
FR2-315M-6	90	163	990	93,5	0,85	225	245	2,6	1100
FR2-315L-6	110	199	990	94	0,85	448	148	2,6	1200
FR2-315S-8	55	105	740	93	0,81	265	125	2,6	965
FR2-315M-8	75	143	740	93,2	0,81	315	145	2,6	1041
FR2-315L-8	90	172	740	93,5	0,81	385	140	2,6	1131
FR2-355M-4	200	345	1485	95	0,88	492	248	3,0	1910
FR2-355L-4	250	431	1485	95,2	0,88	573	265	3,0	1995
FR2-355LX-4	280	481	1485	95,5	0,88	625	272	3,0	2040
FR2-355M-6	132	238	990	94	0,85	227	353	2,0	1750
FR2-355MX-6	160	288	990	94,2	0,85	365	265	2,6	1830
FR2-355L-6	200	358	990	94,8	0,85	420	290	2,6	1930
FR2-355M-8	110	206	740	94	0,82	385	175	2,6	1860
FR2-355L-8	132	247	740	94,1	0,82	495	160	2,6	1950
FR2-355LX-8	160	299	740	94,2	0,82	575	165	2,6	2030

Motor Type	● FR2 SERIOUS H280-400 400V IP55					Rotor			Weight
	Rated Power	Current	Rated Speed	Efficiency	Power Factor	Voltage	Current		
	kW	A	r/min	η%	cosφ	V	A	Maximum Torque	Kg
								Rated Torque	
FR2-400-4	355	623	1480	94,6	0,87	510	425	2,5	3400
FR2-400-4	400	700	1480	94,8	0,87	572	425	2,6	3470
FR2-400-4	450	786	985	95	0,87	652	416	2,6	3580
FR2-400-4	500	872	985	95,1	0,87	655	464	2,7	3680
FR2-400-6	280	509	735	94,5	0,73	558	308	2,4	3620
FR2-400-6	315	572	1480	94,6	0,91	627	306	2,4	3725
FR2-400-6	355	644	1485	94,7	0,9	719	301	2,4	3930
FR2-400-6	400	724	1485	94,9	0,91	774	315	2,4	4180
FR2-400-6	450	814	1485	95	0,9	912	298	2,5	4420

FR2 Frame 280-400 - IP55 - B3

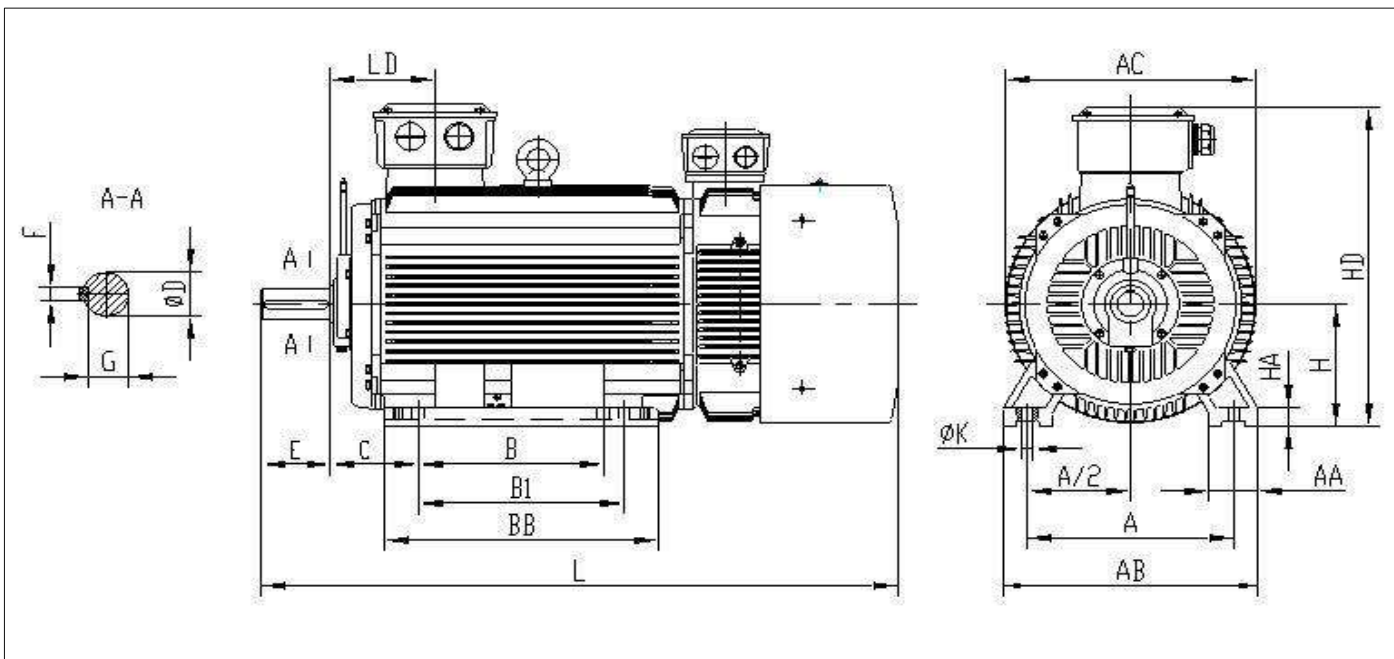

Frame Size	Pole	Mounting Dimensions And Tolerance													
		A	B	B1	C	D	E	F	G	H	K				
280S	4~8	457±1.5	368±1.4	—	190±3	75	+0.030 +0.011	140±0.5	20	0 -0.052	67,5 -0.2	280	0 -1	24	+0.52 0
280M	4~8	457±1.5	419±1.5	—	190±3	75	+0.030 +0.011	140±0.5	20	0 -0.052	67,5 -0.2	280	0 -1	24	+0.52 0
315S	4~8	508±1.5	406±1.5	—	216±4	80	+0.030 +0.011	170±0.5	22	0 -0.052	71 -0.2	315	0 -1	28	+0.52 0
315M,L	4~8	508±1.5	457±1.5	508±1.5	216±4	80	+0.030 +0.011	170±0.5	22	0 -0.052	71 -0.2	315	0 -1	28	+0.52 0
355M,L	4~8	610±1.6	560±1.5	630±1.6	254±4	100	+0.035 +0.013	210±0.5	28	0 -0.052	90 -0.2	355	0 -1	28	+0.52 0
400	4~8	686	630	710	280±4	110	0,035 -0,013	210±0.5	28	0 -0,052	100 -0,2	400	0 -1	35	0,052 0

Frame Size	Pole	Outline Dimensions								
		AA	AB	AC	BB	HA	HD	LD	L	—
280S	4~8	85	545	550	490	35	685	215	1255	—
280M	4~8	85	545	550	540	35	685	215	1305	—
315S	4~8	120	630	625	680	48	845	257	1465	—
315M,L	4~8	120	630	625	680	48	845	257	1575	—
355M,L	4~8	116	730	710	750	52	965	284	1860	—
400	4~8	120	810	870	1090	45	1123	362	2350	—

All data (technical, dimensions, etc..) listed in the tables are indicative and not binding. The guaranteed values are upon request. Felm srl reserves the right to change the project, the technical characteristics and dimensions at any time without previous notice.



CONTACTS

Head Quarter

FELM srl

Via Morandi (Industrial Area)

20010 Inveruno (Mi) Italy

Tel. +39 02 97 289 454

Tel. +39 02 97 288 320

Fax +39 02 97 289 923

E-mail home@felm.it

FELM Office Middle East

Jebel Ali Free Zone, Warehouse no. FZS1-BM07,

PO Box 263632, Dubai, United Arab Emirates

Office Ph. +971 (04) 887 9767

mobile +971 50 550 1322

Email: ayman.abdallah@felm.it

FELM Office Germany

Heinrich-Busold-Strasse 47

D-61169 Friedberg (Hessen), Germany

Tel (Off): +49-6031-721606

Mobile: +49-172-6729011

Fax: +49-6031-721610

Email: Jayant@jk-conrep.de

FELM Office China

Add: Room 1002, Building 3#,

No 139 Rd.SongShan,

Jianye, Nanjing, Jiangsu, China

Fax:+86-25-87797622

Tel:+86-15077829999

Email: lidongming1974@vip.sina.com

FELM Office UK

The Foundry, Wadebridge

Cornwall, PL27 7JP

United Kingdom

Tel (Off): +441208 816543

Email: sales@felm.co.uk

WORLD WIDE SERVICE

Mobile +39 355 69 53 804

E-mail service@felm.it





LARGE MOTORS kV 6-6.6-10-11

HIGH VOLTAGE – HIGH EFFICIENCY & POWER



GENERAL CHARACTERISTICS

The designing, manufacturing and testing of squirrel cage induction motors made by Felm® are in according to IEC standard, Felm supply high quality steel frame motors with high performance and flexibility to meet the customer request. The motors are widely used in various industries of mining, pumps, compressors, wind machineries, fans ect.

Compact Series Motors Technical details:

Efficiency level: Premium IE3 Motors < 220 kW - > 2500 kW High efficiency level	
Number of Poles: 2 up to 12	
Frequency: 50 Hz.	(Optional: 60 Hz.)
Voltage: 6-6.6-11 kV	(Optional: other rated voltages)
Frames: 355 up to 630	
Steel welded frame	
Cooling system: IC611	(Options IC 616: Inverter use rated 1:10)
Copper bar Rotor	
Shaft sealing: O´Ring	
VPI Insulation System	
Insulation class F (class B temperature rise)	(Options: Class H)
Formed winding	
Degree of protection: IP55	(Options: IP56 - IP65)
Mounting: B3	(Options: V1)
Painting procedure:	According to ISO 12944 S
Final color: RAL 5010	
Internal epoxy coating (tropicalized)	
Sintered drain plug	
Terminal box on side:	Left or Right
Shaft Material: C45	
Double grounding (1 inside terminal box + 2 on the frame)	
Grease Caltex SRI-2 or SKF LGHP2	(Different types recommended by Felm)
Regreasing system	

Options:

- Space Heaters
- PT100 windings and bearings
- Transmitters
- CT's Transformer
- Surge Arrestor & Capacitor & Suppressor
- Vibration probes
- Junction box
- Predisposition and All type of Encoder
- Special shaft materials
- DC or AC Brake



kV 6 - 6.6 Technical data 2 pole – 4 pole

Motor Type	Rated Power		Rated Speed	Efficiency	Power Factor	Current Full Load 6 kV	Current Full Load 6.6 kV	Current Locked Rotor	Torque Full Load	Torque Locked Rotor	Torque Pull Out	Moment of inertia (J)	Noise level	Approx WT
	kW	(HP)												
FAA3551-2	220	295	2975	93,1	85	26,8	24,3	700	72	60	180	3,5		2590
FAA3552-2	250	335	2975	93,2	85	30,4	27,6	700	82	60	180	3,8		2650
FAA3553-2	280	375	2975	93,4	85	33,9	30,9	700	92	60	180	4,0		2710
FAA3554-2	315	420	2975	93,7	85	38,1	34,6	700	103	60	180	4,3		2780
FAA4002-2	355	475	2980	93,9	86	42,3	38,5	700	116	60	180	5,2		3070
FAA4003-2	400	535	2980	94,2	86	47,5	43,2	700	131	60	180	5,5		3170
FAA4004-2	450	605	2980	94,4	86	53,3	48,5	700	147	60	180	5,8		3260
FAA4005-2	500	670	2980	94,7	86	59,1	53,7	700	164	60	180	6,2		3360
FAA4502-2	560	750	2980	94,9	86	66,0	60,0	700	183	60	180	9,0		4140
FAA4503-2	630	845	2980	95,0	87	73,3	66,7	700	206	60	180	11,0		4270
FAA4504-2	710	950	2980	95,1	87	82,6	75,1	700	232	60	180	13,0		4410
FAA4505-2	800	1070	2980	95,3	87	92,8	84,4	700	262	60	180	15,0		4530
FAA5001-2	900	1210	2980	95,5	87	104,2	94,8	700	294	60	180	17,0		5300
FAA5002-2	1000	1340	2980	95,5	87	115,8	105,3	700	327	60	180	19,0		5490
FAA5003-2	1120	1500	2980	95,6	87	129,6	117,8	700	366	60	180	21,0		5680
FAA5004-2	1250	1680	2980	95,8	87	144,3	131,2	700	409	60	180	23,0		5870
FAA5601-2	1400	1880	2980	95,9	88	159,6	145,1	700	458	60	180	39,0		6960
FAA5602-2	1600	2140	2980	96,0	88	182,2	165,7	700	523	60	180	44,0		7240
FAA5603-2	1800	2410	2980	96,0	88	205,0	186,4	700	589	60	180	51,0		7520
FAA6301-2	2000	2680	2982	96,2	88	227,3	206,7	700	654	60	180	70,0		9150
FAA6302-2	2240	3000	2982	96,3	88	254,4	231,2	700	732	60	180	78,0		9500
FAA6303-2	2500	3350	2982	96,4	88	283,6	257,8	700	817	60	180	85,0		9850
FAA3551-4	185	250	1485	93,3	85	22,4	20,4	650	121	70	180	4,7		2170
FAA3552-4	200	270	1480	93,4	85	24,2	22,0	650	132	70	180	4,8		2240
FAA3553-4	220	295	1480	93,5	85	26,6	24,2	650	145	70	180	5,0		2310
FAA3554-4	250	335	1480	93,6	85	30,2	27,5	650	165	70	180	5,7		2380
FAA4002-4	280	375	1485	93,7	86	33,4	30,4	650	184	70	180	12,0		2970
FAA4003-4	315	420	1485	93,8	86	37,6	34,2	650	207	70	180	12,0		3060
FAA4004-4	355	475	1485	94,0	86	42,3	38,4	650	233	70	180	13,0		3150
FAA4005-4	400	535	1485	94,2	86	47,5	43,2	650	262	70	180	14,0		3240
FAA4006-4	450	605	1485	94,4	86	53,3	48,5	650	295	70	180	16,0		3330
FAA4502-4	500	670	1485	94,5	86	59,2	53,8	650	328	70	180	16,0		3950
FAA4503-4	560	750	1485	94,7	86	66,2	60,2	650	367	70	180	17,0		4080
FAA4504-4	630	845	1485	94,9	86	74,3	67,5	650	413	70	180	19,0		4210
FAA4505-4	710	950	1485	95,0	86	83,6	76,0	650	466	70	180	20,0		4350
FAA5001-4	800	1070	1485	95,3	87	92,8	84,4	650	525	70	180	29,0		5330
FAA5002-4	900	1210	1485	95,4	87	104,3	94,9	650	591	70	180	32,0		5520
FAA5003-4	1000	1340	1485	95,5	87	115,8	105,3	650	656	70	180	34,0		5710
FAA5004-4	1120	1500	1485	95,5	87	129,7	117,9	650	735	70	180	37,0		5900
FAA5601-4	1250	1680	1485	95,7	88	142,8	129,8	650	820	60	180	55,0		7020
FAA5602-4	1400	1880	1485	95,8	88	159,8	145,3	650	919	60	180	60,0		7300
FAA5603-4	1600	2140	1485	95,9	88	182,4	165,9	650	1050	60	180	65,0		7580
FAA6301-4	1800	2410	1485	96,0	88	205,0	186,4	650	1181	60	180	126,0		8800
FAA6302-4	2000	2680	1485	96,1	88	227,6	206,9	650	1312	60	180	140,0		9150
FAA6303-4	2240	3000	1485	96,2	88	254,6	231,5	650	1470	60	180	156,0		9580

kV 6 - 6.6 Technical data 6 pole – 8 pole



Motor Type	Rated Power		Rated Speed	Efficiency	Power Factor	Current Full Load 6 kV	Current Full Load 6.6 kV	Current Locked Rotor	Torque Full Load	Torque Locked Rotor	Torque Pull Out	Moment of inertia (J)	Noise level	Approx WT
	kW	(HP)												
FAA4001-6	185	250	990	93,0	82	23,3	21,2	600	182	70	180	13,0		3150
FAA4002-6	200	270	990	93,1	82	25,2	22,9	600	197	70	180	14,0		3240
FAA4003-6	220	295	990	93,3	82	27,7	25,2	600	217	70	180	15,0		3350
FAA4004-6	250	335	990	93,5	82	31,4	28,5	600	246	70	180	16,0		3440
FAA4005-6	280	375	990	93,8	82	35,0	31,8	600	276	70	180	16,0		3550
FAA4006-6	315	420	990	94,0	82	39,3	35,8	600	310	70	180	17,0		3660
FAA4502-6	355	475	985	94,2	83	43,7	39,7	600	351	70	180	24,0		4080
FAA4503-6	400	535	985	94,3	83	49,2	44,7	600	396	70	180	25,0		4210
FAA4504-6	450	605	985	94,5	83	55,2	50,2	600	445	70	180	26,0		4340
FAA4505-6	500	670	985	94,8	83	61,1	55,6	600	495	70	180	28,0		4480
FAA5001-6	560	750	990	94,9	84	67,6	61,5	600	551	70	180	42,0		4980
FAA5002-6	630	845	990	95,0	84	76,0	69,1	600	620	70	180	45,0		5170
FAA5003-6	710	950	990	95,2	84	85,4	77,7	600	699	70	180	47,0		5360
FAA5004-6	800	1070	990	95,4	84	96,1	87,3	600	787	70	180	50,0		5550
FAA5601-6	900	1210	990	95,5	85	106,7	97,0	650	886	70	180	74,0		6350
FAA5602-6	1000	1340	990	95,5	85	118,5	107,8	650	984	70	180	79,0		6630
FAA5603-6	1120	1500	990	95,6	85	132,6	120,6	650	1102	70	180	85,0		6910
FAA6301-6	1250	1680	990	95,8	86	146,0	132,7	650	1230	70	180	140,0		8650
FAA6302-6	1400	1880	990	95,9	86	163,3	148,5	650	1378	70	180	151,0		9010
FAA6303-6	1600	2140	990	96,0	86	186,5	169,5	650	1575	70	180	164,0		9350
FAA6303-6	1800	2410	990	96,1	86	209,6	190,5	650	1772	70	180	164,0		9720
FAA4003-8	185	250	740	93,0	78	24,5	22,3	550	244	80	180	20,0		3230
FAA4004-8	200	270	740	93,2	78	26,5	24,1	550	263	80	180	20,0		3350
FAA4005-8	220	295	740	93,4	78	29,1	26,4	550	290	80	180	21,0		3490
FAA4502-8	250	335	740	93,5	79	32,6	29,6	550	329	80	180	25,0		3900
FAA4503-8	280	375	740	93,7	79	36,4	33,1	550	369	80	180	27,0		4110
FAA4504-8	315	420	740	93,9	79	40,9	37,1	550	415	80	180	29,0		4350
FAA4505-8	355	475	740	94,0	79	46,0	41,8	550	467	80	180	31,0		4610
FAA5001-8	400	535	740	94,2	80	51,1	46,4	550	527	80	180	46,0		4480
FAA5002-8	450	605	740	94,3	80	57,4	52,2	550	593	80	180	50,0		4570
FAA5003-8	500	670	740	94,7	80	63,5	57,7	550	658	80	180	53,0		4740
FAA5004-8	560	750	740	94,9	80	71,0	64,5	550	737	80	180	57,0		4930
FAA5601-8	630	845	740	95,0	82	77,8	70,7	600	830	70	180	88,0		8480
FAA5602-8	710	950	740	95,0	82	87,7	79,7	600	935	70	180	94,0		8620
FAA5603-8	800	1070	740	95,2	82	98,6	89,6	600	1054	70	180	100,0		8960
FAA6301-8	900	1210	740	95,3	84	108,2	98,4	600	1185	70	180	152,0		8810
FAA6302-8	1000	1340	740	95,4	84	120,1	109,2	600	1317	70	180	163,0		9140
FAA6303-8	1120	1500	740	95,5	84	134,3	122,1	600	1475	70	180	175,0		9410
FAA6304-8	1250	1680	740	95,6	84	149,8	136,2	600	1646	70	180	188,0		9910



kV 6 - 6.6 Technical data 10 pole – 12 pole

Motor Type	Rated Power		Rated Speed	Efficiency	Power Factor	Current Full Load 6 kV	Current Full Load 6.6 kV	Current Locked Rotor	Torque Full Load	Torque Locked Rotor	Torque Pull Out	Moment of inertia (J)	Noise level	Approx WT
	kW	(HP)												
FAA4501-10	185	250	585	92,4	75	25,7	23,4	550	308	80	180	25,0		3860
FAA4502-10	200	270	585	92,6	75	27,7	25,2	550	333	80	180	27,0		3980
FAA4503-10	220	295	585	92,7	75	30,4	27,7	550	366	80	180	29,0		4120
FAA4504-10	250	335	585	92,9	75	34,5	31,4	550	416	80	180	31,0		4260
FAA4505-10	280	375	585	93,1	75	38,6	35,1	550	466	80	180	25,0		4440
FAA5001-10	315	420	585	93,4	76	42,7	38,8	550	525	80	180	54,0		4880
FAA5002-10	355	475	585	93,6	76	48,0	43,7	550	591	80	180	58,0		5000
FAA5003-10	400	535	585	93,8	76	54,0	49,1	550	666	80	180	63,0		5140
FAA5004-10	450	605	585	93,9	76	60,7	55,2	550	750	80	180	66,0		5320
FAA5601-10	500	670	590	94,2	78	65,5	59,5	600	826	70	180	103,0		9030
FAA5602-10	560	750	590	94,3	78	73,3	66,6	600	925	70	180	112,0		9300
FAA5603-10	630	845	590	94,4	78	82,3	74,8	600	1041	70	180	120,0		9590
FAA5604-10	710	950	590	94,5	78	92,7	84,3	600	1173	70	180	129,0		9900
FAA6301-10	800	1070	590	94,8	80	101,5	92,3	600	1321	70	180	171,0		8510
FAA6302-10	900	1210	590	94,9	80	114,1	103,7	600	1487	70	180	186,0		8710
FAA6303-10	1000	1340	590	95,0	80	126,6	115,1	600	1652	70	180	202,0		9310
FAA6304-10	1120	1500	590	95,1	80	141,7	128,8	600	1850	70	180	219,0		9710
FAA4504-12	185	250	490	92,5	70	27,5	25,0	550	368	80	180	40,0		3980
FAA4505-12	200	270	490	92,6	70	29,7	27,0	550	398	80	180	42,0		4120
FAA5001-12	220	295	490	92,8	72	31,7	28,8	550	438	80	180	51,0		4880
FAA5002-12	250	335	490	93,1	72	35,9	32,6	550	497	80	180	55,0		5030
FAA5003-12	280	375	490	93,3	72	40,1	36,5	550	557	80	180	60,0		5220
FAA5004-12	315	420	490	93,4	72	45,1	41,0	550	626	80	180	67,0		5410
FAA5601-12	355	475	490	93,6	74	49,3	44,8	600	706	70	180	111,0		8930
FAA5602-12	400	535	490	93,8	74	55,5	50,4	600	796	70	180	121,0		9150
FAA5603-12	450	605	490	93,9	74	62,3	56,7	600	895	70	180	132,0		9420
FAA5604-12	500	670	490	94,2	74	69,0	62,7	600	994	70	180	145,0		9690
FAA6301-12	560	750	490	94,3	76	75,2	68,4	600	1114	70	180	208,0		9210
FAA6302-12	630	845	490	94,4	76	84,5	76,8	600	1253	70	180	222,0		9490
FAA6303-12	710	950	490	94,5	76	95,1	86,5	600	1412	70	180	238,0		9690
FAA6304-12	800	1070	490	94,8	76	106,8	97,1	600	1591	70	180	255,0		9910

kV 10 – 11 Technical data 2 pole – 4 pole



MotorType	Rated Power		Rated Speed	Efficiency	Power Factor	Current Full Load 10 kV	Current Full Load 11 kV	Current Locked Rotor	Torque Full Load	Torque Locked Rotor	Torque Pull Out	Moment of inertia (J)	Noise level	Approx WT
	kW	(HP)	RPM	%	%	A	A	%FLC	kg-m	%FLT	%FLT	kg-m ²		kg
FAA4002-2	220	295	2975	93,1	85	16,1	14,6	750	72	60	180	5,1		2910
FAA4003-2	250	335	2975	93,2	85	18,2	16,6	750	82	60	180	5,5		2995
FAA4501-2	280	375	2975	93,4	87	19,9	18,1	700	92	60	180	10,6		3420
FAA4502-2	315	420	2975	93,7	87	22,3	20,3	700	103	60	180	11,0		3500
FAA4503-2	355	475	2980	93,9	87	25,1	22,8	700	116	60	180	11,3		3570
FAA4504-2	400	535	2980	94,2	87	28,2	25,6	700	131	60	180	11,8		3670
FAA4505-2	450	605	2980	94,4	87	31,6	28,8	700	147	60	180	12,0		3760
FAA4506-2	500	670	2980	94,7	87	35,0	31,9	700	164	60	180	12,6		3850
FAA5001-2	560	750	2980	94,9	88	38,7	35,2	700	183	60	180	20,0		4790
FAA5002-2	630	845	2980	95,0	88	43,5	39,6	700	206	60	180	21,0		4880
FAA5003-2	710	950	2980	95,1	88	49,0	44,5	700	232	60	180	22,0		4990
FAA5004-2	800	1070	2980	95,3	88	55,1	50,1	700	262	60	180	23,0		5120
FAA5005-2	900	1210	2980	95,5	88	61,8	56,2	700	294	60	180	24,0		5280
FAA5601-2	1000	1340	2980	95,5	89	67,9	61,8	700	327	60	180	39,0		8540
FAA5602-2	1120	1500	2980	95,6	89	76,0	69,1	700	366	60	180	44,0		8860
FAA5603-2	1250	1680	2980	95,8	89	84,6	77,0	700	409	60	180	51,0		9060
FAA6301-2	1400	1880	2982	95,9	89	94,7	86,1	700	458	60	180	65,0		8860
FAA6302-2	1600	2140	2982	96,0	89	108,1	98,3	700	523	60	180	70,0		9060
FAA6303-2	1800	2410	2982	96,0	88	123,0	111,8	700	588	60	180	78,0		9560
FAA6304-2	2000	2680	2982	96,2	89	134,9	122,6	700	654	60	180	85,0		10060
FAA4002-4	220	295	1485	93,5	83	16,4	14,9	700	144	70	180	8,8		2950
FAA4003-4	250	335	1485	93,6	83	18,6	16,9	700	164	70	180	9,2		3035
FAA4501-4	280	375	1485	93,7	86	20,1	18,2	700	184	70	180	13,6		3320
FAA4502-4	315	420	1485	93,8	86	22,5	20,5	700	207	70	180	14,5		3435
FAA4503-4	355	475	1485	94,0	86	25,4	23,0	700	233	70	180	15,0		3495
FAA4504-4	400	535	1485	94,2	86	28,5	25,9	700	262	70	180	16,0		3615
FAA4505-4	450	605	1485	94,4	86	32,0	29,1	700	295	70	180	17,0		3660
FAA4506-4	500	670	1485	94,5	86	35,5	32,3	700	328	70	180	18,1		3740
FAA5001-4	560	750	1485	94,7	87	39,2	35,7	700	367	70	180	28,0		4840
FAA5002-4	630	845	1485	94,9	87	44,1	40,1	700	413	70	180	28,6		5180
FAA5003-4	710	950	1485	95,0	87	49,6	45,1	700	466	70	180	30,0		5430
FAA5004-4	800	1070	1485	95,3	87	55,7	50,6	700	525	70	180	31,2		5690
FAA5005-4	900	1210	1485	95,4	87	62,6	56,9	700	591	70	180	32,5		5940
FAA5601-4	1000	1340	1490	95,5	89	67,9	61,8	650	654	70	180	40,0		8310
FAA5602-4	1120	1500	1490	95,5	89	76,1	69,2	650	733	70	180	46,0		8610
FAA5603-4	1250	1680	1490	95,7	89	84,7	77,0	650	818	70	180	54,0		9010
FAA5604-4	1400	1880	1490	95,8	89	94,8	86,2	650	916	70	180	59,0		9510
FAA6301-4	1400	1880	1490	95,8	88	95,9	87,2	650	916	60	180	87,0		8110
FAA6302-4	1600	2140	1492	95,9	88	109,5	99,5	650	1045	60	180	91,0		8770
FAA6303-4	1800	2410	1492	96,0	88	123,0	111,8	650	1176	60	180	95,0		8990
FAA6304-4	2000	2680	1492	96,1	88	136,5	124,1	650	1306	60	180	99,0		9810



kV 10 – 11 Technical data 6 pole – 8 pole

Motor Type	Rated Power		Rated Speed	Efficiency	Power Factor	Current Full Load 10 kV	Current Full Load 11 kV	Current Locked Rotor	Torque Full Load	Torque Locked Rotor	Torque Pull Out	Moment of inertia (J)	Noise level	Approx WT
	kW	(HP)												
FAA4503-6	250	335	980	93,5	82	18,8	17,1	600	249	70	180	22,0		4860
FAA4504-6	280	375	980	93,8	82	21,0	19,1	600	278	70	180	22,7		4990
FAA4505-6	315	420	980	94,0	82	23,6	21,5	600	313	70	180	24,3		5140
FAA4506-6	355	475	980	94,2	82	26,5	24,1	600	353	70	180	25,1		5300
FAA5001-6	400	535	995	94,3	84	29,2	26,5	650	392	70	180	40,0		4870
FAA5002-6	450	605	995	94,5	84	32,7	29,8	650	441	70	180	43,0		5010
FAA5003-6	500	670	995	94,8	84	36,3	33,0	650	490	70	180	46,0		5160
FAA5004-6	560	750	995	94,9	84	40,6	36,9	650	548	70	180	49,0		5350
FAA5005-6	630	845	995	95,0	84	45,6	41,4	650	617	70	180	51,0		5540
FAA5601-6	710	950	995	95,2	85	50,7	46,1	600	695	70	180	70,0		7860
FAA5602-6	800	1070	995	95,4	85	57,0	51,8	600	784	70	180	73,0		8260
FAA5603-6	900	1210	995	95,5	85	64,0	58,2	600	881	70	180	75,0		8780
FAA5604-6	1000	1340	995	95,5	85	71,1	64,7	600	979	70	180	78,0		9330
FAA6301-6	1120	1500	995	95,6	86	78,7	71,5	600	1097	60	180	127,0		9270
FAA6302-6	1250	1680	995	95,8	86	87,6	79,6	600	1224	60	180	139,0		9860
FAA6303-6	1400	1880	995	95,9	86	98,0	89,1	600	1371	60	180	149,0		10270
FAA6304-6	1600	2140	995	96,0	86	111,9	101,7	600	1567	60	180	157,0		10760
FAA4501-8	200	270	745	93,2	75	16,5	15,0	550	262	70	180	31,0		4810
FAA4502-8	220	295	745	93,4	75	18,1	16,5	550	288	70	180	32,0		4960
FAA5001-8	250	335	745	93,5	77	20,0	18,2	600	327	70	180	39,0		5045
FAA5002-8	280	375	745	93,7	77	22,4	20,4	600	366	70	180	41,0		5100
FAA5003-8	315	420	745	93,9	78	24,8	22,6	600	412	70	180	43,0		5250
FAA5004-8	355	475	745	94,0	78	28,0	25,4	600	464	70	180	45,0		5420
FAA5005-8	400	535	745	94,2	79	31,0	28,2	600	523	70	180	47,0		5210
FAA5006-8	450	605	745	94,3	79	34,9	31,7	600	589	70	180	50,0		5230
FAA5007-8	500	670	745	94,7	79	38,6	35,1	600	654	70	180	52,0		5320
FAA5601-8	500	670	745	94,7	80	38,1	34,6	600	654	70	180	81,0		7360
FAA5602-8	560	750	745	94,7	80	42,7	38,8	600	733	70	180	83,0		7720
FAA5603-8	630	845	745	95,0	80	47,9	43,5	600	824	70	180	88,0		8190
FAA5604-8	710	950	745	95,0	80	53,9	49,0	600	929	70	180	93,5		8640
FAA630A-8	710	950	742	95,0	83	52,0	47,3	600	932	70	180	135,0		8160
FAA6301-8	800	1070	742	95,2	83	58,5	53,1	600	1051	70	180	142,0		8510
FAA6302-8	900	1210	742	95,3	83	65,7	59,7	600	1182	70	180	150,0		8910
FAA6303-8	1000	1340	742	95,4	83	72,9	66,3	600	1313	70	180	158,0		9110
FAA6304-8	1120	1500	742	95,5	83	81,6	74,2	600	1471	70	180	168,0		9510

kV 10 – 11 Technical data 10 pole – 12 pole



Motor Type	Rated Power		Rated Speed	Efficiency	Power Factor	Current Full Load 10 kV	Current Full Load 11 kV	Current Locked Rotor	Torque Full Load	Torque Locked Rotor	Torque Pull Out	Moment of inertia (J)	Noise level	Approx WT
	kW	(HP)												
FAA5003-10	220	295	595	92,7	74	18,5	16,8	550	360	70	180	48,0		4860
FAA5004-10	250	335	595	92,9	74	21,0	19,1	550	409	70	180	50,0		4910
FAA5005-10	280	375	595	93,1	75	23,2	21,0	550	459	70	180	52,0		4990
FAA5006-10	315	420	595	93,4	75	26,0	23,6	550	516	70	180	54,0		5130
FAA5601-10	355	475	595	93,6	77	28,4	25,9	550	581	70	180	89,0		6950
FAA5602-10	400	535	595	93,8	77	32,0	29,1	550	655	70	180	91,0		7240
FAA5603-10	450	605	595	93,9	77	35,9	32,7	550	737	70	180	95,0		7590
FAA5604-10	500	670	595	94,2	78	39,3	35,7	550	819	70	180	99,0		7980
FAA5605-10	560	750	595	94,3	78	44,0	40,0	550	917	70	180	101,0		8350
FAA6301-10	630	845	595	94,4	80	48,2	43,8	600	1032	70	180	165,0		7905
FAA6302-10	710	950	595	94,5	80	54,2	49,3	600	1163	70	180	174,0		8210
FAA6303-10	800	1070	595	94,8	80	60,9	55,4	600	1310	70	180	183,0		8510
FAA6304-10	900	1210	595	94,9	80	68,4	62,2	600	1474	70	180	199,0		8910
FAA6305-10	1000	1340	595	95,0	80	76,0	69,1	600	1638	70	180	210,0		9310
FAA5601-12	250	335	495	93,1	73	21,2	19,3	550	492	70	180	95,0		6360
FAA5602-12	280	375	495	93,3	73	23,7	21,6	550	551	70	180	99,0		6690
FAA5603-12	315	420	495	93,4	73	26,7	24,2	550	620	70	180	103,0		6940
FAA5604-12	355	475	495	93,6	73	30,0	27,3	550	699	70	180	107,0		7300
FAA5605-12	400	535	495	93,8	73	33,7	30,7	550	787	70	180	110,0		7580
FAA6301-12	450	605	495	93,9	74	37,4	34,0	600	886	70	180	158,0		7240
FAA6302-12	500	670	495	94,2	74	41,4	37,6	600	984	70	180	172,0		7535
FAA6303-12	560	750	495	94,3	74	46,3	42,1	600	1102	70	180	188,0		7950
FAA6304-12	630	845	495	94,4	74	52,1	47,3	600	1240	70	180	202,0		8775
FAA6305-12	710	950	495	94,5	74	58,6	53,3	600	1398	70	180	213,0		9260

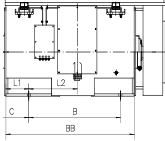

FRAME	POLE	MOUNTING									
		A	B	C	D	E	F	G	H	K1	
355	2	630±1.75	900±1.75	315±4	80 ^{+0.03} _{+0.01}	170±0.5	22 ⁰ ₋	71 ⁰ _{-0.2}	355 ⁰ ₋₁	28 ^{+0.62} ₀	
355	4~6	630±1.75	900±1.75	315±4	100 ^{+0.03} _{+0.01}	210±0.5	28 ⁰ ₋	90 ⁰ _{-0.2}	355 ⁰ ₋₁	28 ^{+0.62} ₀	
400	2	710±1.75	1000±1.75	375±4	90 ^{+0.03} _{+0.01}	170±0.5	25 ⁰ ₋	81 ⁰ _{-0.2}	400 ⁰ ₋₁	35 ^{+0.62} ₀	
400	4~8	710±1.75	1000±1.75	335±4	110 ^{+0.03} _{+0.01}	210±0.57	28 ⁰ ₋	100 ⁰ _{-0.2}	400 ⁰ ₋₁	35 ^{+0.62} ₀	
450	2	800±1.75	1120±1.75	400±4	100 ^{+0.03} _{+0.01}	210±0.57	28 ⁰ ₋	90 ⁰ _{-0.2}	450 ⁰ ₋₁	35 ^{+0.62} ₀	
450	4	800±1.75	1120±1.75	355±4	120 ^{+0.03} _{+0.01}	210±0.57	32 ⁰ ₋	109 ⁰ _{-0.2}	450 ⁰ ₋₁	35 ^{+0.62} ₀	
450	6~12	800±1.75	1120±1.75	355±4	130 ^{+0.04} _{+0.01}	250±0.57	32 ⁰ ₋	119 ⁰ _{-0.2}	450 ⁰ ₋₁	35 ^{+0.62} ₀	
500	2	900±2.1	1250±2.1	560±4	110 ^{+0.03} _{+0.01}	210±0.57	28 ⁰ ₋	100 ⁰ _{-0.2}	500 ⁰ ₋₁	42 ^{+0.62} ₀	
500	4	900±2.1	1250±2.1	475±4	130 ^{+0.04} _{+0.01}	250±0.57	32 ⁰ ₋	119 ⁰ _{-0.2}	500 ⁰ ₋₁	42 ^{+0.62} ₀	
500	6~10	900±2.1	1250±2.1	475±4	140 ^{+0.04} _{+0.01}	250±0.57	36 ⁰ ₋	128 ⁰ _{-0.3}	500 ⁰ ₋₁	42 ^{+0.62} ₀	
560	2	1000±2.1	1400±2.1	560±4	130 ^{+0.04} _{+0.01}	250±0.57	32 ⁰ ₋	119 ⁰ _{-0.2}	560 ⁰ ₋₁	42 ^{+0.62} ₀	
560	4	1000±2.1	1400±2.1	500±4	150 ^{+0.04} _{+0.01}	250±0.57	36 ⁰ ₋	138 ⁰ _{-0.3}	560 ⁰ ₋₁	42 ^{+0.62} ₀	
560	6~12	1000±2.1	1400±2.1	500±4	160 ^{+0.04} _{+0.01}	300±0.65	40 ⁰ ₋	147 ⁰ _{-0.3}	560 ⁰ ₋₁	42 ^{+0.62} ₀	
630	2	1120±2.1	1600±2.1	560±4	140 ^{+0.04} _{+0.01}	250±0.57	36 ⁰ ₋	128 ⁰ _{-0.3}	630 ⁰ ₋₁	48 ^{+0.62} ₀	
630	4	1120±2.1	1600±2.1	530±4	170 ^{+0.04} _{+0.01}	300±0.65	40 ⁰ ₋	157 ⁰ _{-0.3}	630 ⁰ ₋₁	48 ^{+0.62} ₀	
630	6~12	1120±2.1	1600±2.1	530±4	180 ^{+0.04} _{+0.01}	300±0.65	45 ⁰ ₋	165 ⁰ _{-0.3}	630 ⁰ ₋₁	48 ^{+0.62} ₀	

kV 6-6.6 MOUNTING DIMENSIONS INSTALLATION



FRAME	POLE	OUTLINE								
		AC	AD	AB	BB	HA	HD	L1	L2	L
355	2	495	760	780	1350	25	1400	189	515	2100
355	4~6	495	760	780	1400	25	1300	200	530	2100
400	2	560	900	908	1450	36	1455	249	606	2200
400	4~6	560	900	900	1510	30	1455	209	626	2241
450	2	600	926	980	1530	40	1650	287	538	2270
450	4	600	926	980	1638	32	1650	242	577	2325
450	4~12	600	926	980	1638	32	1650	242	577	2430
500	2	660	1115	1112	1720	50	2200	330	990	2920
500	4	660	1000	1112	1720	35	1805	310	669	2572
500	6~12	660	1000	1112	1720	35	1805	310	669	2572
560	2	740	1200	1216	1940	55	2500	270	1120	3400
560	4	740	1050	1216	1938	45	2120	320	755	2840
560	6~12	740	1050	1216	1938	45	2120	320	755	2890
630	2	850	1350	1396	2080	55	2900	265	1320	3430
630	4~12	825	1150	1396	2120	50	2155	365	685	3044

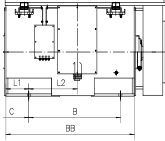

FRAME	POLE	MOUNTING										
		A	B	C	D	E	F	G	H	K1		
400	2	710±1.75	1000±1.75	375±4	80 ^{+0.03} / _{+0.01}	170±0.5	22 ⁰ / ₋	71 ⁰ / _{-0.2}	400 ⁰ / ₋₁	35 ^{+0.6} / ₀		
400	4~8	710±1.75	1000±1.75	335±4	110 ^{+0.03} / _{+0.01}	210±0.57	28 ⁰ / ₋	100 ⁰ / _{-0.2}	400 ⁰ / ₋₁	35 ^{+0.6} / ₀		
450	2	800±1.75	1120±1.75	400±4	90 ^{+0.03} / _{+0.01}	170±0.57	25 ⁰ / ₋	81 ⁰ / _{-0.2}	450 ⁰ / ₋₁	35 ^{+0.6} / ₀		
450	4~8	800±1.75	1120±1.75	355±4	110 ^{+0.03} / _{+0.01}	210±0.57	28 ⁰ / ₋	100 ⁰ / _{-0.2}	450 ⁰ / ₋₁	35 ^{+0.6} / ₀		
500	2	900±2.1	1250±2.1	560±4	100 ^{+0.03} / _{+0.01}	210±0.57	28 ⁰ / ₋	90 ⁰ / _{-0.2}	500 ⁰ / ₋₁	42 ^{+0.6} / ₀		
500	4	900±2.1	1250±2.1	475±4	120 ^{+0.04} / _{+0.01}	210±0.57	32 ⁰ / ₋	109 ⁰ / _{-0.2}	500 ⁰ / ₋₁	42 ^{+0.6} / ₀		
500	6~12	900±2.1	1250±2.1	475±4	130 ^{+0.04} / _{+0.01}	250±0.57	32 ⁰ / ₋	119 ⁰ / _{-0.3}	500 ⁰ / ₋₁	42 ^{+0.6} / ₀		
560	2	1000±2.1	1400±2.1	560±4	130 ^{+0.04} / _{+0.01}	250±0.57	32 ⁰ / ₋	119 ⁰ / _{-0.2}	560 ⁰ / ₋₁	42 ^{+0.6} / ₀		
560	4	1000±2.1	1400±2.1	500±4	150 ^{+0.04} / _{+0.01}	250±0.57	36 ⁰ / ₋	138 ⁰ / _{-0.3}	560 ⁰ / ₋₁	42 ^{+0.6} / ₀		
560	6~12	1000±2.1	1400±2.1	500±4	160 ^{+0.04} / _{+0.01}	300±0.65	40 ⁰ / ₋	147 ⁰ / _{-0.3}	560 ⁰ / ₋₁	42 ^{+0.6} / ₀		
630	2	1120±2.1	1600±2.1	560±4	140 ^{+0.04} / _{+0.01}	250±0.57	36 ⁰ / ₋	128 ⁰ / _{-0.3}	630 ⁰ / ₋₁	48 ^{+0.6} / ₀		
630	4	1120±2.1	1600±2.1	530±4	170 ^{+0.04} / _{+0.01}	300±0.65	40 ⁰ / ₋	157 ⁰ / _{-0.3}	630 ⁰ / ₋₁	48 ^{+0.6} / ₀		
630	6~12	1120±2.1	1600±2.1	530±4	180 ^{+0.04} / _{+0.01}	300±0.65	45 ⁰ / ₋	165 ⁰ / _{-0.3}	630 ⁰ / ₋₁	48 ^{+0.6} / ₀		

kV 10-11 MOUNTING DIMENSIONS INSTALLATION



FRAME	POLE	OUTLINE								
		AC	AD	AB	BB	HA	HD	L1	L2	L
400	2	560	900	908	1450	36	1455	249	606	2200
400	4~6	560	900	900	1510	30	1455	209	626	2241
450	2	605	934	1000	1530	40	1650	250	515	2175
450	4~8	600	926	980	1638	32	1650	242	577	2325
500	2									
500	4	660	1000	1112	1720	35	1805	310	669	2532
500	6~12	660	1000	1112	1720	35	1805	310	669	2572
560	2									
560	4	740	1050	1216	1938	45	2120	320	755	2840
560	6~12	740	1050	1216	1938	45	2120	320	755	2890
630	2									
630	4~12	825	1150	1396	2120	50	2155	365	685	3044

CONTACTS

Head Quarter

FELM srl

Via Morandi (Industrial Area)

20010 Inveruno (Mi) Italy

Tel. +39 02 97 289 454

Tel. +39 02 97 288 320

Fax +39 02 97 289 923

E-mail home@felm.it

FELM Office Germany

Heinrich-Busold-Strasse 47

D-61169 Friedberg (Hessen), Germany

Tel (Off): +49-6031-721606

Mobile: +49-172-6729011

Fax: +49-6031-721610

Email: Jayant@jk-conrep.de

FELM Office China

Add: Room 1002, Building 3#,

No 139 Rd. SongShan,

Jianye, Nanjing, Jiangsu, China

Fax: +86-25-87797622

Tel: +86-15077829999

Email: lidongming1974@vip.sina.com

FELM Office Middle East

Al Saalam Street, Al Darwish Building (NBAD building)

office no. 1403 Abu Dhabi (United Arab Emirates) P.O. Box 45223

Office Ph. + 971-2-6710330

Office Fax + 971-2-6710255

mobile +971 50 4442093

Email: ayman.abdallah@felm.it

FELM Office UK

The Foundry, Wadebridge

Cornwall, PL277PG

United Kingdom

Tel (Off): +441208 816543

Mobile: +447791717488

Email: Toby@felm.co.uk

WORLD WIDE SERVICE

Mobile +39 355 69 53 804

E-mail service@felm.it





MEDIUM & HIGH VOLTAGE

HIGH EFFICIENCY – BIGGER POWER



GENERAL CHARACTERISTICS

The designing, manufacturing and testing of squirrel cage induction motors made by Felm® are according with IEC standard, Felm supply high quality cast iron motors with high performance and flexibility top meet the customer request they are widely used in various industries, mining, pumps, compressors, wind machineries, fans ect.

Compact Series Motors Technical details:

Efficiency level: High efficiency level

Number of Poles: 2 up to 8

Frequency: 50 Hz.

(Optional: 60 Hz.)

Voltage: 6 kV. – 10 kV.

(Optional: other rated voltages 3-3.3-6.6-11 kV.)

Frames: 315 up to 560

Cast iron frame

Cooling system: IC411

(Options: IC416 Inverter use rated 1:10)

Die cast Aluminum Rotor

Color: RAL 5010 (Blue)

(Options: Others type of colour)

VPI Insulation System

Insulation class F (class B temperature rise)

(Options: Class H)

PT100 in the windings and bearings

Degree of protection: IP55

(Options: IP56 - IP65)

Mounting: B3

(Options: B35 - V1)

Painting plan:

(Options: Marine - Chemical - Munsell)

Internal epoxy coating (tropicalized)

Sintered drain plug

Terminal block on side (right view from the shaft)

Shaft Material: C45

Double grounding (1 inside terminal box + 2 on the frame)

Grease Caltex SRI-2 or SKF LGHP2

(Different types recommended by Felm)

Regreasing system for frames 315 up to 560

Options:

PT100 in the winding connected in separate auxiliary terminal box

PT100 on the bearings connected in separate auxiliary terminal box

Space Heaters connected in separate auxiliary terminal box

Predisposition and All type of Encoder

Special shaft materials

DC or AC Brake

Motor Type		Rated Power		Rated Speed	Efficiency	Power Factor	Current		Torque			Moment of inertia (J)	Weight Approx
							Full Load 6kV	Locked Rotor	Full Load	Locked Rotor	Pull Out		
		kW	(HP)	RPM	%	%	A	%FLC	kg-m	%FLT	%FLT	kg-m ²	Kg
FHV	355 1-2	185	250	2980	93,5	84,0	22,7	700	60	70	200	2.6	1900
FHV	355 2-2	200	270	2980	94,0	84,0	24,4	700	65	70	200	2.8	2000
FHV	355 3-2	220	295	2980	94,2	84,0	26,8	700	72	70	200	3.0	2100
FHV	355 3-2	250	335	2980	94,4	84,0	30,3	700	82	70	200	3.3	2200
FHV	355 5-2	280	375	2980	94,6	86,0	33,1	700	92	70	200	3.5	2350
FHV	400 1-2	315	420	2980	94,8	86,0	37,2	700	103	70	200	5.0	2900
FHV	400 2-2	355	475	2980	94,9	86,0	41,9	700	116	70	200	5.5	3000
FHV	400 3-2	400	535	2980	95,1	86,0	47,1	700	131	70	200	6.0	3100
FHV	400 4-2	450	605	2980	95,2	86,0	52,9	700	147	70	200	7.0	3200
FHV	450 1-2	500	670	2982	95,3	87,0	58,0	700	163	70	200	11	3500
FHV	450 2-2	560	750	2982	95,4	87,0	64,9	700	183	70	200	12	3600
FHV	450 3-2	630	845	2982	95,5	87,0	73,0	700	206	70	200	13	3700
FHV	450 4-2	710	950	2982	95,6	87,0	82,1	700	232	70	200	14	3850
FHV	500 1-2	800	1070	2982	95,7	88,0	91,4	700	261	70	200	17	5780
FHV	500 2-2	900	1205	2982	95,8	88,0	102,7	700	294	70	200	19	6050
FHV	500 3-2	1000	1340	2982	95,9	88,0	114,0	700	327	70	200	21	6320
FHV	500 4-2	1120	1500	2982	96,0	88,0	127,6	700	366	70	200	23	6600
FHV	355 1-4	185	250	1485	93,1	84,0	22,8	650	121	80	200	6,0	1900
FHV	355 2-4	200	270	1485	93,9	84,0	24,4	650	131	80	200	7.0	2000
FHV	355 3-4	220	295	1485	94,1	84,0	26,8	650	144	80	200	8.0	2100
FHV	355 4-4	250	335	1485	94,3	84,0	30,4	650	164	80	200	9.0	2200
FHV	355 5-4	280	375	1485	94,5	84,0	33,9	650	184	80	200	10	2300
FHV	400 1-4	315	420	1485	94,6	85,0	37,7	650	207	80	200	11	3000
FHV	400 2-4	355	475	1485	94,8	85,0	42,4	650	233	80	200	12	3100
FHV	400 3-4	400	535	1485	95,0	85,0	47,7	650	262	80	200	13	3200
FHV	400 4-4	450	605	1485	95,2	85,0	53,5	650	295	80	200	14	3300
FHV	450 1-4	500	670	1485	95,3	86,0	58,7	650	328	80	200	22	3600
FHV	450 2-4	560	750	1485	95,4	86,0	65,7	650	367	80	200	24	3700
FHV	450 3-4	630	845	1485	95,5	86,0	73,8	650	413	80	200	26	3800
FHV	450 4-4	710	950	1485	95,6	86,0	83,1	650	466	80	200	28	3950
FHV	500 1-4	800	1070	1488	95,7	86,0	93,5	650	524	80	200	41	5820
FHV	500 2-4	900	1210	1488	95,8	86,0	105,1	650	589	80	200	44	6100
FHV	500 3-4	1000	1340	1488	95,9	86,0	116,7	650	655	80	200	47	6280
FHV	500 4-4	1120	1500	1488	96,0	86,0	130,5	650	733	80	200	50	6420
FHV	560 1-4	1250	1680	1488	96,1	87,0	143,9	650	819	70	200	70	8020
FHV	560 2-4	1400	1880	1488	96,2	87,0	161,0	650	917	70	200	74	8390
FHV	560 3-4	1600	2140	1488	96,4	87,0	183,6	650	1048	70	200	78	8750
FHV	560 4-4	1800	2410	1488	96,5	87,0	206,3	650	1179	70	200	82	9100

Different power, frame and pole on request.

Technical data kV. 6 6 pole – 8 pole



Motor Type		Rated Power		Rated Speed	Efficiency	Power Factor	Current		Torque			Moment of inertia (J)	Weight Approx
							Full Load 6kV	Locked Rotor	Full Load	Locked Rotor	Pull Out		
		kW	(HP)	RPM	%	%	A	%FLC	kg-m	%FLT	%FLT	kg-m ²	Kg
FHV	400 2-6	250	335	988	93,9	82,0	31,2	600	247	80	200	16	3000
FHV	400 3-6	280	375	988	94,1	82,0	34,9	600	276	80	200	18	3200
FHV	400 4-6	315	420	988	94,3	82,0	39,2	600	311	80	200	20	3400
FHV	450 1-6	355	475	988	94,5	83,0	43,6	600	350	80	200	28	3500
FHV	450 2-6	400	535	988	94,6	83,0	49,0	600	395	80	200	30	3600
FHV	450 3-6	450	605	988	94,7	83,0	55,1	600	444	80	200	32	3700
FHV	450 4-6	500	670	988	94,9	83,0	61,1	600	493	80	200	34	3820
FHV	500 1-6	560	750	990	95,1	83,0	68,3	600	551	80	200	54	5610
FHV	500 2-6	630	845	990	95,2	83,0	76,7	600	620	80	200	58	5790
FHV	500 3-6	710	950	990	95,3	83,0	86,4	600	699	80	200	62	6010
FHV	500 4-6	800	1070	990	95,4	83,0	97,2	600	787	80	200	66	6230
FHV	560 1-6	900	1210	990	95,6	84,0	107,8	600	886	70	200	94	7650
FHV	560 2-6	1000	1340	990	95,7	84,0	119,7	600	984	70	200	102	7950
FHV	560 3-6	1120	1500	990	95,8	84,0	133,9	600	1102	70	200	110	8250
FHV	560 4-6	1250	1680	990	95,9	84,0	149,3	600	1230	70	200	118	8550
FHV	400 1-8	160	215	738	93,2	76,0	21,7	550	211	80	200	15	3000
FHV	400 2-8	185	250	738	93,3	76,0	25,1	550	244	80	200	16	3100
FHV	400 3-8	200	270	738	93,5	77,0	26,7	550	264	80	200	18	3200
FHV	400 4-8	220	295	738	93,7	77,0	29,3	550	290	80	200	20	3300
FHV	450 1-8	250	335	740	93,9	78,0	32,8	550	329	80	200	28	3500
FHV	450 2-8	280	375	740	94,1	78,0	36,7	550	369	80	200	30	3600
FHV	450 3-8	315	420	740	94,2	78,0	41,3	550	415	80	200	32	3700
FHV	450 4-8	355	475	740	94,4	78,0	46,4	550	467	80	200	34	3820
FHV	500 1-8	400	535	742	94,5	79,0	51,6	550	525	80	200	54	5250
FHV	500 2-8	450	605	742	94,6	79,0	57,9	550	591	80	200	58	5490
FHV	500 3-8	500	670	742	94,8	80,0	63,4	550	657	80	200	62	5750
FHV	500 4-8	560	750	742	94,9	80,0	71,0	550	735	80	200	66	6020
FHV	560 1-8	630	845	745	95,1	81,0	78,7	550	824	70	200	96	7000
FHV	560 2-8	710	950	745	95,3	81,0	88,5	550	929	70	200	105	7350
FHV	560 3-8	800	1070	745	95,4	81,0	99,6	550	1046	70	200	110	7700
FHV	560 4-8	900	1210	745	95,6	81,0	111,8	550	1177	70	200	116	8100

Different power, frame and pole on request.



Technical data kV. 10 2 pole – 4 pole

Motor Type		Rated Power		Rated Speed	Efficiency	Power Factor	Current		Torque			Moment of inertia (J)	Approx WT	Noise level (Approx)
							Full Load 10kV	Locked Rotor	Full Load	Locked Rotor	Pull Out			
		kW	(HP)	RPM	%	%	A	%FLC	kg-m	%FLT	%FLT	kg-m ²	Kg	dB(A)
FHV	400 1-2	220	295	2980	93,2	84	16,2	700	72	70	200	5.0	2900	84
FHV	400 2-2	250	335	2980	93,3	84	18,4	700	82	70	200	5.5	3000	86
FHV	400 3-2	280	375	2980	93,5	85	20,3	700	92	70	200	6.0	3100	86
FHV	400 4-2	315	420	2980	93,8	85	22,8	700	103	70	200	7.0	3200	86
FHV	450 1-2	355	475	2982	94,3	86	25,3	700	116	70	200	11	3500	86
FHV	450 2-2	400	535	2982	94,4	86	28,4	700	131	70	200	12	3600	86
FHV	450 3-2	450	605	2982	94,5	86	32,0	700	147	70	200	13	3700	86
FHV	450 4-2	500	670	2982	94,8	86	35,4	700	163	70	200	14	3850	86
FHV	500 1-2	560	750	2985	95,0	87	39,1	700	183	70	200	15	5500	86
FHV	500 2-2	630	845	2985	95,2	87	43,9	700	206	70	200	17	5780	88
FHV	500 3-2	710	950	2985	95,3	87	49,4	700	232	70	200	19	6050	88
FHV	500 4-2	800	1070	2985	95,5	88	55,0	700	261	70	200	21	6320	88
FHV	500 5-2	900	1210	2985	95,8	88	61,6	700	294	70	200	23	6600	89
FHV	400 1-4	220	295	1482	93,5	84	16,2	650	145	80	200	11	3000	83
FHV	400 2-4	250	335	1482	93,8	84	18,3	650	164	80	200	12	3100	85
FHV	400 3-4	280	375	1482	94,0	84	20,5	650	184	80	200	13	3200	85
FHV	400 4-4	315	420	1482	94,2	84	23,0	650	207	80	200	14	3300	85
FHV	450 1-4	355	475	1485	94,5	85	25,5	650	233	80	200	20	3500	85
FHV	450 2-4	400	535	1485	94,8	85	28,7	650	262	80	200	22	3600	85
FHV	450 3-4	450	605	1485	95,0	85	32,2	650	295	80	200	24	3700	85
FHV	450 4-4	500	670	1485	95,2	86	35,3	650	328	80	200	26	3800	85
FHV	450 5-4	560	750	1485	95,3	86	39,5	650	367	80	200	28	3950	85
FHV	500 1-4	630	845	1488	95,4	86	44,3	650	413	80	200	41	5820	87
FHV	500 2-4	710	950	1488	95,5	86	49,9	650	465	80	200	44	6100	87
FHV	500 3-4	800	1070	1488	95,6	87	55,5	650	524	80	200	47	6280	87
FHV	500 4-4	900	1210	1488	95,7	87	62,4	650	589	80	200	50	6420	87
FHV	560 1-4	1000	1340	1488	95,8	86	70,1	650	655	70	200	70	8020	88
FHV	560 2-4	1120	1500	1488	95,9	86	78,4	650	733	70	200	74	8390	88
FHV	560 3-4	1250	1680	1488	96,0	87	86,4	650	819	70	200	78	8750	89
FHV	560 4-4	1400	1880	1488	96,1	87	96,7	650	917	70	200	82	9100	89

Technical data kV. 10 6 pole – 8 pole



Motor Type	Rated Power		Rated Speed	Efficiency	Power Factor	Current		Torque			Moment of inertia (J)	Approx WT	Noise level (Approx)
	kW	(HP)	RPM	%	%	Full Load 10kV	Locked Rotor	Full Load	Locked Rotor	Pull Out			
						A	%FLC	kg-m	%FLT	%FLT	kg-m ²	Kg	dB(A)
FHV 450 5-6	355	475	985	94,3	82	26,5	600	351	80	200	34	3820	81
FHV 500 1-6	400	535	985	94,4	83	29,5	600	396	80	200	50	5450	81
FHV 500 2-6	450	605	988	94,6	83	33,1	600	444	80	200	54	5610	81
FHV 500 3-6	500	670	988	94,8	83	36,7	600	493	80	200	58	5790	81
FHV 500 4-6	560	750	990	95,0	83	41,0	600	551	80	200	62	6010	81
FHV 500 5-6	630	845	990	95,1	83	46,1	600	620	80	200	66	6230	83
FHV 560 1-6	710	950	992	95,3	83	51,8	600	697	70	200	87	7400	83
FHV 560 2-6	800	1070	992	95,4	83	58,3	600	786	70	200	94	7650	83
FHV 560 3-6	900	1210	992	95,5	84	64,8	600	884	70	200	102	7950	83
FHV 560 4-6	1000	1340	992	95,6	84	71,9	600	982	70	200	110	8250	83
FHV 560 5-6	1120	1500	992	95,7	84	80,4	600	1100	70	200	118	8550	83
FHV 450 1-8	220	295	740	93,6	78	17,4	550	290	80	200	30	3600	75
FHV 450 2-8	250	335	740	93,8	78	19,7	550	329	80	200	32	3700	77
FHV 450 3-8	280	375	740	94,0	78	22,0	550	369	80	200	34	3820	77
FHV 500 1-8	315	420	742	94,2	78	24,8	550	414	80	200	54	5250	77
FHV 500 2-8	355	475	742	94,4	78	27,8	550	466	80	200	58	5490	77
FHV 500 3-8	400	535	742	94,5	79	30,9	550	525	80	200	62	5750	77
FHV 500 4-8	450	605	742	94,6	79	34,8	550	591	80	200	66	6020	77
FHV 560 1-8	500	670	745	94,7	80	38,1	550	654	70	200	88	6650	77
FHV 560 2-8	560	750	745	94,8	80	42,6	550	733	70	200	96	7000	81
FHV 560 3-8	630	845	745	95,0	81	47,3	550	824	70	200	105	7350	81
FHV 560 4-8	710	950	745	95,2	81	53,2	550	929	70	200	110	7700	81
FHV 560 5-8	800	1070	745	95,3	81	59,8	550	1046	70	200	116	8100	81

Different power, frame and pole on request.

DIMENSIONS



B3

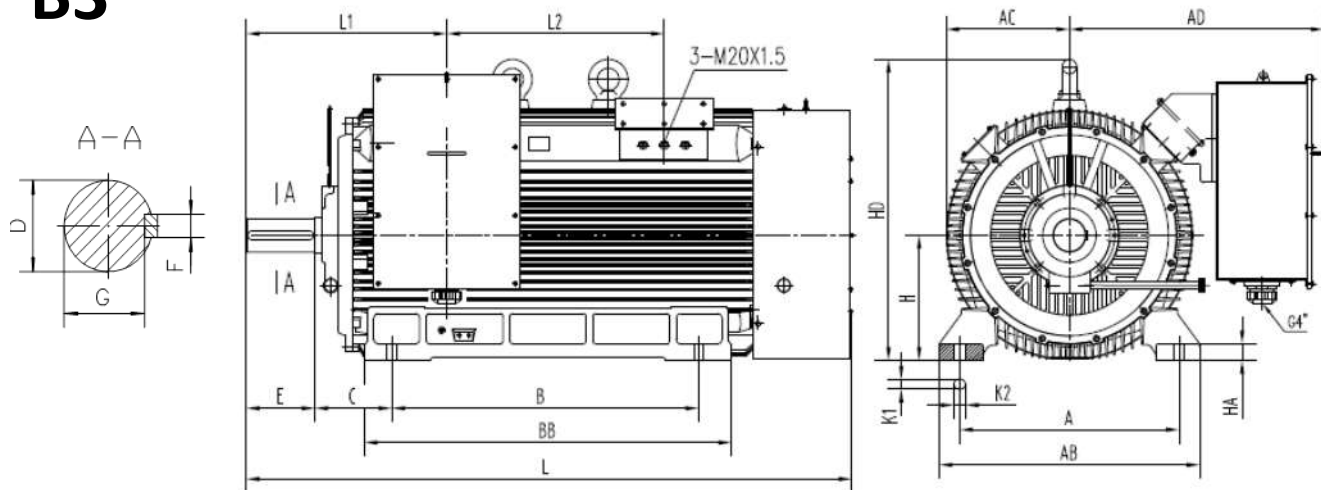

Frame	Pole	MOUNTING									
		A	B	C	D	E	F	G	H	K	
315	2	560±1.4	800±1.4	216±4	65 ^{+0.03} _{+0.01}	140±0.5	18 ⁰ _{-0.043}	58 ⁰ _{-0.2}	315 ⁰ ₋₁	28 ^{+0.5} ₀	
315	4	560±1.4	800±1.4	216±4	80 ^{+0.03} _{+0.01}	170±0.5	22 ⁰ _{-0.052}	71 ⁰ _{-0.2}	315 ⁰ ₋₁	28 ^{+0.5} ₀	
355	2	630±1.4	900±1.4	254±4	75 ^{+0.03} _{+0.01}	140±0.5	20 ⁰ _{-0.052}	67,5 ⁰ _{-0.2}	355 ⁰ ₋₁	28 ^{+0.5} ₀	
355	4~6	630±1.4	900±1.4	254±4	100 ^{+0.03} _{+0.01}	210±0.57	28 ⁰ _{-0.052}	90 ⁰ _{-0.2}	355 ⁰ ₋₁	28 ^{+0.5} ₀	
400	2	710±1.75	1000±1.75	280±4	85 ^{+0.03} _{+0.01}	170±0.5	22 ⁰ _{-0.052}	76 ⁰ _{-0.2}	400 ⁰ ₋₁	35 ^{+0.6} ₀	
400	4~8	710±1.75	1000±1.75	280±4	110 ^{+0.03} _{+0.01}	210±0.57	28 ⁰ _{-0.052}	100 ⁰ _{-0.2}	400 ⁰ ₋₁	35 ^{+0.6} ₀	
450	2	800±1.75	1120±1.75	280±4	95 ^{+0.03} _{+0.01}	170±0.5	25 ⁰ _{-0.052}	86 ⁰ _{-0.2}	450 ⁰ ₋₁	35 ^{+0.6} ₀	
450	4	800±1.75	1120±1.75	280±4	120 ^{+0.03} _{+0.01}	210±0.57	32 ⁰ _{-0.062}	109 ⁰ _{-0.2}	450 ⁰ ₋₁	35 ^{+0.6} ₀	
450	6~8	800±1.75	1120±1.75	280±4	130 ^{+0.04} _{+0.01}	250±0.57	32 ⁰ _{-0.062}	119 ⁰ _{-0.2}	450 ⁰ ₋₁	35 ^{+0.6} ₀	
500	4	900±2.1	1250±2.1	315±4	130 ^{+0.04} _{+0.01}	250±0.57	32 ⁰ _{-0.062}	119 ⁰ _{-0.2}	500 ⁰ ₋₁	42 ^{+0.6} ₀	
500	6~8	900±2.1	1250±2.1	315±4	140 ^{+0.04} _{+0.01}	250±0.57	36 ⁰ _{-0.062}	128 ⁰ _{-0.3}	500 ⁰ ₋₁	42 ^{+0.6} ₀	
560	4	1000±2.1	1400±2.1	355±4	150 ^{+0.04} _{+0.01}	250±0.57	36 ⁰ _{-0.062}	138 ⁰ _{-0.3}	560 ⁰ ₋₁	42 ^{+0.6} ₀	
560	6~8	1000±2.1	1400±2.1	355±4	160 ^{+0.04} _{+0.01}	300±0.65	40 ⁰ _{-0.062}	147 ⁰ _{-0.3}	560 ⁰ ₋₁	42 ^{+0.6} ₀	

Frame	Pole	OUTLINE								
		AC	AD	AB	BB	HA	HD	L1	L2	L
315	2	350	760	680	1080	45	785	482	797	1740
315	4	350	760	680	1080	45	785	512	797	1770
355	2	400	785	760	1140	50	995	491	841	1800
355	4~6	400	785	760	1140	50	995	561	841	1870
400	2	445	920	870	1200	50	980	662	700	2000
400	4~8	445	920	870	1200	50	980	702	700	2040
450	2	500	950	980	1495	50	1140	670	921	2360
450	4	500	950	980	1495	50	1140	710	921	2400
450	6~8	500	950	980	1495	50	1140	750	921	2440
500	4~8	550	1010	1080	1600	65	1220	786	980	2530
560	4	610	1030	1170	1680	76	1480	812	970	2650
560	6~8	610	1030	1170	1680	76	1480	862	970	2700

frame 500, 560 2 pole and V1, B3/B5 drawings on demand.

Bearings (IMB3)

F2-HV (6 kV)			F2-HV (10 kV)		
315-2	6317C3	6317C3			
315-4.6.8	6319C3	6319C3			
355-2	6318C3	6318C3			
355-4.6.8	6322C3	6322C3			
400-2	6220C3	6220C3	400-2	6220C3	6220C3
400-4.6.8	6326C3	6326C3	400-4	6326C3	6326C3
450-2	6221C3	6221C3	450-2	6221C3	6221C3
450-4.6.8	6328C3	6328C3	450-4.6.8	6328C3	6328C3
500-2	on demand	on demand	500-2	on demand	on demand
500-4	6328C3	6328C3	500-4.6.8	6328C3	6328C3
500-6.8	6330C3	6330C3			
560-2	on demand	on demand	560-2	on demand	on demand
560-4.6.8	6334C3	6330C3	560-4.6.8	6334C3	6330C3

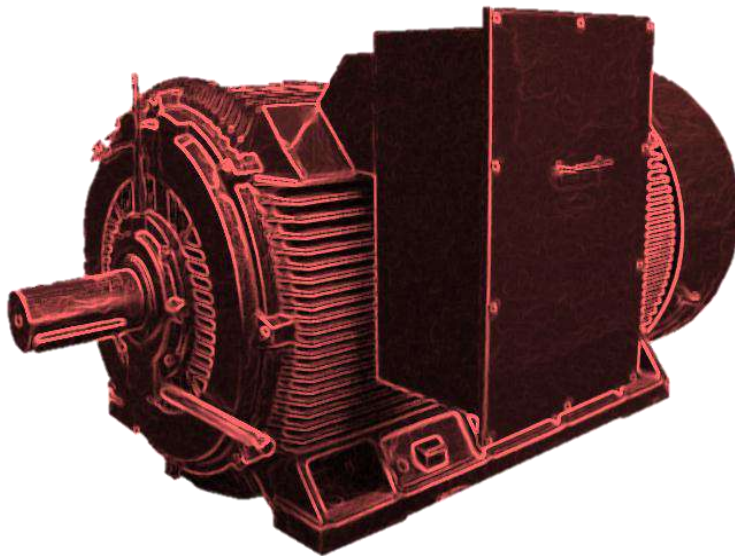

Tutti i dati (tecnici, dimensionali, ecc.) riportati nelle tabelle sono indicativi e non impegnativi. I valori garantiti vengono rilasciati su richiesta. Con l'obiettivo di un continuo sviluppo del Prodotto Motore Elettrico, FELM srl si riserva il diritto di modificare il progetto, le caratteristiche tecniche e dimensionali in qualsiasi momento senza preavviso.

All data (technical, dimensions, etc..) listed in the tables are indicative and not binding. The guaranteed values are upon request. Felm srl reserves the right to change the project, the technical characteristics and dimensions at any time without previous notice.

Terminal box kv. 6

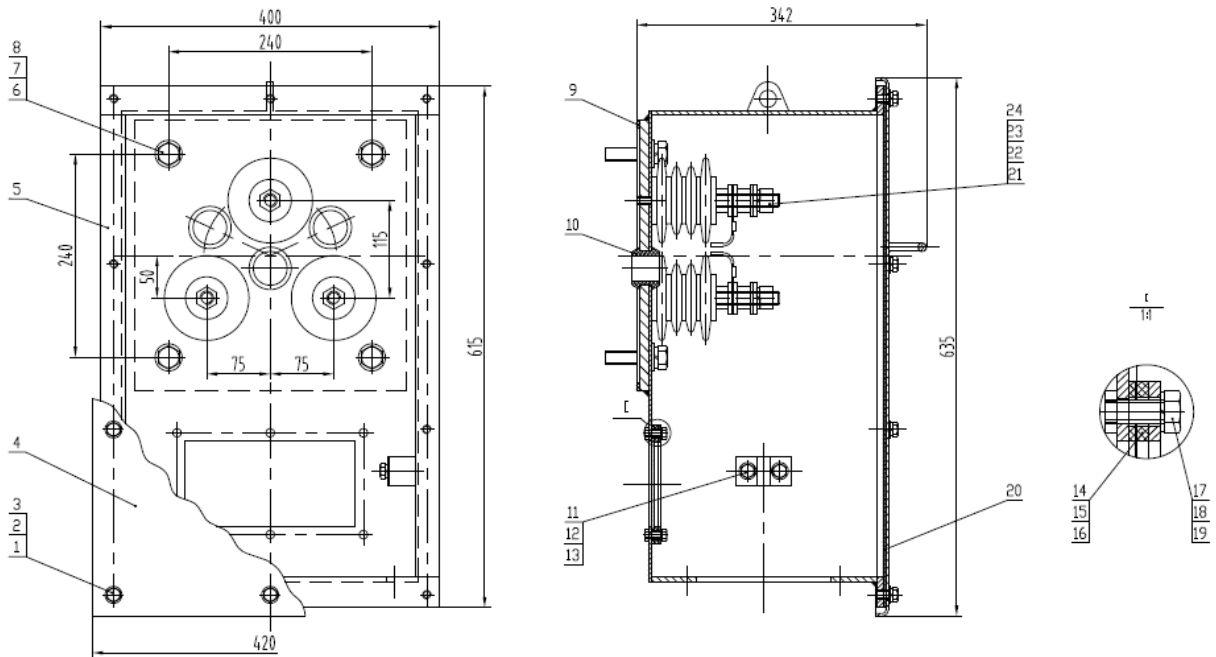

No.	Name	Type	No.	Name	Type	No.	Name	Type
1	Grouding		11	Bolt	M10x20	21	Sealing gasket	
2	Gasket 12		12	Gasket 10		22	Cover plate	
3	Gasket 12		13	Rubber gasket		23	Pressing plate	
4	Bolt	M12x25	14	Cover plat		24	Rubber gasket	
5	Bolt	M16x55	15	Gasket 16		25	Sealing gasket	
6	Gasket 16		16	Gasket 16		26	Outlet cover plate	
7	Outlet line protection sleeve		17	Nut 16		27	Barrel	G4"
8	Post isulator		18	Gasket 8				
9	Sealinfg gasket		19	Gasket 8				
10	Terminal box base		20	Bolt	M8x25			

Terminal box kV. 10

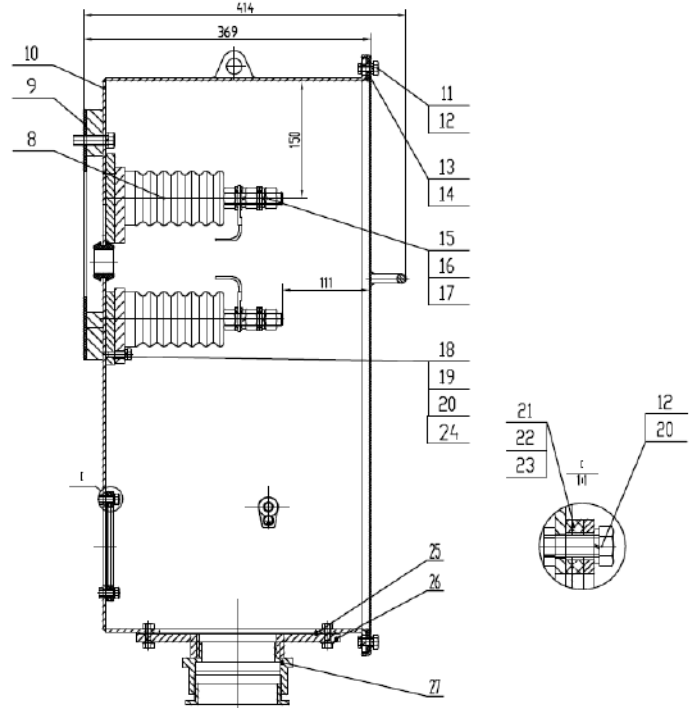
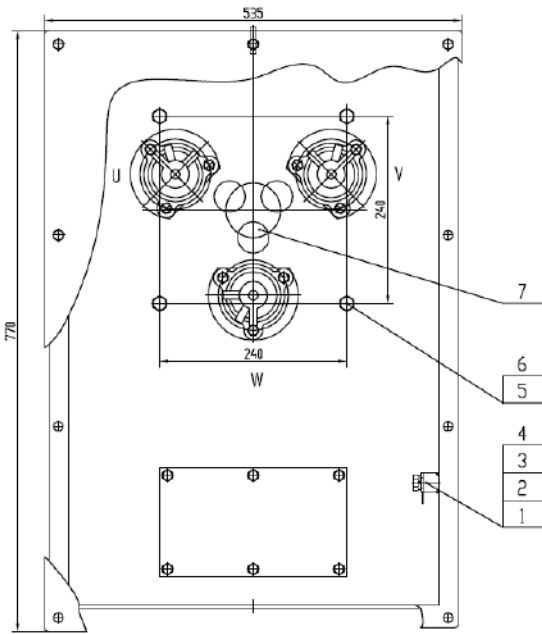

No.	Name	Type	No.	Name	Type	No.	Name	Type
1	Grouding		11	Bolt	M10x20	21	Sealing gasket	
2	Gasket 12		12	Gasket 10		22	Cover plate	
3	Gasket 12		13	Rubber gasket		23	Pressing plate	
4	Bolt	M12x25	14	Cover plat		24	Rubber gasket	
5	Bolt	M16x55	15	Gasket 16		25	Sealing gasket	
6	Gasket 16		16	Gasket 16		26	Outlet cover plate	
7	Outlet line protection sleeve		17	Nut 16		27	Barrel	G4"
8	Post isulator		18	Gasket 8				
9	Sealinfg gasket		19	Gasket 8				
10	Terminal box base		20	Bolt	M8x25			

CONTATCS

Head Quarter

FELM srl

Via Morandi (Industrial Area)

20010 Inveruno (Mi) Italy

Tel. +39 02 97 289 454

Tel. +39 02 97 288 320

Fax +39 02 97 289 923

E-mail home@felm.it



FELM Office Germany

Heinrich-Busold-Strasse 47

D-61169 Fridberg (Hessen), Germany

Tel. (Off.) +49 6331 721606

Mobile +49 172 6729011

E-mail Jayant@jk-conrep.de

FELM Office China

Room 1002, Building 3#, No.139 Rd. SongShan

Jianye, Nanjing, Jiangsu, China

Te. +86 150 778 29 999

Fax +86 25 87 797 622

E-mail lidongming1974@vip.sina.com

FELM Office Middle East

Al Saalam Street, Al Darwish Building (NBAD building)

office no. 1403 Abu Dhabi (United Arab Emirates)

P.O. Box 45223

Office Ph. + 971-2-6710330

Office Fax + 971-2-6710255

mobile +971 50 4442093

WORLD WIDE SERVICE

Mobile +39 355 69 53 804

E-mail service@felm.it





Electric Motors High Efficiency Saudi Arabia – Hz.50/60

IE3

PREMIUM EFFICIENCY





GENERAL CHARACTERISTICS

The design, manufacturing and testing of squirrel cage induction motors made by Felm® are in accordance to IEC standard, Felm supply high quality steel frame motors with high performance and flexibility to meet customer request. The motors are widely used in various industries like: mining, pumps, compressors, wind machineries, fans ect.

Motors Technical details:

Efficiency level: Premium IE3 Motors < 220 kW - > 2500 kW High efficiency level	
Number of Poles: 2 up to 12	
Frequency: 50 Hz.	(Optional: 60 Hz.)
Voltage: 6-6.6-11 kV	(Optional: other rated voltages)
Frames: 355 up to 630	
Steel welded frame	
Cooling system: IC611	(Options IC 616: Inverter use rated 1:10)
Copper bar Rotor	
Shaft sealing: O´Ring	
VPI Insulation System	
Insulation class F (class B temperature rise)	(Options: Class H)
Formed winding	
Degree of protection: IP55	(Options: IP56 - IP65)
Mounting: B3	(Options: V1)
Painting procedure:	According to ISO 12944 S
Final color: RAL 5010	
Internal epoxy coating (tropicalized)	
Sintered drain plug	
Terminal box on side:	Left or Right
Shaft Material: C45	
Double grounding (1 inside terminal box + 2 on the frame)	
Grease Caltex SRI-2 or SKF LGHP2	(Different types recommended by Felm)
Regreasing system	
Options:	
Space Heaters	
PT100 windings and bearings	
Transmitters	
CT's Transformer	
Surge Arrestor & Capacitor & Suppressor	
Vibration probes	
Junction box	
Predisposition and All type of Encoder	
Special shaft materials	
DC or AC Brake	

FELM® has been operating in the electric motor sector since 1960 and has a well-consolidated background in the market of electrical machines. Thanks to the considerable experience of its staff, it can guarantee a technical back-up able to satisfy the most sophisticated technical requirements, both installations and maintenance, ensuring an International Service to its customers. Our offices and warehouse cover an area of 10.000 square meters.



Felm has a large stock, motors from KW 0, 12 up to 800 kW in different speed and thank to this and to the great distribution net can guarantee a good product availability and fast delivery in all Italy and Europe.

Special attention is dedicated to the production process in the factory, from the careful selection of the materials, copper, insulation to the control of the impregnation and polymerisation processes (VPI Vacuum Pressure Impregnation).



The high levels of quality offered by FELM are proven by the ISO 9001 ICIM Certificate 2508/2: Production of standard electric motors and special motors made in accordance to customer specifications.

Commercialization of electric motors and related electrical or electronic accessories for the construction and distribution of electric motors. Bearings are specially selected to guarantee best performance and product quality and a working life above the average.



GENERAL CHARACTERISTICS

Three phase asynchronous motors of cage rotor construction are in accordance with the following standards:

IEC (International Electrotechnical Commission) 60034-1.

Electrical: IEC/EN 60034-1, IEC/EN60034-2-1, IEC 60034-8, IEC 60034-12, IEC/EN 60034-9, IEC 60034-14, IEC 60034-30

Mechanical: IEC 60072, IEC/EN 60034-5, IEC/EN 600

Unel, The UNEL rules are in accordance to the IEC int. standard

The principal characteristics are as follows:

- Robust construction in aluminium alloy or alternative cast iron up to size 132 with demontable feet.
- Frame and endshields in cast iron for sizes 160 / 560 with fixed feet. Feet, on request be supply motors with yeknical box on side
- Modern design.
- Generous starting torques.
- High efficiency ie for maximum energy saving.
- 2,4,6 pole motors meet or exceed the highest efficiency required by new IEC regulations:
IEC 60034-2-1 new rules concerning efficiency testing methods.
IEC 60034-30 new efficiency classes for motors
- Grade of Protection IP55 as standard
- Rated for continuous service - S1
- Low noise level.

The use of the best materials for the construction has allowed us to achieve motors with the optimum electrical and mechanical characteristics. The Felm standard range is ideal for arduous applications which require a high mechanical strength.

The motors are normally supplied for standard Eurovoltage supplies but on request can be produced for any non standard voltages and frequencies. In addition to Felm standard motors, the following derivatives can also be supplied:

- 2 or 3 speed motors with constant torque or fan/pump characteristics.
- forced ventilation for variable speed applications.
- motors with special tropicalisation treatment which are intended for use in humid tropical climates.
- flameproof EExd motors approved to ATEX standards.

INTERPRETATION OF MOTOR DATA (example)

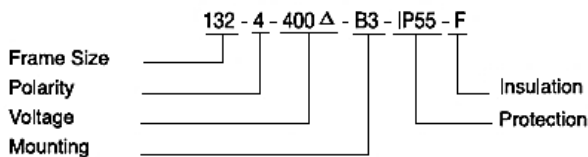

SERVICE CONDITIONS

Felm motors will operate satisfactorily in an ambient temperature range of -20°C to 40°C (class B temperature rise) and altitudes up to 1000 metres above sea level. On request it is possible to supply motors suitable for ambient temperatures and altitudes in excess of these standard conditions.

STANDARD POWER RANGE

2 pole - 0,18 ÷ 1000 KW

4 pole - 0,12 ÷ 1500 KW

6 pole - 0,06 ÷ 1500 KW

8 pole - 0,18 ÷ 1200 KW

VOLTAGE AND FREQUENCY

Standard Voltage	230 Δ / 400Δ or 400 Δ / 690Δ
Connection Δ	for outputs up to 3 KW
Connection Δ	for outputs 4 KW and above.
Frequency	50 Hz with possibility to use at 60 Hz

STATOR

The stator windings have a double impregnation treatment which solidifies to give good mechanical strength characteristics which is also highly resistant to humidity and thermal stress.

The class F insulation system with only class B temperature rise (80°C) provides an exceptional margin of safety and ensures a longer thermal life even in "abnormal" operating conditions

ROTOR

A die cast aluminium rotor is pressed or shrunk onto the shaft and dynamically balanced with half key in accordance with IEC 72.

FAN AND FANCOVER

The standard arrangement is IC411, Totally Enclosed Fan Ventilated. Cooling fans are located to the motor shaft with a key, and are designed for optimized cooling even at low speeds.

Fan covers are in sheet steel throughout the complete range.

BEARINGS

Felm motors are equipped with SKF bearings or primary brands.

Felm motors are provided with bearings adapted to the use requested, ball or roller bearings, grease lubricated.

Felm motors series FA2 (aluminium) and F2 (cast iron) frames 63 – 225 are equipped with sealed bearings (longlife), or roll bearings on request.

Felm motors serie F2 (cast iron) are equipped with ball bearings (or roll bearings on request) from frame 280 lubricated with lubricating nipples on the Drive End and on Not Drive End side.

For these bearings is necessary a periodically relubricated according to the "Installation, operation and maintenance manual" or the table on the motor.

TERMINAL BOX

For standard motors, the terminal box is mounted:

Frame 63 – 132 on the top of the motors , multi-mount for aluminium housing. Fram 160 – 450 on the top of the motors and on request on the side. The orientation shown is related looking the motor from shaft. The terminal box is equipped with cable gland and can be oriented to obtain the power input. From frame size 160 the motors are fitted with PTC, with a connection in the terminal box.



VIBRATION

Vibration of motors tested under no load conditions should not exceed the data in the following table:

Motors are balanced with half key in accordance to the IEC 60034-143

Frame size (mm)	63-132	160-225	250-355
Velocity (mm/sec)	1,8	2,8	4,5

Guaranteed values are upon request.

PROTECTION FOR TROPICAL/HOSTILE ENVIRONEMENTS

EXTERNAL SURFACES

On special request Felm can supply motors with particular treatments on the outside surface in order to resist better to humid and tropical ambient.

These motors will be painted with special paint-an enhanced form which ensures both internal and external surfaces from corrosive attack, on request we can offer inox screws.

WINDINGS

Felm motors have windings tropicalized as standard with antiflash paint.

THERMIC PROTECTION

Felm motors are equipped as standard with PTC in the winding from size 160.

On special request we can put PT100 in the windings klixon (normally closed) heaters, PT100 on the bearings

PAINTING

Felm motors are painted as standard with RAL BLUE 5010. On request it is possible to have special painting with an additional extra price.

DERATING FOR HIGH TEMPERATURE

Ambient temperature	45°C	50°C	55°C	60°C
Class B	96%	93%	87%	83%
Class F	100%	100%	100%	95%

DERATING FOR ALTITUDE

Altitude	2000m	3000m	4000m
Class B	94%	85%	75%
Class F	100%	100%	95%













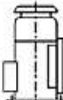
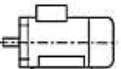

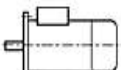
DEGREES OF PROTECTION “IP” (International Protection)

FELM motors, in standard conditions, are with protection degree IP55 in according to the current regulations.

PROTECTION AGAINST SOLID BODIES	
1 st digit	Description
0	no protect
1	protected against solid bodies of superior dimensions to 50mm
2	protected against solid bodies of superior dimensions to 12mm
3	protected against solid bodies of superior dimensions to 2,5mm
4	protected against solid bodies of superior dimensions to 1mm
5	protect against the powder
6	totally protect against the powder

PROTECTION AGAINST THE PENETRATION OF THE LIQUIDS	
2 nd digit	Description
0	no protect
1	protect against the vertical fall of water drops
2	protect against the fall of water drops with inclination max of 15°
3	protect against the rain with maximum inclination 60°
4	protect against the water sprays coming from every direction
5	protect against water jets coming from every direction
6	protect against big waves coming from every direction
7	protect against the effects of immersion to precise conditions of pressure
8	protected against the effects of the submersion to precise conditions of pressure

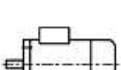
FRAME AND TYPE OF MOUNTING (IEC 60034-7)

Code I	Code II		Frame Size					Code I	Code II		Frame Size				
			63 +112	132	160 +250	280 +315	355+400				63 +112	132	160 +250	280 +315	355+400
IM B3	IM 1001	 1)	•	•	•	•	•	IM V1	IM 3011	 2)	•!	•	•	•	•
IM B35	IM 2001	 1) 2)	•	•	•	•	•	IM V15	IM 2011	 1) 2)	•!	•	•	•	•
IM B34	IM 2101	 1) 3)	•	•				IM V3	IM 3031	 2)	•	•	•	X	X
IM B5	IM 3001	 2)	•	•	•	X	X	IM V36	IM2031	 1) 2)	•	•	•	X	X
IM B6	IM 1051	 1)	•	•	•	X	X	IM V5	IM 1011	 1)	•!	•	•	X	X
IM B7	IM 1061	 1)	•	•	•	X	X	IM V6	IM 1031	 1)	•	•	•	X	X
IM B8	IM 1071	 1)	•	•	•	X	X	IM V18	IM 3611	 3)	•!	•			
IM B14	IM 3601	 3)	•	•				IM V19	IM 3631	 3)	•	•			

1. Motors with feet
2. Flanged Motor: unthreaded through holes
3. Flanged Motor: threaded dead holes

- : Available
- X: Consult Felm
- ! : Cast Iron Motors 63 frame without anti-rain canopy

For other mountings refer to IEC 60034-7.



TECHNICAL DATA ALLUMINIUM

TYPE	VA.	VA.	HZ.	Connection	kW	Amp	Amp	Eff. %	Cosφ	rpm	Weight Kg.	Duty	SF	Bearings D.E.	Bearings N.D.E.
FA3 80 K-2	230	380	50	Δ/Y	0,75	2,8	1,7	80,7	0,83	2850	18	S1	1.0	6204ZZ	6204ZZ
	230	380	60	Δ/Y	0,9	3,5	2,1	78,7	0,83	3420	18				
FA3 80 G-4	230	380	50	Δ/Y	0,75	3,0	1,8	82,5	0,76	1420	20	S1	1.0	6204ZZ	6204ZZ
	230	380	60	Δ/Y	0,9	3,7	2,2	80,5	0,76	1700	20				
FA3 90 S-6	230	380	50	Δ/Y	0,75	3,7	2,2	78,9	0,65	905	25	S1	1.0	6205ZZ	6205ZZ
	230	380	60	Δ/Y	0,9	4,5	2,7	76,9	0,65	1085	25				
FA3 80 G-2	230	380	50	Δ/Y	1,1	4,0	2,4	82,7	0,84	2860	19	S1	1.0	6204ZZ	6204ZZ
	230	380	60	Δ/Y	1,32	4,9	3,0	80,7	0,84	3430	19				
FA3 90 S-4	230	380	50	Δ/Y	1,1	4,3	2,6	84,1	0,76	1415	24	S1	1.0	6205ZZ	6205ZZ
	230	380	60	Δ/Y	1,32	5,3	3,2	82,1	0,76	1695	24				
FA3 90 L-6	230	380	50	Δ/Y	1,1	5,0	3,0	81	0,68	910	27	S1	1.0	6205ZZ	6205ZZ
	230	380	60	Δ/Y	1,32	6,2	3,7	79	0,68	1090	27				
FA3 90 S-2	230	380	50	Δ/Y	1,5	5,1	3,1	84,2	0,87	2875	24	S1	1.0	6205ZZ	6205ZZ
	230	380	60	Δ/Y	1,8	6,3	3,8	82,2	0,87	3450	24				
FA3 90 L-4	230	380	50	Δ/Y	1,5	5,7	3,4	85,3	0,78	1420	30	S1	1.0	6205ZZ	6205ZZ
	230	380	60	Δ/Y	1,8	7,0	4,2	83,3	0,78	1700	30				
FA3 100 L-6	230	380	50	Δ/Y	1,5	6,3	3,8	82,5	0,73	945	27	S1	1.0	6206ZZC3	6206ZZC3
	230	380	60	Δ/Y	1,8	7,7	4,7	80,5	0,73	1135	27				
FA3 90 L-2	230	380	50	Δ/Y	2,2	7,5	4,5	85,9	0,86	2865	27	S1	1.0	6205ZZ	6205ZZ
	230	380	60	Δ/Y	2,64	9,2	5,6	83,9	0,86	3430	27				
FA3 100 L-4	230	380	50	Δ/Y	2,2	8,1	4,9	86,7	0,79	1450	28	S1	1.0	6206ZZC3	6206ZZC3
	230	380	60	Δ/Y	2,64	9,9	6,0	84,7	0,79	1740	28				
FA3 112 M-6	230	380	50	Δ/Y	2,2	8,9	5,4	84,3	0,74	950	33	S1	1.0	6306ZZC3	6306ZZC3
	230	380	60	Δ/Y	2,5	10,3	6,2	82,3	0,74	1140	33				
FA3 100 L-2	230	380	50	Δ/Y	3	10,2	6,2	87,1	0,85	2875	24	S1	1.0	6206ZZC3	6206ZZC3
	230	380	60	Δ/Y	3,6	12,5	7,6	85,1	0,85	3450	24				
FA3 100LX-4	230	380	50	Δ/Y	3	10,7	6,5	87,7	0,8	1450	36	S1	1.0	6206ZZC3	6206ZZC3
	230	380	60	Δ/Y	3,6	13,2	8,0	85,7	0,8	1740	36				
FA3 132 S-6	230	380	50	Δ/Y	3	11,7	7,1	85,6	0,75	955	35	S1	1.0	6308ZZC3	6308ZZC3
	230	380	60	Δ/Y	3,5	14,0	8,5	83,6	0,75	1145	35				
FA3 112 M-2	380	415	50	Δ/Y	4	8,0	7,3	88,1	0,86	2890	29	S1	1.0	6306ZZC3	6306ZZC3
	380	415	60	Δ/Y	4,6	9,4	8,6	86,1	0,86	3465	29				
FA3 112 M-4	380	415	50	Δ/Y	4	8,6	7,9	88,6	0,8	1445	38	S1	1.0	6306ZZC3	6306ZZC3
	380	415	60	Δ/Y	4,6	10,1	9,2	86,6	0,8	1735	38				
FA3 132 M-6	380	415	50	Δ/Y	4	9,3	8,5	86,8	0,75	960	50	S1	1.0	6308ZZC3	6308ZZC3
	380	415	60	Δ/Y	4,6	11,0	10,1	84,8	0,75	1150	50				
FA3 132 S-2	380	415	50	Δ/Y	5,5	10,8	9,9	89,2	0,87	2890	32	S1	1.0	6308ZZC3	6308ZZC3
	380	415	60	Δ/Y	6,3	12,6	11,6	87,2	0,87	3465	32				
FA3 132 S-4	380	415	50	Δ/Y	5,5	11,4	10,4	89,6	0,82	1455	47	S1	1.0	6308ZZC3	6308ZZC3
	380	415	60	Δ/Y	6,3	13,3	12,2	87,6	0,82	1745	47				
FA3 132 MX-6	380	415	50	Δ/Y	5,5	12,5	11,4	88	0,76	960	66	S1	1.0	6308ZZC3	6308ZZC3
	380	415	60	Δ/Y	6,3	14,6	13,4	86	0,76	1150	66				
FA3 132 SX-2	380	415	50	Δ/Y	7,5	14,5	13,3	90,1	0,87	2890	40	S1	1.0	6308ZZC3	6308ZZC3
	380	415	60	Δ/Y	8,6	17,0	15,6	88,1	0,87	3465	40				
FA3 132 M-4	380	415	50	Δ/Y	7,5	15,4	14,1	90,4	0,82	1450	56	S1	1.0	6308ZZC3	6308ZZC3
	380	415	60	Δ/Y	8,6	18,0	16,5	88,4	0,82	1740	56				
FA3 160 M-6	380	415	50	Δ/Y	7,5	17,5	16,0	89,1	0,73	970	83	S1	1.0	6309ZZC3	6309ZZC3
	380	415	60	Δ/Y	8,6	20,6	18,8	87,1	0,73	1165	83				

TECHNICAL DATA CAST IRON

TYPE	VA.	VA.	H _z .	Connection	kW	Amp	Amp	Eff. %	Cosφ	rpm	Weight Kg.	Duty	SF	Bearings D.E.	Bearings N.D.E.
F3 132 M-2	380	415	50	Δ/Y	9	17,7	16,2	86,8	0,89	2880	40	S1	1.0	6308ZC3	6308ZC3
	380	415	60	Δ/Y	10,3	20,7	19,0	84,8	0,89	3455	40				
F3 160 M-2	380	415	50	Δ/Y	11	21,1	19,3	91,2	0,87	2930	92	S1	1.0	6309ZC3	6309ZC3
	380	415	60	Δ/Y	12,6	24,7	22,6	89,2	0,87	3515	92				
F3 160 M-4	380	415	50	Δ/Y	11	22,6	20,7	91,4	0,81	1470	110	S1	1.0	6309ZC3	6309ZC3
	380	415	60	Δ/Y	12,6	26,4	24,2	89,4	0,81	1765	110				
F3 160 L-6	380	415	50	Δ/Y	11	25,0	22,9	90,3	0,74	970	120	S1	1.0	6309ZC3	6309ZC3
	380	415	60	Δ/Y	12,6	29,3	26,8	88,3	0,74	1165	120				
F3 160 MX-2	380	415	50	Δ/Y	15	28,5	26,1	91,9	0,87	2930	92	S1	1.0	6309ZC3	6309ZC3
	380	415	60	Δ/Y	17,2	33,4	30,6	89,9	0,87	3515	92				
F3 160 L-4	380	415	50	Δ/Y	15	30,5	28,0	92,1	0,81	1470	123	S1	1.0	6309ZC3	6309ZC3
	380	415	60	Δ/Y	17,2	35,8	32,8	90,1	0,81	1765	123				
F3 180 L-6	380	415	50	Δ/Y	15	31,6	29,0	91,2	0,79	975	201	S1	1.0	6311ZC3	6311ZC3
	380	415	60	Δ/Y	17,2	37,1	34,0	89,2	0,79	1170	201				
F3 160 L-2	380	415	50	Δ/Y	18,5	35,0	32,0	92,4	0,87	2930	92	S1	1.0	6309ZC3	6309ZC3
	380	415	60	Δ/Y	21,2	41,0	37,5	90,4	0,87	3515	92				
F3 180 M-4	380	415	50	Δ/Y	18,5	37,0	33,9	92,6	0,82	1470	186	S1	1.0	6311ZC3	6311ZC3
	380	415	60	Δ/Y	21,2	43,4	39,7	90,6	0,82	1760	186				
F3 200 L-6	380	415	50	Δ/Y	18,5	38,8	35,5	91,7	0,79	980	243	S1	1.0	6312ZC3	6312ZC3
	380	415	60	Δ/Y	21,2	45,5	41,6	89,7	0,79	1175	243				
F3 180 M-2	380	415	50	Δ/Y	22	41,0	37,5	92,7	0,88	2950	189	S1	1.0	6311ZC3	6311ZC3
	380	415	60	Δ/Y	25,3	48,2	44,1	90,7	0,88	3540	189				
F3 180 L-4	380	415	50	Δ/Y	22	43,8	40,1	93	0,82	1470	206	S1	1.0	6311ZC3	6311ZC3
	380	415	60	Δ/Y	25,3	51,5	47,2	91	0,82	1760	206				
F3 200 LX-6	380	415	50	Δ/Y	22	46,5	42,6	92,2	0,78	980	259	S1	1.0	6312ZC3	6312ZC3
	380	415	60	Δ/Y	25,3	54,6	50,0	90,2	0,78	1175	259				
F3 200 L-2	380	415	50	Δ/Y	30	55,5	50,8	93,3	0,88	2955	242	S1	1.0	6312ZC3	6312ZC3
	380	415	60	Δ/Y	34,5	65,2	59,7	91,3	0,88	3545	242				
F3 200 L-4	380	415	50	Δ/Y	30	58,0	53,1	93,6	0,84	1475	269	S1	1.0	6312ZC3	6312ZC3
	380	415	60	Δ/Y	34,5	68,1	62,4	91,6	0,84	1770	269				
F3 225 M-6	380	415	50	Δ/Y	30	59,8	54,8	92,9	0,82	985	333	S1	1.0	6313ZC3	6313ZC3
	380	415	60	Δ/Y	34,5	70,3	64,4	90,9	0,82	1180	333				
F3 200 LX-2	380	415	50	Δ/Y	37	69,0	63,1	93,7	0,87	2955	414	S1	1.0	6312ZC3	6312ZC3
	380	415	60	Δ/Y	42,55	81,0	74,2	91,7	0,87	3545	414				
F3 225 S-4	380	415	50	Δ/Y	37	70,4	64,5	93,9	0,85	1480	473	S1	1.0	6313ZC3	6313ZC3
	380	415	60	Δ/Y	42,55	82,8	75,8	91,9	0,85	1775	473				
F3 250 M-6	380	415	50	Δ/Y	37	71,7	65,7	93,3	0,84	985	410	S1	1.0	6314C3	6314C3
	380	415	60	Δ/Y	42,55	84,3	77,2	91,3	0,84	1180	410				
F3 225 M-2	380	415	50	Δ/Y	45	81,7	74,8	94	0,89	2960	328	S1	1.0	6313ZC3	6313ZC3
	380	415	60	Δ/Y	51,75	96,0	87,9	92	0,89	3550	328				
F3 225 M-4	380	415	50	Δ/Y	45	85,4	78,2	94,2	0,85	1480	314	S1	1.0	6313ZC3	6313ZC3
	380	415	60	Δ/Y	51,75	100,3	91,9	92,2	0,85	1775	314				
F3 280 S-6	380	415	50	Δ/Y	45	86,9	79,5	93,7	0,84	990	586	S1	1.0	6317C3	6317C3
	380	415	60	Δ/Y	51,75	102,1	93,5	91,7	0,84	1185	586				
F3 250 M-2	380	415	50	Δ/Y	55	100,7	92,2	94,3	0,88	2965	414	S1	1.0	6314C3	6314C3
	380	415	60	Δ/Y	63,25	118,3	108,3	92,3	0,88	3555	414				
F3 250 M-4	380	415	50	Δ/Y	55	103,9	95,2	94,6	0,85	1480	473	S1	1.0	6314C3	6314C3
	380	415	60	Δ/Y	63,25	122,1	111,8	92,6	0,85	1775	473				
F3 280 M-6	380	415	50	Δ/Y	55	105,7	96,8	94,1	0,84	990	665	S1	1.0	6317C3	6317C3
	380	415	60	Δ/Y	63,25	124,2	113,7	92,1	0,84	1185	665				



TECHNICAL DATA CAST IRON

TYPE	VA.	VA.	H _z .	Connection	kW	Amp	Amp	Eff. %	Cosφ	rpm	Weight Kg.	Duty	SF	Bearings D.E.	Bearings N.D.E.
F3 280 S-2	380	415	50	Δ/Y	75	136,7	125,2	94,7	0,88	2975	541	S1	1.0	6314C3	6314C3
	380	415	60	Δ/Y	86,25	160,6	147,1	92,7	0,88	3570	541				
F3 280 S-4	380	415	50	Δ/Y	75	141,1	129,2	95	0,85	1485	620	S1	1.0	6317C3	6317C3
	380	415	60	Δ/Y	86,25	165,8	151,8	93	0,85	1780	620				
F3 315 S-6	380	415	50	Δ/Y	75	145,1	132,9	94,6	0,83	990	860	S1	1.0	6319C3	6319C3
	380	415	60	Δ/Y	86,25	170,5	156,1	92,6	0,83	1185	860				
F3 280 M-2	380	415	50	Δ/Y	90	161,7	148,1	95	0,89	2975	645	S1	1.0	6314C3	6314C3
	380	415	60	Δ/Y	103,5	190,0	174,0	93	0,89	3570	645				
F3 280 M-4	380	415	50	Δ/Y	90	167,0	152,9	95,2	0,86	1490	673	S1	1.0	6317C3	6317C3
	380	415	60	Δ/Y	103,5	196,2	179,6	93,2	0,86	1785	673				
F3 315 M-6	380	415	50	Δ/Y	90	171,5	157,1	94,9	0,84	990	980	S1	1.0	6319C3	6319C3
	380	415	60	Δ/Y	103,5	201,5	184,5	92,9	0,84	1185	980				
F3 315 S-2	380	415	50	Δ/Y	110	192,9	176,6	95,2	0,91	2980	900	S1	1.0	6317C3	6317C3
	380	415	60	Δ/Y	126,5	226,6	207,5	93,2	0,91	3575	900				
F3 315 S-4	380	415	50	Δ/Y	110	201,4	184,4	95,4	0,87	1485	970	S1	1.0	6319C3	6319C3
	380	415	60	Δ/Y	126,5	236,5	216,6	93,4	0,87	1780	970				
F3 315 L-6	380	415	50	Δ/Y	110	209,2	191,6	95,1	0,84	990	1050	S1	1.0	6319C3	6319C3
	380	415	60	Δ/Y	126,5	245,8	225,0	93,1	0,84	1185	1050				
F3 315 M-2	380	415	50	Δ/Y	132	231,0	211,5	95,4	0,91	2980	1030	S1	1.0	6317C3	6317C3
	380	415	60	Δ/Y	151,8	271,4	248,5	93,4	0,91	3575	1030				
F3 315 M-4	380	415	50	Δ/Y	132	241,1	220,8	95,6	0,87	1485	1060	S1	1.0	6319C3	6319C3
	380	415	60	Δ/Y	151,8	283,2	259,3	93,6	0,87	1780	1060				
F3 315 LX-6	380	415	50	Δ/Y	132	247,3	226,5	95,4	0,85	985	1225	S1	1.0	6319C3	6319C3
	380	415	60	Δ/Y	151,8	290,5	266,0	93,4	0,85	1180	1225				
F3 315 L-2	380	415	50	Δ/Y	160	279,4	255,9	95,6	0,91	2980	1160	S1	1.0	6317C3	6317C3
	380	415	60	Δ/Y	184	328,2	300,5	93,6	0,91	3575	1160				
F3 315 L-4	380	415	50	Δ/Y	160	291,7	267,1	95,8	0,87	1485	1160	S1	1.0	6319C3	6319C3
	380	415	60	Δ/Y	184	342,6	313,7	93,8	0,87	1780	1160				
F3 355 M-6	380	415	50	Δ/Y	160	299,2	273,9	95,6	0,85	990	1790	S1	1.0	6322C3	6320C3
	380	415	60	Δ/Y	184	351,4	321,7	93,6	0,85	1190	1790				
F3 315 LX-2	380	415	50	Δ/Y	200	348,6	319,2	95,8	0,91	2980	1250	S1	1.0	6317C3	6317C3
	380	415	60	Δ/Y	230	409,4	374,9	93,8	0,91	3575	1250				
F3 315 LX-4	380	415	50	Δ/Y	200	359,7	329,4	96	0,88	1485	1270	S1	1.0	6319C3	6319C3
	380	415	60	Δ/Y	230	422,4	386,8	94	0,88	1780	1270				
F3 355 MY-6	380	415	50	Δ/Y	200	373,2	341,7	95,8	0,85	990	1890	S1	1.0	6322C3	6320C3
	380	415	60	Δ/Y	230	438,3	401,3	93,8	0,85	1190	1890				
F3 355 M-2	380	415	50	Δ/Y	250	435,7	399,0	95,8	0,91	2980	1780	S1	1.0	6317C3	6317C3
	380	415	60	Δ/Y	287,5	511,7	468,6	93,8	0,91	3580	1780				
F3 355 M-4	380	415	50	Δ/Y	250	444,6	407,1	96	0,89	1490	1815	S1	1.0	6322C3	6320C3
	380	415	60	Δ/Y	287,5	522,1	478,1	94	0,89	1785	1815				
F3 355 L-6	380	415	50	Δ/Y	250	461,0	422,2	95,8	0,86	990	1920	S1	1.0	6322C3	6320C3
	380	415	60	Δ/Y	287,5	541,5	495,8	93,8	0,86	1190	1920				
F3 355 L-2	380	415	50	Δ/Y	280	488,0	446,8	95,8	0,91	2985	1790	S1	1.0	6317C3	6317C3
	380	415	60	Δ/Y	322	573,1	524,8	93,8	0,91	3580	1790				
F3 355 L-4	380	415	50	Δ/Y	280	497,9	455,9	96	0,89	1490	1915	S1	1.0	6322C3	6320C3
	380	415	60	Δ/Y	322	584,8	535,5	94	0,89	1790	1915				
F3 355 LY-6	380	415	50	Δ/Y	280	516,4	472,8	95,8	0,86	990	2106	S1	1.0	6322C3	6320C3
	380	415	60	Δ/Y	322	606,5	555,3	93,8	0,86	1190	2106				
F3 355 LX-2	380	415	50	Δ/Y	315	549,0	502,7	95,8	0,91	2980	1808	S1	1.0	6317C3	6317C3
	380	415	60	Δ/Y	362,2	644,7	590,3	93,8	0,91	3580	1808				
F3 355 LX-4	380	415	50	Δ/Y	315	560,2	512,9	96	0,89	1490	2000	S1	1.0	6322C3	6320C3
	380	415	60	Δ/Y	362,2	657,8	602,3	94	0,89	1790	2000				
F3 355 L-2	380	415	50	Δ/Y	355	618,7	566,5	95,8	0,91	2980	1828	S1	1.0	6317C3	6317C3
	380	415	60	Δ/Y	408,2	726,6	665,3	93,8	0,91	3580	1828				

Aluminium Dimension

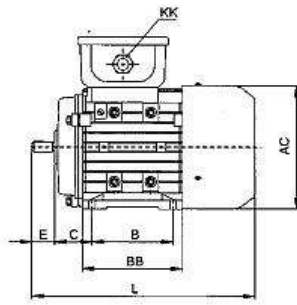

56-90

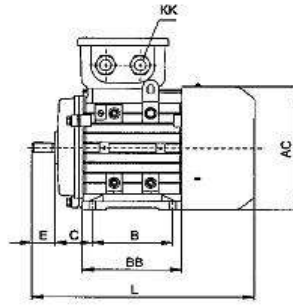

100-160

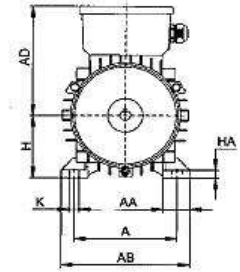

56-160

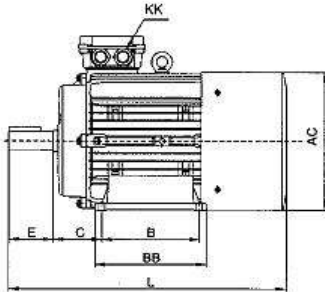

180-200

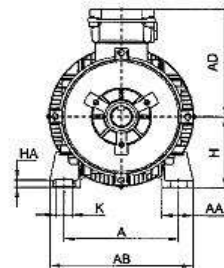

180-200

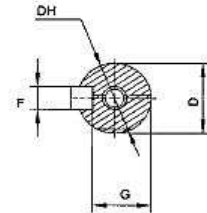

DIMENSIONI B3 DIMENSION B3

Type	A	AA	AB	BB	HA	AC	AD	B	C	D	DH	E	F	G	H	K	KK		Overall L
																	Metric	PG	
56	90	23	115	88	7	110	100	71	36	9	M4X12	20	3	7.2	56	5.8	1-M20X1.5	1-PG11	199
63	100	24	135	100	7	130	111	80	40	11	M4X12	23	4	8.5	63	7.0	1-M20X1.5	1-PG11	217
71	112	26	150	110	8	145	118	90	45	14	M5X12	30	5	11	71	7.0	1-M20X1.5	1-PG11	245
80	125	35	165	125	9	175	134	100	50	19	M6X16	40	6	15.5	80	10.0	1-M25X1.5	1-PG16	287
90S	140	37	180	125	10	195	140	100	56	24	M8X19	50	8	20.0	90	10.0	1-M25X1.5	1-PG16	315
90L	140	37	180	150	10	195	140	125	56	24	M8X19	50	8	20.0	90	10.0	1-M25X1.5	1-PG16	340
100L	160	40	205	172	11	215	160	140	63	28	M10X22	60	8	24.0	100	12.0	1-M32X1.5	1-PG21	385
112M	190	41	230	181	12	240	178	140	70	28	M10X22	60	8	24.0	112	12.0	2-M32X1.5	2-PG21	400
132S	216	51	270	186	15	275	206	140	89	38	M12X28	80	10	33.0	132	12.0	2-M32X1.5	2-PG21	483
132M	216	51	270	224	15	275	206	178	89	38	M12X28	80	10	33.0	132	12.0	2-M32X1.5	2-PG21	510
160M	254	55	320	260	18	330	255	210	108	42	M16X36	110	12	37.0	160	15.0	2-M40X1.5	2-PG29	615
160L	254	55	320	304	18	330	255	254	108	42	M16X36	110	12	37.0	160	16.0	2-M40X1.5	2-PG29	670
180M	279	75	350	315	18	355	272	241	221	48	M16X36	110	14	42.5	180	15	2-M32X1.5	2-PG29	765
180L	279	75	350	315	18	355	272	279	221	48	M16X36	110	14	42.5	180	15	2-M32X1.5	2-PG29	765
200L	318	100	398	355	24	355	272	305	133	55	M20X42	110	16	49	200	19	2-M32X1.5	2-PG36	790

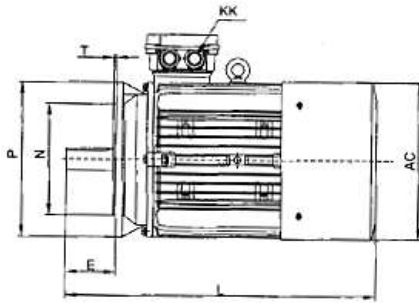

56-200

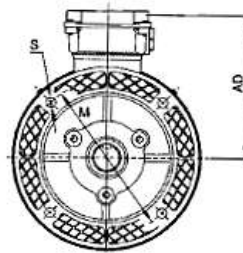

56-200

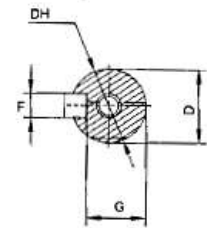

DIMENSIONI B5 DIMENSION B5

Type	HA	AC	AD	B	C	D	DH	E	F	G	H	K	KK		Overall dimensions					
													Metric	PG	L	M	N	P	S	T
56	7	110	100	71	36	9	M4X12	20	3	7.2	56	5.8	1-M20X1.5	1-PG11	199	100	80	120	7	3.0
63	7	130	111	80	40	11	M4X12	23	4	8.5	63	7.0	1-M20X1.5	1-PG11	217	115	95	140	10	3.0
71	8	145	118	90	45	14	M5X12	30	5	11	71	7.0	1-M20X1.5	1-PG11	245	130	110	160	12	3.5
80	9	175	134	100	50	19	M6X16	40	6	15.5	80	10.0	1-M25X1.5	1-PG16	287	165	130	200	12	3.5
90S	10	195	140	100	56	24	M8X19	50	8	20.0	90	10.0	1-M25X1.5	1-PG16	315	165	130	200	12	3.5
90L	10	195	140	125	56	24	M8X19	50	8	20.0	90	10.0	1-M25X1.5	1-PG16	340	165	130	200	12	3.5
100L	11	215	160	140	63	28	M10X22	60	8	24.0	100	12.0	1-M32X1.5	1-PG21	385	215	180	250	15	4.0
112M	12	240	178	140	70	28	M10X22	60	8	24.0	112	12.0	2-M32X1.5	2-PG21	400	215	180	250	15	4.0
132S	15	275	206	140	89	38	M12X28	80	10	33.0	132	12.0	2-M32X1.5	2-PG21	483	265	230	300	15	4.0
132M	15	275	206	178	89	38	M12X28	80	10	33.0	132	12.0	2-M32X1.5	2-PG21	510	265	230	300	15	4.0
160M	18	330	255	210	108	42	M16X36	110	12	37.0	160	15.0	2-M40X1.5	2-PG29	615	300	250	350	19	5.0
160L	18	330	255	254	108	42	M16X36	110	12	37.0	160	16.0	2-M40X1.5	2-PG29	670	300	250	350	19	5.0
180M	18	355	272	241	121	48	M16X36	110	14	42.5	180	15.0	2-M32X1.5	2-PG29	765	300	250	350	19	5
180L	18	355	272	279	121	48	M16X36	110	14	42.5	180	15.0	2-M32X1.5	2-PG29	765	300	250	350	19	5
200L	24	355	272	305	133	55	M20X42	110	16	49	200	19	2-M32X1.5	2-PG36	790	350	300	400	19	5

Aluminium Dimension

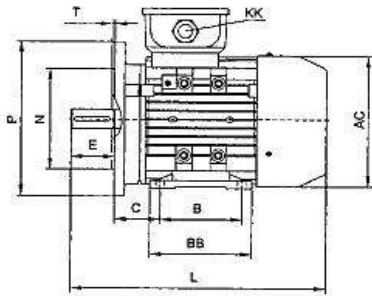

56-90

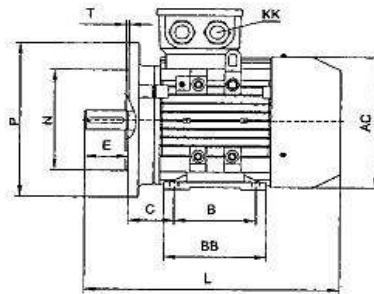

100-160

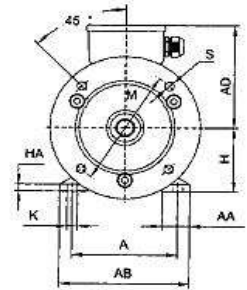

56-160

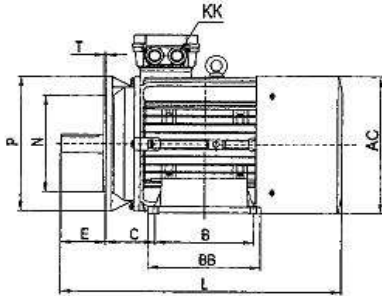

180-200

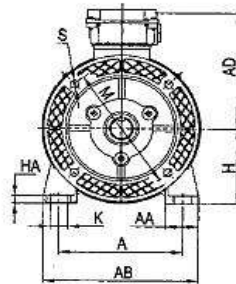

180-200

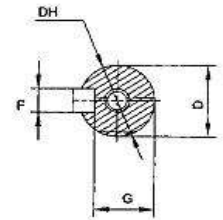

DIMENSIONI B35 DIMENSION B35

Type	A	AA	AB	BB	HA	AC	AD	B	C	D	DH	E	F	G	H	K	KK		Overall dimensions					
																	Metric	PG	L	M	N	P	S	T
56	90	23	115	88	7	110	100	71	36	9	M4X12	20	3	7.2	56	5.8	1-M20X1.5	1-PG11	199	100	80	120	7	3.0
63	100	24	235	100	7	130	111	80	40	11	M4X12	23	4	8.5	63	7.0	1-M20X1.5	1-PG11	217	115	95	140	10	3.0
71	112	26	150	110	8	145	118	90	45	14	M5X12	30	5	11	71	7.0	1-M20X1.5	1-PG11	245	130	110	160	12	3.5
80	125	35	165	125	9	175	134	100	50	19	M6X16	40	6	15.5	80	10.0	1-M25X1.5	1-PG16	287	165	130	200	12	3.5
90S	140	37	180	125	10	195	140	100	56	24	M8X19	50	8	20.0	90	10.0	1-M25X1.5	1-PG16	315	165	130	200	12	3.5
90L	147	37	180	150	10	195	140	125	56	24	M8X19	50	8	20.0	90	10.0	1-M25X1.5	1-PG16	340	165	130	200	12	3.5
100L	160	40	205	172	11	215	160	140	63	28	M10X22	60	8	24.0	100	12.0	1-M32X1.5	1-PG21	385	215	180	250	15	4.0
112M	190	41	230	181	12	240	178	140	70	28	M10X22	60	8	24.0	112	12.0	2-M32X1.5	2-PG21	400	215	180	250	15	4.0
132S	216	51	270	186	15	275	206	140	89	38	M12X28	80	10	33.0	132	12	2-M32X1.5	2-PG21	483	265	230	300	15	4.0
132M	216	51	270	224	15	275	206	178	89	38	M12X28	80	10	33.0	132	12.0	2-M32X1.5	2-PG21	510	265	230	300	15	4.0
160M	254	55	320	260	18	330	255	210	108	42	M16X36	110	12	37.0	160	15.0	2-M40X1.5	2-PG29	615	300	250	350	19	5.0
160L	254	55	320	304	18	330	255	254	108	42	M16X36	110	12	37.0	160	16.0	2-M40X1.5	2-PG29	670	300	250	350	19	5.0
180M	279	75	350	315	18	355	272	241	121	48	M16*36	110	14	42.5	180	15	2-M32X1.5	2-PG29	765	300	250	350	19	5
180L	279	75	350	315	18	355	272	279	121	48	M16*36	110	14	42.5	180	15	2-M32X1.5	2-PG29	765	300	250	350	19	5
200L	318	100	398	355	24	355	272	305	133	55	M20*42	110	16	49	200	19	2-M32X1.5	2-PG36	790	350	300	400	19	5

Cast Iron Dimension

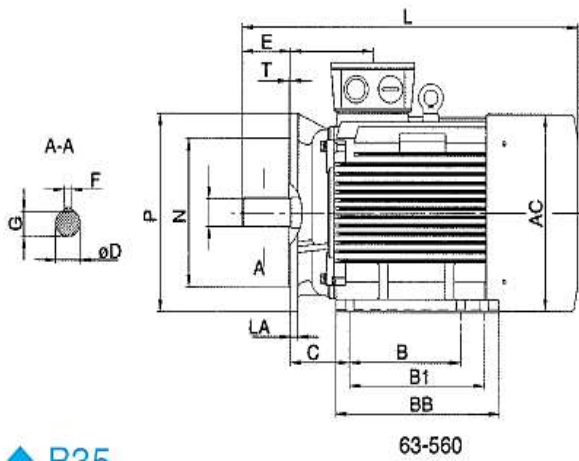

63-560

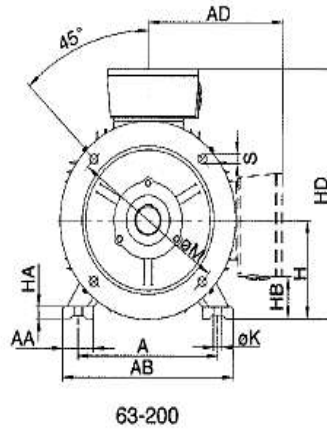

63-200

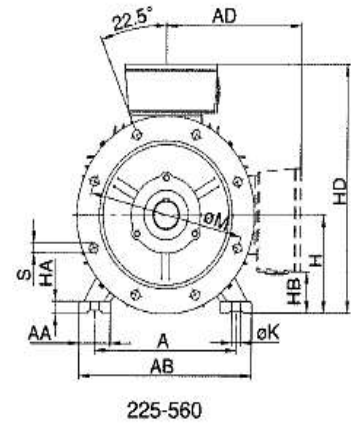

225-560

◆ B35

Frame	Poles	Dimension														Dimension											
		A	B	B1	C	CA	H	K	M	N	P	R	S	T	AA	AB	AC	AD	BB	HA	HB	HD		LA	LD	L	LC
																						Top	L&R				
80	2-8	125	100	-	50	98	80° _{-0,5}	10	165	130	200	0	4-012	4	35	160	160	145	130	12	36	225	160	12	75	280	336
90S	2-8	140	100	-	56	117	90° _{-0,5}	10	165	130	200	0	4-012	4	36	180	180	155	140	12	50	245	180	12	75	315	373
90L	2-8	140	125	-	56	117	90° _{-0,5}	10	165	130	200	0	4-012	4	36	180	180	155	165	12	50	245	180	12	75	340	373
100L	2-8	160	140	-	63	120	100° _{-0,5}	12	215	180	250	0	4-015	4	40	200	200	180	175	14	55	280	200	13	83	375	443
112M	2-8	190	140	-	70	138	112° _{-0,5}	12	215	180	250	0	4-015	4	45	230	220	190	180	15	60	305	222	14	87	400	468
132S	2-8	216	140	-	89	164	132° _{-0,5}	12	265	230	300	0	4-015	4	55	265	260	220	190	18	65	355	262	14	102	465	553
132M	2-8	216	178	-	89	146	132° _{-0,5}	12	265	230	300	0	4-015	4	55	265	260	220	230	18	65	355	262	14	102	505	593
160M	2-8	254	210	-	108	188	160° _{-0,5}	15	300	250	350	0	4-019	5	65	315	315	265	260	20	81	425	385	15	146	608	726
160L	2-8	254	254	-	108	188	160° _{-0,5}	15	300	250	350	0	4-019	5	65	315	315	265	305	20	81	425	385	15	146	652	770
180M	2.4	279	241	-	121	226	180° _{-0,5}	15	300	250	350	0	4-019	5	70	350	360	280	315	22	105	460	420	15	161	690	808
180L	4-8	279	279	-	121	228	180° _{-0,5}	15	300	250	350	0	4-019	5	70	350	360	280	350	22	105	460	420	15	161	730	848
200L	2-8	318	305	-	133	220	200° _{-0,5}	19	350	300	400	0	4-019	5	70	390	400	310	370	25	85	510	475	17	186	760	878
225S	4-8	356	286	-	149	243	225° _{-0,5}	19	400	350	450	0	4-019	5	75	435	450	335	370	28	110	555	535	20	189	810	928
225M	2	356	311	-	149	243	225° _{-0,5}	19	400	350	450	0	4-019	5	75	435	450	335	395	28	110	555	535	20	189	805	923
	4-8	356	311	-	149	198	225° _{-0,5}	19	400	350	450	0	4-019	5	75	435	450	335	395	28	110	555	535	20	189	835	953
250M	2	406	349	-	168	261	250° _{-0,5}	24	500	450	550	0	4-019	5	80	485	485	375	445	30	110	625	570	22	207	910	1028
	4-8	406	349	-	168	261	250° _{-0,5}	24	500	450	550	0	4-019	5	80	485	485	375	445	30	120	625	570	22	207	910	1028
280S	2	457	368	-	190	295	280° _{+1,0}	24	500	450	550	0	4-019	5	85	545	550	405	490	35	142	685	660	22	215	985	1103
	4-8	457	368	-	190	315	280° _{+1,0}	24	500	450	550	0	4-019	5	85	545	550	405	490	35	142	685	660	22	215	1005	1153
280M	2	457	419	-	190	289	280° _{+1,0}	24	500	450	550	0	4-019	5	85	545	550	405	540	35	142	685	660	22	215	1030	1148
	4-8	457	419	-	190	319	280° _{+1,0}	24	500	450	550	0	4-019	5	85	545	550	405	540	35	142	685	660	22	215	1060	1208
315S	2	508	406	-	216	426	315° _{+1,0}	28	600	550	660	0	4-024	6	120	630	625	560	570	45	110	875	780	22	257	1180	1328
	4-8	508	406	-	216	426	315° _{+1,0}	28	600	550	660	0	4-024	6	120	630	625	560	570	45	110	875	780	22	257	1210	1358
315M	2	508	457	508	216	485	315° _{+1,0}	28	600	550	660	0	4-024	6	120	630	625	560	680	45	110	875	780	22	257	1290	1438
	4-8	508	457	508	216	485	315° _{+1,0}	28	600	550	660	0	4-024	6	120	630	625	560	680	45	110	875	780	22	257	1320	1498
355M	2	610	500	560	254	640	355° _{+1,0}	28	740	680	800	0	4-024	6	120	730	700	615	750	52	125	970	830	25	284	1526	1674
	4-8	610	500	560	254	640	355° _{+1,0}	28	740	680	800	0	4-024	6	120	730	700	615	750	52	125	970	830	25	284	1556	1734
355L	2	610	560	630	254	580	355° _{+1,0}	28	740	680	800	0	4-024	6	120	730	700	615	750	52	125	970	830	25	284	1526	1674
	4-8	610	560	630	254	580	355° _{+1,0}	28	740	680	800	0	4-024	6	120	730	700	615	750	52	125	970	830	25	284	1556	1734
400M	2	686	710	-	280	698	400° _{+1,0}	35	940	880	1000	0	4-028	6	120	810	860	-	1100	45	-	1090	-	25	362	1850	2028
	4-8	686	710	-	280	733	400° _{+1,0}	35	940	880	1000	0	4-028	6	120	810	860	-	1100	45	-	1090	-	25	362	1925	2143

Cast Iron Dimension

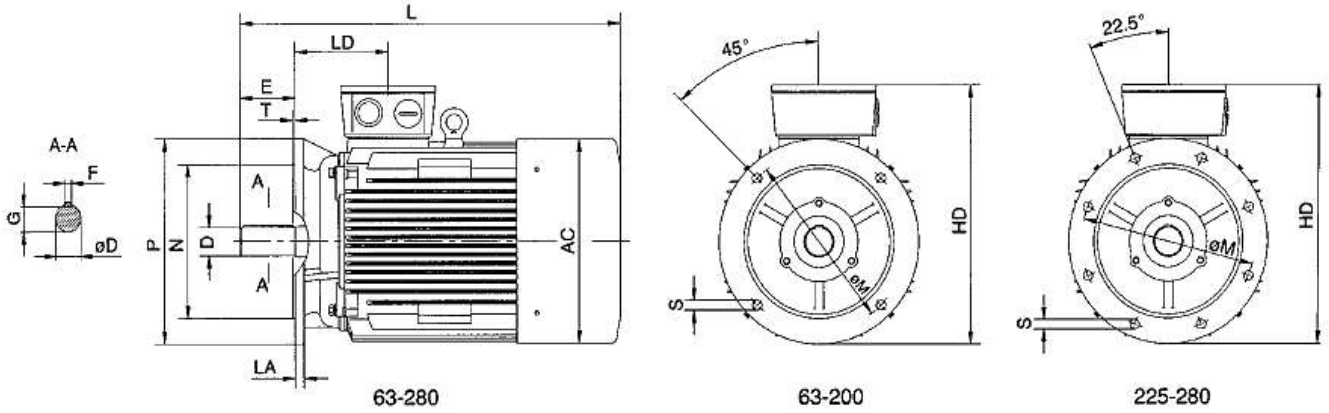

◆ B5

Frame	Pole	Dimension						Dimension					
		M	N	P	R	S	T	AC	AD	LA	LD	L	LC
80	2-8	165	130	200	0	4-ø12	4	160	145	12	75	280	336
90S	2-8	165	130	200	0	4-ø12	4	180	155	12	75	315	373
90L	2-8	165	130	200	0	4-ø12	4	180	155	12	75	340	373
100L	2-8	215	180	250	0	4-ø15	4	200	180	13	83	375	443
112M	2-8	215	180	250	0	4-ø15	4	220	193	14	87	400	468
132S	2-8	265	230	300	0	4-ø15	4	260	223	14	102	465	553
132M	2-8	265	230	300	0	4-ø15	4	260	223	14	102	505	593
160M	2-8	300	250	350	0	4-ø19	5	315	265	15	146	608	726
160L	2-8	300	250	350	0	4-ø19	5	315	265	15	146	652	770
180M	2.4	300	250	350	0	4-ø19	5	360	280	15	161	690	808
180L	4-8	300	250	350	0	4-ø19	5	360	280	15	161	730	848
200L	2-8	350	300	400	0	4-ø19	5	400	310	17	186	760	878
225S	4-8	400	350	450	0	4-ø19	5	450	330	20	189	810	928
225M	2	400	350	450	0	4-ø19	5	450	330	20	189	805	923
	4-8	400	350	450	0	4-ø19	5	450	330	20	189	835	953
250M	2	500	450	550	0	4-ø19	5	485	375	22	207	910	1028
	4-8	500	450	550	0	4-ø19	5	485	375	22	207	910	1028
280S	2	500	450	550	0	4-ø19	5	550	405	22	215	985	1103
	4-8	500	450	550	0	4-ø19	5	550	405	22	215	1005	1153
280M	2	500	450	550	0	4-ø19	5	550	405	22	215	1030	1148
	4-8	500	450	550	0	4-ø19	5	550	405	22	215	1060	1208

Cast Iron Dimension

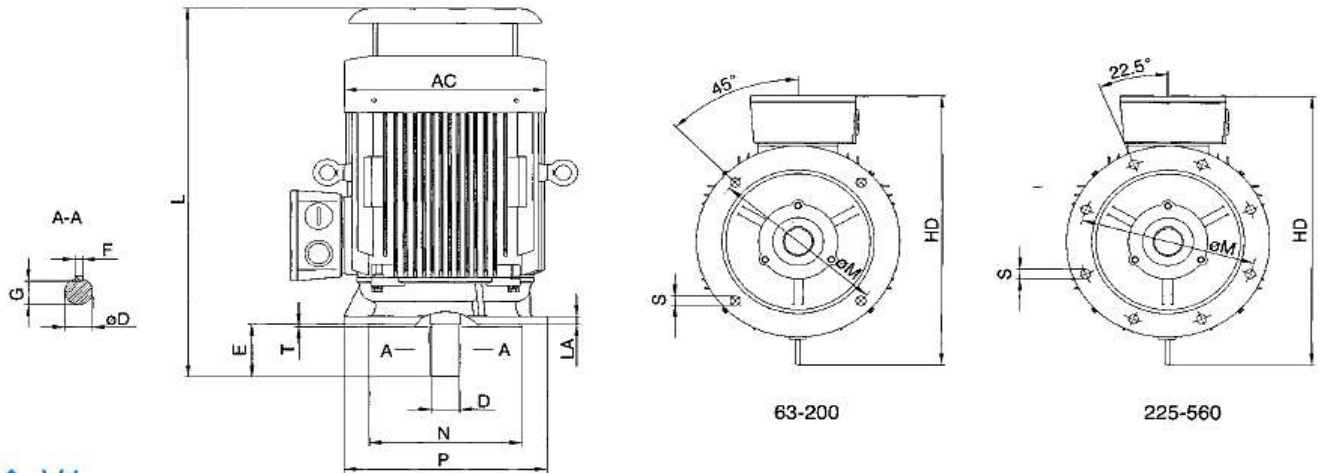

◆ V1

Frame	Pole	Dimension										Dimension				
		D	E	F	G	M	N	P	R	S	T	AC	HD	LA	LD	L
80	2-8	19	40	6	15.5	165	130	200	0	4- ϕ 12	4	160	225	12	75	305
90S	2-8	24	50	8	20	165	130	200	0	4- ϕ 12	4	180	245	12	75	345
90L	2-8	24	50	8	20	165	130	200	0	4- ϕ 12	4	180	245	12	75	370
100L	2-8	28	60	8	24	215	180	250	0	4- ϕ 15	4	200	280	13	83	410
112M	2-8	28	60	8	24	215	180	250	0	4- ϕ 15	4	220	305	14	87	450
132S	2-8	38	80	10	33	265	230	300	0	4- ϕ 15	4	260	365	14	102	510
132M	2-8	38	80	10	33	265	230	300	0	4- ϕ 15	4	260	365	14	102	550
160M	2-8	42	110	12	37	300	250	350	0	4- ϕ 19	5	315	445	15	146	660
160L	2-8	42	110	12	37	300	250	350	0	4- ϕ 19	5	315	445	15	146	705
180M	2.4	48	110	14	42.5	300	250	350	0	4- ϕ 19	5	360	480	15	161	750
180L	4-8	48	110	14	42.5	300	250	350	0	4- ϕ 19	5	360	480	15	161	790
200L	2-8	55	110	16	49	350	300	400	0	4- ϕ 19	5	400	530	17	186	840
225S	4-8	60	140	18	53	400	350	450	0	4- ϕ 19	5	450	575	20	189	905
225M	2	55	110	16	49	400	350	450	0	4- ϕ 19	5	450	575	20	189	910
	4-8	60	140	18	53	400	350	450	0	4- ϕ 19	5	450	575	20	189	935
250M	2	60	140	18	53	500	450	550	0	4- ϕ 19	5	485	635	22	207	1005
	4-8	65	140	18	58	500	450	550	0	4- ϕ 19	5	485	635	22	207	1005
280S	2	65	140	18	58	500	450	550	0	4- ϕ 19	5	550	725	22	215	1110
	4-8	75	140	20	67.5	500	450	550	0	4- ϕ 19	5	550	725	22	215	1130
280M	2	65	140	18	58	500	450	550	0	4- ϕ 19	5	550	725	22	215	1155
	4-8	75	140	20	67.5	500	450	550	0	4- ϕ 19	5	550	725	22	215	1185
315S	2	65	140	18	58	600	550	660	0	4- ϕ 24	6	625	895	22	257	1340
	4-8	80	170	22	71	600	550	660	0	4- ϕ 24	6	625	895	22	257	1370
315M	2	65	140	18	58	600	550	660	0	4- ϕ 24	6	625	895	22	257	1450
315L	4-8	80	170	22	71	600	550	660	0	4- ϕ 24	6	625	895	22	257	1480
355M	2	75	140	20	67.5	740	680	800	0	4- ϕ 24	6	700	970	25	284	1665
355L	4-8	100	210	25	86	740	680	800	0	4- ϕ 24	6	700	970	25	284	1700
400M	2	80	170	22	71	940	880	1000	0	4- ϕ 28	6	860	1150	25	362	2150
400L	4-8	110	210	28	100	940	880	1000	0	4- ϕ 28	6	860	1150	25	362	2220

**DIMENSIONE ALBERO
SERIE GHISA**

**DIMENSION SHAF
CAST IRON SERIES**

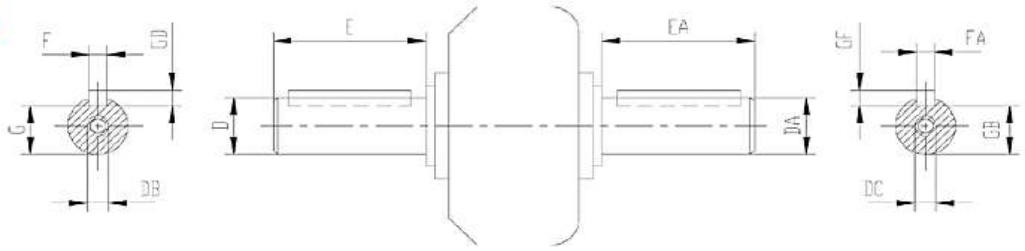

Frame	Pole	D	DA	E	EA	F	FA	G	GB	GD	GF	DB	DC
56	2-4	9 j6(+0.007/-0.002)	9 j6(+0.007/-0.002)	20	20	3	3	7	7	3	3	M3	M3
63	2-4	11 j6(+0.008/-0.003)	11 j6(+0.008/-0.003)	23	23	4	4	8.5	8.5	4	4	M4	M4
71	2-4-6	14 j6(+0.008/-0.003)	14 j6(+0.008/-0.003)	30	30	5	5	11	11	5	5	M5	M5
80	2-4-6-8	19 j6(+0.009/-0.004)	19 j6(+0.009/-0.004)	40	40	6	6	15.5	15.5	6	6	M6	M6
90S	2-4-6-8	24 j6(+0.009/-0.004)	24 j6(+0.009/-0.004)	50	50	8	8	20	20	7	7	M8	M8
90L	2-4-6-8												
100L	2-4-6-8	28 k6(+0.009/-0.004)	28 k6(+0.009/-0.004)	60	60	8	8	24	24	7	7	M10	M10
112M	2-4-6-8												
132S	2-4-6-8	38 k6(+0.018/-0.002)	38 k6(+0.018/-0.002)	80	80	10	10	33	33	8	8	M12	M12
132M	2-4-6-8												
160M	2-4-6-8	42 k6(+0.018/-0.002)	42 k6(+0.018/-0.002)	110	110	12	12	37	37	9	9	M16	M16
160L	2-4-6-8												
180M	2-4	48 k6(+0.018/-0.002)	48 k6(+0.018/-0.002)	110	110	14	14	42.5	42.5	9	9	M16	M16
180L	4-6-8												
200L	2	55 m6(+0.03/-0.011)	48 k6(+0.018/-0.002)	140	140	16	14	49	42.5	10	9	M20	M20
	4-6-8												
225S	4-6-8	60 m6(+0.03/-0.011)	55 m6(+0.03/-0.011)	140	140	18	16	53	49	11	10	M20	M20
	2												
225M	2	60 m6(+0.03/-0.011)	48 k6(+0.018/-0.002)	110	110	16	14	49	42.5	10	9	M20	M20
	4-6-8												
250M	2	65 m6(+0.03/-0.011)	60 m6(+0.03/-0.011)	140	140	18	16	53	49	11	10	M20	M20
	4-6-8												
280S	2	75 m6(+0.03/-0.011)	65 m6(+0.03/-0.011)	140	140	18	16	58	49	11	10	M20	M20
	4-6-8												
280M	2	75 m6(+0.03/-0.011)	55 m6(+0.03/-0.011)	140	140	20	18	67.5	53	12	11	M20	M20
	4-6-8												
315S	2	80 m6(+0.03/-0.011)	65 m6(+0.03/-0.011)	170	170	22	22	71	71	14	14	M24	M24
	4-6-8												
315M	2	80 m6(+0.03/-0.011)	65 m6(+0.03/-0.011)	170	170	22	22	71	71	14	14	M24	M24
	4-6-8												
355M	2	100 m6(+0.035/-0.013)	75 m6(+0.03/-0.011)	210	170	28	25	86	86	14	14	M24	M24
	4-6-8												
355L	2	100 m6(+0.035/-0.013)	75 m6(+0.03/-0.011)	210	170	28	25	86	86	14	14	M24	M24
	4-6-8												
400M	2	110 m6(+0.035/-0.013)	80 m6(+0.03/-0.011)	210	210	28	28	100	100	16	16	M24	M24
	4-6-8												

**CARICHI ASSIALI AMMESSI.
PERMISSIBLE AXIAL LOADS.**

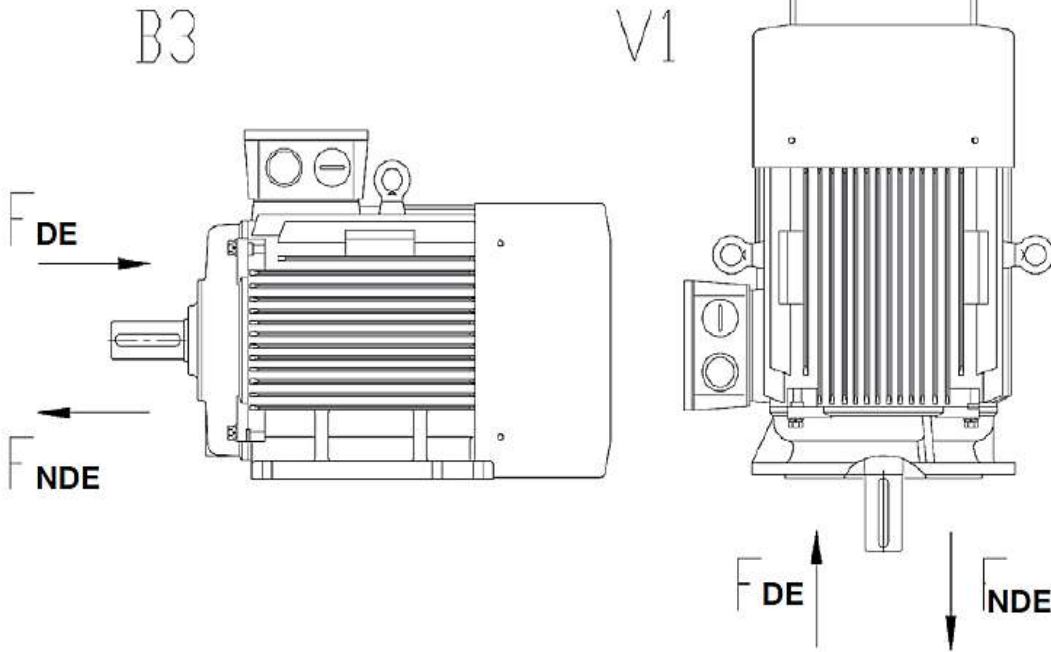

La seguente tabella fornisce le forze assiali ammissibili in Newton, assumendo come zero forza radiale. In questo caso il motore deve essere ordinato con cuscinetti a sfere standard. In caso di forze assiali superiori ai valori riportati nella tabella devono essere ordinati motori con cuscinetto a contatto angolare. I valori si basano su condizioni normali a 50Hz. e calcolato a 20000 ore di lavoro per motori a 2 poli e 40000 ore per i motori 4, 6 e 8 poli.

A 60Hz. i valori devono essere ridotti del 10%. Per i motori a due velocità i valori devono essere basati presso la velocità più elevata.

F_{pressure} (D.E.) è calcolata per un cuscinetto fisso sul lato comando.

The following table gives the permissible axial forces in Newton, assuming zero radial force. In this case motor should be ordered with standard ball bearings. In case of higher axial force than given in the table an angular contact bearing should be ordered. The values are based on normal conditions at 50Hz. and calculated at 20000 working hour for two pole motors and 40000 hours for 4, 6 and 8 pole motors. At 60Hz. the values must be reduced by 10%. For two-speed motors the values have to be based at the higher speed.

F_{pressure} (D.E.) is calculated for a fixed bearing at the Drive End.

Frame Size	pole	Maximum axial force (FA)			
		B3 FDE	B3 FNDE	V1 FDE	V1 FNDE
56	2	200	200	230	180
	4	240	240	260	200
63	2	250	250	260	230
	4	280	280	300	260
71	2	270	270	290	255
	4	350	350	370	320
	6	440	440	460	420
80	2	380	380	400	360
	4	470	470	490	450
	6	590	590	620	560
	8	620	620	650	595
90	2	440	440	470	410
	4	550	550	600	510
	6	620	620	680	460
	8	640	640	700	580
100	2	610	610	670	570
	4	750	750	840	710
	6	880	880	970	820
	8	895	895	970	845
112	2	1220	1220	1300	1170
	4	1440	1440	1520	1370
	6	1650	1650	1740	1580
	8	1780	1780	1880	1710
132	2	1500	1500	1620	1430
	4	1780	1780	1970	1610
	6	1820	1820	2000	1660
	8	1920	1920	2100	1760
160	2	1650	1650	1950	1350
	4	2100	2100	2470	1720
	6	2450	2450	2800	2050
	8	2650	2650	3050	2210

Frame Size	pole	Maximum axial force (FA)			
		B3 FDE	B3 FNDE	V1 FDE	V1 FNDE
180	2	2100	2100	2450	1720
	4	2600	2600	3200	2000
	6	2900	2900	3510	2280
200	8	3170	3170	3780	2550
	2	2400	2400	2940	1840
	4	3120	3120	3850	2390
	6	3480	3480	4350	2610
225	8	3950	3950	4810	3090
	2	2720	2720	3420	2020
	4	3480	3480	4370	2590
	6	3890	3890	5040	2820
250	8	4330	4330	5330	3330
	2	3100	3100	3940	2260
	4	3900	3900	5000	2800
	6	4450	4450	5570	3230
280	8	4980	4980	6380	3580
	2	5300	3100	6500	2100
	4	6300	4400	7800	3000
	6	6700	4300	7900	2900
315	8	7100	5020	9100	3520
	2	5900	3800	8000	2000
	4	7100	5100	10700	3150
	6	7600	5800	11800	3500
355*	8	8100	6300	12500	4400
	2	6100	1850	14000	800
	4	9800	3900	18300	2500*
	6	10500	4700	20700	3500*
400*	8	12500	6000	21500	3600*
	4	11200	3900	18500	1600*
	6	12500	4800	19500	2200*
	8	12800	4950	21500	2900*

*= Dati calcolati con cuscinetti a rulli

*= Data calculated with roll bearings

Per forme costruttive diverse e/o carichi diversi contattare FELM

Consult FELM for other mounting or different loads

CARICHI RADIALI AMMESSI. PERMISSIBLE RADIAL LOADS.

La seguente tabella fornisce le forze assiali ammissibili in Newton, assumendo come zero forza radiale. In questo caso il motore deve essere ordinato con cuscinetti a sfere standard. In caso di forze assiali superiori ai valori riportati nella tabella devono essere ordinati motori con cuscinetto a contatto angolare. I valori si basano su condizioni normali a 50Hz. e calcolato a 20000 ore di lavoro per motori a 2 poli e 40000 ore per i motori 4, 6 e 8 poli. A 60Hz. i valori devono essere ridotti del 10%. Per i motori a due velocità i valori devono essere basati presso la velocità più elevata. Fpressure (D.E.) è calcolata per un cuscinetto fisso sul lato comando.

The following table give the permissible radial forces in Newton, assuming zero axial force and standard ball bearings. In case of higher radial force than give in the table an enforced bearing should be ordered. The values are based on normal conditions at 50 Hz and calculated at 20 000 working hours for the two pole motors and 40 000 working hours for 4,6 and 8 poles. For 60 Hz the value must be reduced by 10%. For two speed motors, the values have to be based at the higher speed.

Diametro puleggio: Pulley diameter:

Quando la durata del cuscinetto desiderato è stato determinato, il diametro della puleggia minimo può essere calcolato con la seguente formula:
When the desired bearing life has been determined, the minimum pulley diameter can be calculated with the following formula:

$$D_{min} = \frac{1.9 \times 10^7 \times k \times p_N}{n_N \times F_R}$$

D_{min} = diameter of the pulley (mm)

P = power of the motor (kW)

n = motor rated speed(r/min)

K = belt tension factor , $k=2.5$ for V-belt

$FR(X)$ = permissible radial force (N)

$$FR = F_R = F_{X0} - \frac{X}{E} (F_{X0} - F_{XMAX})$$

E = the length of the shaft diameter (mm.) in basic version

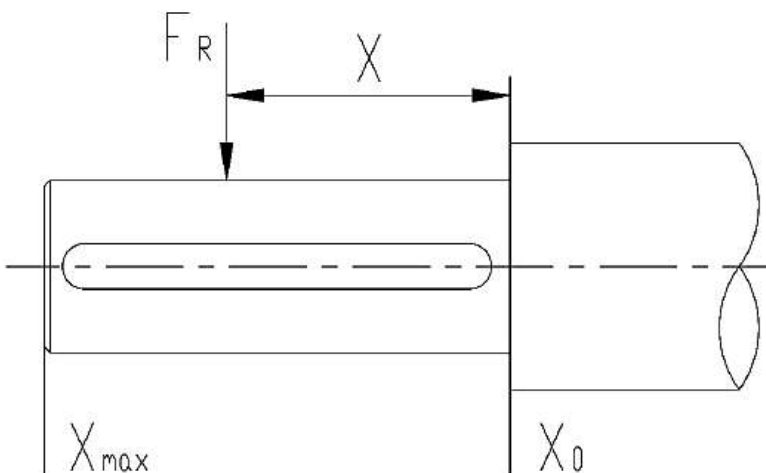

Size	pole	Maximum radial force (F_R)		
		X0	X1/2	Xmax
56	2	250	180	100
	4	250	180	100
63	2	360	300	230
	4	360	300	230
71	2	470	400	320
	4	470	400	320
	6	470	400	320
80	2	670	610	550
	4	730	650	590
	6	830	750	680
	8	920	820	750
90	2	740	660	590
	4	800	710	630
	6	920	810	730
	8	1010	890	800
100	2	1030	920	820
	4	1110	990	890
	6	1270	1130	1020
	8	1400	1240	1120
112	2	1490	1330	1200
	4	1600	1430	1290
	6	1840	1640	1480
	8	2020	1800	1630
132	2	2160	1900	1690
	4	2330	2040	1820
	6	2670	2340	2080
	8	2940	2570	2290
160	2	2800	2440	2170
	4	3000	2630	2330
	6	3440	3010	2670
	8	3850	3410	3060

Frame Size	pole	Maximum radial force (F_R)		
		X0	X1/2	Xmax
180	2	3930	3500	3150
	4	4240	3770	3390
	6	4890	4390	3980
	8	5380	4830	4380
200	2	4480	4050	3700
	4	4820	4360	3980
	6	5520	5000	4560
	8	6080	5500	5020
225	2	5000	4540	4160
	4	5360	4720	4210
	6	6180	5480	4920
	8	6750	5940	5310
250	2	5680	5100	4620
	4	6120	5490	4980
	6	7000	6280	5700
	8	7710	6920	6270
280	2	5620	5080	4640
	4	7790	7050	6430
	6	8920	8060	7360
	8	9820	8880	8100
315	2	7370	6840	6390
	4	9150	8370	7720
	6	10480	9590	8830
	8	11530	10550	9720
355*	2	16330	15390	8730
	4	28300	25860	14290
	6	32400	29600	16350
	8	35660	32580	18000
400*	4	33730	31140	19280
	6	38610	35650	22070
	8	42500	39240	24290

CONTACTS

Head Quarter

FELM srl

Via Morandi (Industrial Area)

20010 Inveruno (Mi) Italy

Tel. +39 02 97 289 454

Tel. +39 02 97 288 320

Fax +39 02 97 289 923

E-mail home@felm.it

FELM Office Middle East

Al Saalam Street, Al Darwish Building (NBAD building)
office no. 1403 Abu Dhabi (United Arab Emirates) P.O. Box
45223

Office Ph. + 971-2-6710330

Office Fax + 971-2-6710255

mobile +971 50 4442093

Email: ayman.abdallah@felm.it

FELM Office Germany

Heinrich-Busold-Strasse 47

D-61169 Friedberg (Hessen), Germany

Tel (Off): +49-6031-721606

Mobile: +49-172-6729011

Fax: +49-6031-721610

Email: Jayant@jk-conrep.de

FELM Office China

Add: Room 1002, Building 3#,

No 139 Rd.SongShan,

Jianye, Nanjing, Jiangsu, China

Fax:+86-25-87797622

Tel:+86-15077829999

Email: lidongming1974@vip.sina.com

FELM Office UK

The Foundry, Wadebridge

Cornwall, PL277PG

United Kingdom

Tel (Off): +441208 816543

Mobile: +447791717488

Email: Toby@felm.co.uk

WORLD WIDE SERVICE

Mobile +39 355 69 53 804

E-mail service@felm.it





Electric Motors - www.felm.it

MARINE MOTORS





MARINE MOTORS

FELM®

Felm® and Its Partners are one of the leading trading and manufacturer of electric motors for the global industrial market, with motor solutions, which benefit a wide range of customers.

Our products are used in almost every industrial activity including water treatment, building services, chemical/petrochemicals, general processing and manufacturing where they drive fans, pumps, compressors and conveyors, amongst other things.

We have extensive stocks of motors in our facilities from 0,12 kW to 500 kW.

Thanks to our worldwide network We are ensuring excellent local support wherever needed.

Quality assurance

Stringent quality procedures are observed from first design to finished product in accordance with the ISO9001 documented Quality Systems. All of our factories have been assessed to meet these requirements, a further assurance that only the highest possible standards of quality are accepted.

Marine motors

Felm and Its Partners are one of the worldwide leading manufacturers of Low Voltage A.C. Electric Motors for the marine and other industries. Features developed over many years for the arduous conditions of the Sea have now been incorporated into standard motors.

These include, for example, high performance paint treatments, stainless steel nameplates, higher standards of balancing and built-in electrical protection - all particularly important to the marine industry.

The standard totally enclosed motors, which meet the latest requirements for high efficiency and low noise levels, are house-proof and can be readily produced in deck watertight enclosures.

Like last proposal to the market New Motors range is offered to the market with Motors in according to the New efficiency rule IE3. More data are offered in the next pages.

Where weight is an important consideration, open drip-proof motors are available.

Certified hazardous area motors are a speciality of the company which is also experienced in obtaining approval from most of the world's marine certifying authorities.

Benefits include:

- high power
- low power consumption
- low noise levels
- voltage: 690 V
- IE3 efficiency value in according to the rules and the tolerances the New Standard IEC 60034-30
- frequency: 60 Hz
- high torque with smooth acceleration and low current
- IP55 or on request IP56-65-66 protection

Standards and regulations

The motors conform to the relevant standards and regulations:

Table 1

Title	DIN/EN	IEC
Rotating electrical machines Rating and performance	DIN EN 60034-1	IEC 60034-1 IEC 60085
Determination of losses and efficiency	DIN EN 60034-2	IEC 60034-2
IP degrees of protection	DIN EN 60034-5	IEC 60034-5
Methods of cooling (IC code)	DIN EN 60034-6	IEC 60034-6
Types of construction (IM code)	DIN EN 60034-7	IEC 60034-7
Terminal markings and direction of rotation	DIN VDE 0530-8	IEC 60034-8
Noise limits	DIN EN 60034-9	IEC 60034-9
Built-in thermal protection; rules for protection		IEC 60034-11
Starting performance of single-speed three-phase cage induction motors, excluding pole-changing motors, for voltages up to and including 690V/50Hz	DIN EN 60034-12	IEC 60034-12
Mechanical vibration of certain machines with shaft heights of 56 mm and above	DIN EN 60034-14	IEC 60034-14
Standard voltages	DIN EN 60038	IEC 60038
VFD installed appropriate motor construction		IEC 60034-25
Rotating electrical machines new efficiency class – IE code	DIN EN 60034-30	IEC 60034-30
Three-phase motors for general use with standardized dimensions and outputs	DIN EN 50347	IEC 60072 1
Centre bores 60° with thread, DR form	DIN 332-2	
Drive-type fastenings without taper action: feather keys; keyways; deep pattern	DIN 6885-1	
Standard and Regulation: Electrical installations in ship		IEC 60092
Frame surface cooled three-phase squirrel-cage motors, IM B3 type of construction, with rolling-contact bearings; output classification for explosion-protected design in increased safety protection “e”	DIN 42673-2	

1) IEC 60072 only provides for dimensions, but does not define any output classifications.

Environment Enclosure

All motors have degrees of IP 55 protection as defined in IEC EN 60034-5.

Motors installed on weather decks and those used for grinders, pulpers and axial flow fans shall be completely enclosed (IP 56 protection).

The Motors and cubicles for window washing system shall be IP66 rate.

Motor cooling

Motors are cooled in accordance with EN 60034-6. The normal arrangement is IC411 TEFV .

IE3 - type FM3, FM3VP**New International Standard Efficiency Level IE3 IEC 60034-30**

Prepared by IEC technical committee 2: Rotating machinery

The new international standard, IEC 60034-30:2008, defines efficiency classes IE1, IE2 and IE3 for three-phase motors. This ensures a common international basis for the design and classification of motors as well as for national legislative activities. At the same time, the IEC developed improved methods for determining the efficiency of these motors.

The international standards IEC 60034-30:2008 (classification) and IEC 60034-2-1:2007 (measuring methods) have been adopted as European standards without any changes as EN 60034-30:2009 and

EN 60034-2-1:2007. For the sake of simplicity, the following sections will refer to the IEC standards only.

FELM grant the IE3 Efficiency value for max + 50°C ambient temperature.

FELM IE3 Efficiency Motors type:

FM3, FM3VP Cast Iron Frames



European directives

European directives apply in varying degrees to A.C. induction motors.

Felm comply in the following manner

Table 8

Compliance with European directives applying to AC induction motors				
Directives	Low voltage (LV)	Machinery (MD)	Electromagnetic compatibility (EMC)	ATEX
Reference numbers	73/23/EEC 93/68/EEC	89/392/EEC 91/368/EEC 93/44/EEC 93/68/EEC	89/336/EEC 92/31/EEC 93/68/EEC	94/9/EC
Motor CE marked Standards	Yes EN 60034	No Not applicable	No EN 60034-1	YES EN60079-0 EN60079-1 EN60079-7
Documentation for customers' technical file	Declaration of conformity	Certificate of incorporation	Statement (1)	Declaration of conformity
Safety instructions with every motor	Yes	Yes	Yes	Yes
Comment	Relevant electrical equipment operating between 50 to 1000 volts AC	Statement (2)	Component	Hazardous atmosphere equipment - mandatory after July 2003

(1) Motors operating from a correctly applied, sinusoidal (AC) supply meet the requirements of the EMC directive and are within the limits specified in standard EN 60034-1

(2) When installed in accordance with our customer safety and installation and maintenance instructions, they can be put into service only when the machinery into which they are being incorporated, has been declared to be in conformity with the machinery directive in accordance with Article 4(2) and Annex IIB of that Directive. (98/37/EEC) 94/9/EC



Marine duty motors general details

The motors described in this catalogue are designed and rated for use on board merchant and passenger ships built anywhere in the world and in accordance with the requirements of the major marine classification authorities. These requirements generally concern limits to winding temperature rise with given ambient temperatures, which determine the motor frame size for a given output. For certain larger motors, some authorities specify normalised shaft steel to give greater consistency. The requirements for witnessed tests, type tests, certification etc, differ between authorities and can all be accommodated. However, these exceptional demands must be made clear at the time of ordering. The table opposite gives a list of the major classifying authorities and a summary of their specific requirements. Other classifications available on request, please contact Felm for details.

Table 9

Standards for TEFV and open drip proof				
Classifying authority	Service	Rotating Machines Ambient temp ° C	Permissible Temp rise K Class F	Key special requirements Witnessed tests for essential service
Lloyds Register of Shipping (LRS)	Non-essential Essential	45	95	>100kW
Det Norske Veritas (DNV)	Non-essential Essential	45	100	>100kW
Germanischer Lloyd (GL)	Non-essential Essential	45	100	>50kW
American Bureau of Shipping (ABS)	Non-essential Essential	45	95	>100kW
Korean Register of Shipping (KRS)	Non-essential Essential	45	95	All motors
Chinese Classification Societies (CCS)	Non-essential Essential	45	95	>50kW
Russian Shipping (RS)	Non-essential Essential	45	100	All motors
Bureau Veritas (BV)	Non-essential Essential	45	100	>100kW
Registro Italiano Navale (RINA)	Non-essential Essential	45	100	>100kW
Nippon Kaiji Kyokai (NKK)	Non-essential Essential	45	100	> 100kW

All Electric Motors are tested and FELM’s test Reports are provided for all the machines supplied. The mentioned documentations are supplied with the Technical Documentation.

- ≤99KW all the machine intended for “Essential Services” are to be type approved and manufacturer certificated shall be issued.
- For all rotating machine for “Non Essential Services”, individual manufacturer certificate shall be issued.
- ≥100KW intended for “Essential Services” are to be type approved by Lloyd’s Register classifying authority.

EXAMPLE

(below data may change based on Fincantieri Hull number ref)

General Technical specifications

- Asynchronous squirrel cage motors comply with IEC standard: IEC 60034-1, IEC 60034-30 and IEC 60092-301.
- Efficiency class IE3 in accordance to IEC 60034-30.
- Motors type "FM3" for DOL starting.
- Motors type "FM3VP" for inverter duty.
- Motors type "FMD" for two speed motors – IE1
- Cast-Iron housing, main terminal box with blind plate without threaded holes.
- Bigger main terminal box for framesize 280 & 315.
- Duty S1.
- Enclosure IP55 (IP56 only on request by customer for motors installed on weather deck) .
- Cooling IC411.
- Insulation class F.
- Temperature rise class F.
- Ambient temperature -25°C + 45°C.
- Tropicalization for humidity 90%.
- Drain holes ≥160 frames.
- Heaters V220/1ph with terminals in separate aux. t.box with junction type NI 884824C fitted as below:
 - For all motors ≥40KW.
 - For motors on weather deck with IP56.
- Terminal board with 6 pin.
- Connection: Star - V.690Y/60Hz, DOL Starting.
- Painting process: according to painting cycle 0600000017 Final colour RAL7035 thickness as below:
 - For motors framesize ≤132 total thickness 100 Micron.
 - For motors framesize ≥160 total thickness 120 Micron.
- Main Terminal box with blind plate, without threaded holes.
- Aux. terminal box, were fitted, with junction type NI 884824C.
- Earthing bolt: N°1 external on housing and N°1 inside main terminal box.
- Ball bearings for all frames.
- Ball bearings "grease packed for life" ≤225 frames.
- Grease lubrication with grease nipples ≥250 frames.
- Two speed motors will have two separate windings.
- Inverter duty motors will have reinforced windings suitable to resist of a voltage peak of V2500 as per IEC60034-25 curve B.
- Classifying authority: Lloyd's Register.
- ≤99KW all the machine intended for "Essential Services" are to be type approved and manufacturer certificate shall be issued.
- For all rotating machine for "Non Essential Services", individual manufacturer certificate shall be issued.
- ≥100KW intended for "Essential Services" are to be type approved by classifying authority.
- All different data, refer to FELM Marine motors catalogue Hull 6319.
- Noise level at 1m on no load max 85dB(A)
- 3xPTC (150°C) with terminals in main T.box shall be fitted in windings as per following details:
 - As standard ≥ framesize 160 .
 - For all the motors for "Essential Services" .
 - For all motors inverter duty.

Marine motor general features	
	Cast iron frame 80-355.
Voltage/Frequency	V690Y/60Hz - terminal board with 6 pin (other voltages available on request).
Efficiency	IE3.
Type FM3	DOL starting motors.
Type FM3VP	Inverter duty motors with reinforced windings.
Amb temp	-25° C +45° C.
Enclosure	cast iron frame standard IP55 (IP56 or IP66 only on request) .
Main t.box	Main t.box provided with blind plate without holes .
Aux t.box	When fitted is provided with junction type NI 884824C (plastic cable gland available only on request).
Cooling method	IC411 TEFV Totally Enclosed Fan Ventilated.
T-box position	On Top - with bigger main t.box for framesize 280 & 315.
Lubrication	≤frames 225 ball bearing greased for life / ≥ frames 250 through grease nipple.
Vibrations	Grade A.
Bearings	All frame with ball bearings (roller bearing available on request).
Bearings	Frame ≥280 Inverter duty motors provided with insulated bearing at NDE .
Drain holes	≥ Frames 160.
Temperaturerise	Class F.
Insulation class	Class F.
Duty cycle	S1 continuous rated.
Earth bolt	Provided in main t.box and on motor frame.
Heaters V220/1ph	≥40kw in aux t.box. for Essential Service and IP56 motors. (When for Non Essential Services only if requested by the customer.
PTC(150° C)	In main t.box. As standard for ≥Framesize 160.
Thermal Protection	For all motors essential service and all motors for inverter duty.
Final colour	RAL7035 (other colours available on request)

Insulation and thermal rating

Felm motors are manufactured using Class F insulating materials, giving a maximum operating temperature, including ambient of 155° C.

Motor Winding Insulation Level:

- < 500V: at least 1.500 V.
- > 500V: at least 2.500 V.

Motor ratings depend upon:

- ambient temperature
- type of service
- maximum operating temperate, i.e. Class F (155° C)
- certifying authorities' special arrangements
- supply variations, i.e. tolerance on voltage and frequency

To simplify selection, it is assumed that standard supply conditions of voltage are +/-10%. Refer to output data on technical table.

Ambient temperatures

If low (< -30° C) or high (> + 60° C), ambient temperatures are to be experienced, it may be necessary to use special materials, i.e. grease, shaft steel etc.

This depends largely on the operational requirements of the vessel or its equipment.



CONTATCS

Head Quarter

FELM srl

Via Morandi (Industrial Area)

20010 Inveruno (Mi) Italy

Tel. +39 02 97 289 454

Tel. +39 02 97 288 320

Fax +39 02 97 289 923

E-mail home@felm.it

FELM Office Middle East

Jebel Ali Free Zone, Warehouse no. FZS1-BM07,

PO Box 263632, Dubai, United Arab Emirates

Office Ph. +971 (04) 887 9767

mobile +971 50 550 1322

Email: ayman.abdallah@felm.it

FELM Office Germany

Heinrich-Busold-Strasse 47

D-61169 Friedberg (Hessen), Germany

Tel (Off): +49-6031-721606

Mobile: +49-172-6729011

Fax: +49-6031-721610

Email: Jayant@jk-conrep.de

FELM Office China

Add: Room 1002, Building 3#,

No 139 Rd. SongShan,

Jianye, Nanjing, Jiangsu, China

Fax: +86-25-87797622

Tel: +86-15077829999

Email: lidongming1974@vip.sina.com

FELM Office UK

The Foundry, Wadebridge

Cornwall, PL27 7JP

United Kingdom

Tel (Off): +441208 816543

Email: sales@felm.co.uk

WORLD WIDE SERVICE

Mobile +39 355 69 53 804

E-mail service@felm.it





Electric Motors - www.felm.it



NEMA MG-1 MOTORS

CC Number by DOE – Nema Premium Efficiency tab 12-12

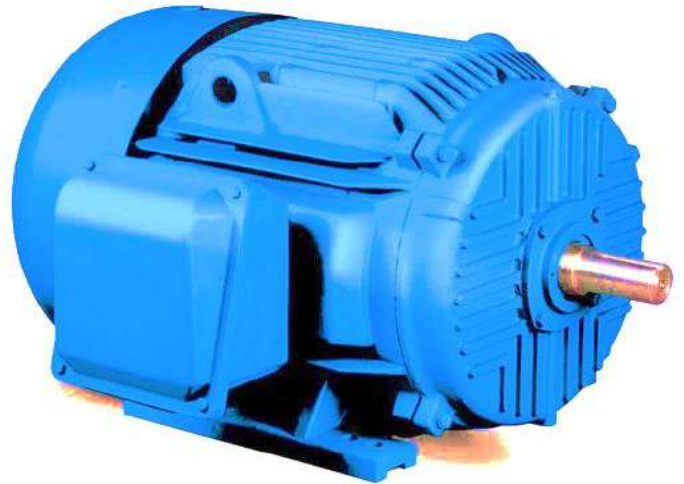

CERTIFICATE OF COMPLIANCE

Certificate Number E481791
Report Reference E481791-20210430
Issue Date 2021-APRIL-30

Issued to: FELM srl
Via MorandiInverunoITMIIT20001

This certificate confirms that representative samples of Motors for Appliance Applications - Component See Addendum Page

Have been investigated by UL in accordance with the component requirements in the Standard(s) indicated on this Certificate. UL Recognized components are incomplete in certain constructional features or restricted in performance capabilities and are intended for installation in complete equipment submitted for investigation to UL LLC.

Standard(s) for Safety: UL 1004-1- Standards for Rotating Electrical Machines - General Requirements.
CSA C22.2 No. 100-14- Standard for Motors and generators

Additional Information: See the UL Online Certifications Directory at <https://iq.ulprospector.com> for additional information.

This Certificate of Compliance does not provide authorization to apply the UL Recognized Component Mark. Only the UL Follow-Up Services Procedure provides authorization to apply the UL Mark.

Only those products bearing the UL Recognized Component Mark should be considered as being UL Certified and covered under UL's Follow-Up Services.

Look for the UL Recognized Component Mark on the product.

Dina Maheshwari, Director North America Certification Program

UL LLC

Any information and documentation involving UL Mark services are provided on behalf of UL LLC (UL) or any authorized licensee of UL LLC. Customer Service Representative at <http://ul.com/about/ulcontact>

CERTIFICATE OF COMPLIANCE

Certificate Number E481791
Report Reference E481791-20210430
Issue Date 2021-APRIL-30

This is to certify that representative samples of the product as specified on this certificate were tested according to the current UL requirements.

80G-2,80G-4,***80K-2,***90L-2,***90L-4,***90L-6,***90S-2,***90S-4,***90S-6,***100L-2,***100L-4,***100L-6,***100LX-4,***112M-2,***112M-4,***112M-6,***132M-4,***132M-6,***132MX-6,***132S-2,***132S-4,***132S-6,***132SX-2,***160L-2,***160L-4,***160L-6,***160LX-2,***160LX-4,***160LX-6,***160LY-2,***180L-4,***180L-6,***180M-2,***180M-4,***200L-2,***200L-4,***200L-6,***200LX-2,***200LX-6,***225M-2,***225M-4,***225M-6,***225S-4,***250M-2,***250M-4,***250M-6,***280M-2,***280M-4,***280M-6,***280S-2,***280S-4,***280S-6,***315L-2,***315L-4,***315L-6,***315LX-2,***315LX-4,***315LX-6,***315M-2,***315M-4,***315M-6,***315S-2,***315S-4,***315S-6,***355L-2,***355L-4,***355L-6,***355LX-2,***355LX-4,***355LX-6,***355LY-2,***355LY-4,***355LY-6,***355M-2,***355M-4,***355M-6,***355MX-6,***355MY-6,***400M-2,***400M-4,***400M-6.

****143T-2,****143T-4,****145T-2,****145T-4,****145T-6,****182T-2,****182T-4,****182T-6,****184T-2,****184T-4,****184T-6,****213T-2,****213T-4,****213T-6,****215T-2,****215T-4,****215T-6,****254T-2,****254T-4,****254T-6,****256T-2,****256T-4,****256T-6,****284T-4,****284T-6,****284TS-2,****284T-4,****288T-6,****288TS-2,****324T-4,****324T-6,****324TS-2,****326T-4,****326T-6,****326TS-2,****364T-4,****364T-6,****364TS-2,****365T-4,****365T-6,****365TS-2,****404T-8,****405T-4,****405T-6,****405TS-2,****444T-4,****444T-6,****444TS-2,****445T-4,****445T-6,****445TS-2,****447T-4,****447T-6,****447TS-2,****449T-4,****449T-6,****449TS-2,****504/5T-4,****504/5T-6,****586/7T-4,****586/7T-6,FWMP 400LY-4.

Dina Maheshwari, Director North America Certification Program

UL LLC

Any information and documentation involving UL Mark services are provided on behalf of UL LLC (UL) or any authorized licensee of UL. For questions, please contact a local UL Customer Service Representative at <http://ul.com/about/ulcontact>





FELM US Electric Motors

General

FELM NEMA motors FT series, TEFC, is designed and manufactured according with the latest version of NEMA MG1 - 2016 construction. TEFC motor with design B meets MG1 standard 12-12.

All motors are with UL certificate, and suitable for VFD application. *1

All motors are with service factor 1.15

F1 & F2 are interchangeable from 143T to 449T.

Frame 143T through to N6808, 3600, 1800, 1200 and 900RPM, continuous duty at 40°C, 230/460V 60HZ. 575V available on request.

Bearings

Oversized, world top brand of life sealed with pre-lubricated ball bearing up to 280T, and re-greaseable bearings from 254T and up.

World top brand of high performance grease applied for longer operation life.

Grease pipes and relief vents with plug are provided for all open bearing construction.

Insulation

All motors are with excellent insulation system class F, temperature rise B.

Conduit Box

Oversized conduit box made of fabricated steel provides big space for connections.

Diagonally and rotatable in 90° positions.

Cast iron conduit box from frame N5007 and up.

***1 Meets NEMA MG1 part 31, CT 20:1 VT 4:1, wider range available on request (also depends on the inverter selection)**

Cooling Fan

Increased safety external cooling fan meets non-sparking feature, and aluminium fan/steel fan available on request.

Forced ventilation unit available on request for VFD operation.

Grounding and bearing protection

Aegis shaft grounding ring available on request.

Insulated bearing or insulated bracket (size 447 and up) available on request.

Auxiliaries

Space heater, Wind RTDs, bearing RTDs, SPM vibration detecting available on request or specific applications.

Cooling

Cooling air flows from the non-drive-end to the drive-end. The fan is independent of the direction of rotation of the motor. **When the motor is installed, air flow should not be impeded to enter in the motor cowl.** The following minimum dimension BL should be adopted. Cooling are flown from the NDE to the DE side. The minimum space between the cooling fan and the wall or barrier must be kept for sufficient cooling.

Frame Size	Dimension BL (mm)
140T	20
182T-215T	30
254T-286T	40
324T-400T	50
444T and up	65

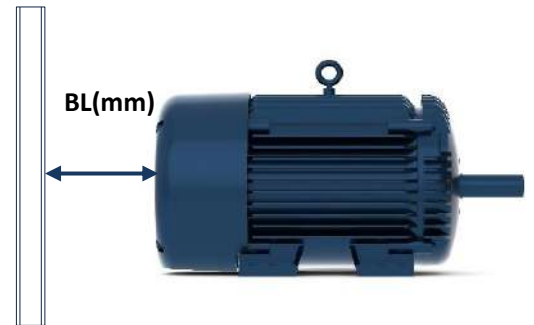

Ambient Temperature and Altitude

The rated outputs specified in the datasheet are based on ambient temperature of 40°C (104°F) and at 1000m (3300ft) altitude. Please refer to the multiplication factors in the table, in case of different ambient temperature and/or altitude.

Ambient temperature	Temperature factor	Altitude above sea level	Ambient factor
30°	1.06	3300 ft	1
35°	1.03	4900 ft	0.98
40°	1	6600 ft	0.94
45°	0.97	8200 ft	0.91
50°	0.93	9900 ft	0.87
55°	0.88	11500 ft	0.82
60°	0.82	13000 ft	0.77

$$\text{Effective Power} = (\text{Rated Power}) * (\text{Temperature factor}) * (\text{Altitudinal factor})$$

Typical torque-speed curve is shown in the below

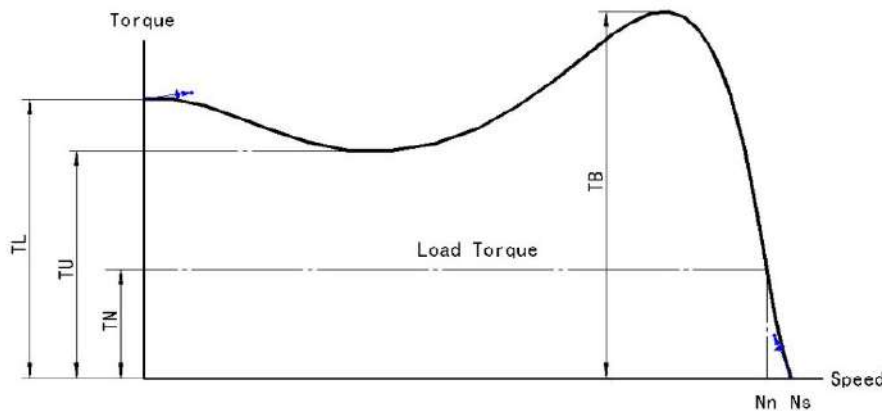

- TN=Full load torque**
- TL=Locked rotor torque**
- TU=Pull up torque**
- TB= Breakdown torque**
- Nn=Full load speed**
- Ns= Synchronous speed**

FELM motor with design B has the locked rotor torque (LRC) performance meets MG1 standard value or larger.

Variable Frequency Drive application

VFD becomes popular in many applications, providing small starting current, slow starting speed, and significant energy saving. The following shall be considered with apply standard motor as VFD.

1. Operation

Voltage(Ampere) fed by VFD is not pure sinusoidal which could affect the motor performance on loss, vibration and noise. In additional, the changes on distribution of losses could affect the temperature balance inside the motor, and lead to higher bearing temperature.

2. Frequency range

The actual speed of the motor driven by inverter could be big different than the rated. Make sure do not exceed the maximum allowed speed or critical speed of the motor. Refer to us if necessary.

The followings shall be checked and considered when the inverter runs the motor at a speed higher than rated.

Maximum torque of the motor

Bearing construction

Lubrication

Critical speed

Shaft seals

Ventilation

Fan noise

The motor may lose its cooling capacity when run at low speed, which leads to higher winding temperature and bearing temperature. A forced ventilator can help to increase the cooling. The Check of lubrication performance at low speed is also necessary.

3. Lubrication

Usually the effectiveness of lubrication can be indicated by measuring bearing temperature. The interval of lubrication shall be reduced when the bearing temperature higher than 80°C (176°F).

If the motor continuously runs at low speed, as well as low ambient temperature, the standard grease may be not sufficient and special grease may required. Consult FELM for more information.

When the motor equipped with life sealed bearing, the lift time may be different than standard application.

4. Insulation protection

Most of inverter has the IGBT unit, with fast switching, steep voltage pulses and cable reflections. This will provide large stress to winding insulation of the motor. The protection solution shall be considered as per table below.

Voltage	Motor nominal Pn or frame size		
	Pn<100HP	Pn ≥ 100Hp or ≥ 449T	Pn ≥ 400Hp or > 5800T
Un ≤ 500V	Standard motor	Standard motor	Standard motor
		+ Insulated N-bearing	+ Insulated N-bearing
			+ Common mode filter
Un ≤ 600V	Standard Motor	Standard motor	Standard motor
	+ du/dt filter	+ Insulated N-bearing	+ Insulated N-bearing
	OR	+ du/dt filter	+ du/dt filter
	Reinforced insulation	OR	Light Common mode filter
		Reinforced insulation	OR
		+ Insulated N-bearing	Reinforced insulation
			+ Insulated N-bearing
Un ≤ 690V	Reinforced insulation	Reinforced insulation	Reinforced insulation
	+ du/dt filter	+ Insulated N-bearing	+ Insulated N-bearing
		+ du/dt filter	+ du/dt filter
			Light Common mode filter

5. Shaft current protection

The motor shall avoid to have shaft voltage larger than 300mv, otherwise the risk of bearing damaging is rising. Aegis grounding ring or similar device, insulated bearing or insulated bracket are available on request, to protect the bearing.

6. Cable, grounding and EMC

The motor shall be connected to inverter by shielded cable and EMC gland.

TEFC Design B Premium efficiency Standard Motor 230/460/575V. 60Hz. – FT Series

Hp	kW	RPM	Frame	Full Load Amps		Full Load Torque Lb.Ft.	Efficiency %	Power Factor	Torque(%)		Sound Power Level dB(A)
				230/460V or 460V	575V				Locked Rotor	Break - down	
1	0.75	3460	143T	2.92/1.46	1.16	1.5	77	0.84	310	350	70
1	0.75	1760	143T	2.98/1.49	1.19	3	85.5	0.74	275	300	65
1	0.75	1160	145T	3.16/1.58	1.27	4.6	82.5	0.72	170	265	64
1.5	1.1	3490	143T	3.92/1.96	1.57	2.2	84	0.85	200	270	70
1.5	1.1	1755	145T	4.2/2.1	1.68	4.4	86.5	0.78	275	300	66
1.5	1.1	1180	182T	4.38/2.19	1.75	6.6	87.5	0.73	180	280	67
2	1.5	3490	145T	5.12/2.56	2.05	3.0	85.5	0.86	200	260	70
2	1.5	1755	145T	5.58/2.79	2.23	6.0	86.5	0.78	250	300	66
2	1.5	1180	184T	5.74/2.87	2.3	9.0	88.5	0.73	180	280	67
3	2.2	3500	182T	7.34/3.67	2.94	4.4	86.5	0.89	200	280	75
3	2.2	1760	182T	7.44/3.72	2.97	8.8	89.5	0.84	215	250	68
3	2.2	1185	213T	8.8/4.4	3.53	13.1	89.5	0.72	155	230	67
5	3.7	3500	184T	11.8/5.9	4.7	7.5	88.5	0.90	140	250	75
5	3.7	1755	184T	12.2/6.1	4.88	14.9	89.5	0.86	215	250	68
5	3.7	1180	215T	14.4/7.2	5.77	22.2	89.5	0.73	155	230	67
7.5	5.5	3520	213T	17.2/8.6	6.86	11.0	89.5	0.90	140	250	77
7.5	5.5	1770	213T	18.6/9.3	7.44	22.0	91.7	0.82	180	250	70
7.5	5.5	1185	254T	20.8/10.4	8.3	32.8	91	0.73	160	230	70
10	7.5	3520	215T	23.2/11.6	9.28	15.1	90.2	0.90	150	250	77
10	7.5	1770	215T	24.8/12.4	9.9	29.9	91.7	0.83	180	250	70
10	7.5	1185	256T	28.4/14.2	11.3	44.7	91	0.73	160	220	70
15	11	3550	254T	34.4/17.2	13.8	21.9	91	0.89	170	240	87
15	11	1780	254T	36.4/18.2	14.6	43.7	92.4	0.83	160	220	75
15	11	1185	284T	37.6/18.8	15.1	65.6	91.7	0.82	150	230	80
20	15	3545	256T	46.4/23.2	18.6	29.9	91	0.89	150	210	88
20	15	1780	256T	48.2/24.1	19.3	59.6	93	0.84	160	220	75
20	15	1185	286T	50/25	20	89.5	91.7	0.82	140	220	80
25	18.5	3555	284TS	57.6/28.8	23	36.8	91.7	0.89	140	220	88
25	18.5	1775	284T	58.4/29.2	23.3	73.7	93.6	0.85	150	220	85
25	18.5	1190	324T	67.4/33.7	27	109.9	93	0.75	150	230	81



TEFC Design B Premium efficiency Standard Motor 230/460/575V 60Hz – FT series

Hp	kW	RPM	Frame	Full Load Amps		Full Load Torque Lb.Ft.	Efficiency %	Power Factor	Torque(%)		Sound Power Level dB(A)
				230/460V or 460V	575V				Full Load	Full Load	
30	22	3555	286TS	68.4/34.2	27.4	43.7	91.7	0.89	140	220	88
30	22	1775	286T	69.4/34.7	27.8	87.6	93.6	0.86	150	220	85
30	22	1185	326T	77.2/38.6	30.8	131.2	93	0.78	140	210	81
40	30	3555	324TS	92.6/46.3	37	59.6	92.4	0.88	150	230	89
40	30	1780	324T	93.0/46.5	37.2	119.1	94.1	0.86	160	230	85
40	30	1190	364T	101.4/50.7	40.5	178.2	94.1	0.79	140	230	82
50	37	3555	326TS	113.4/56.7	45.4	73.6	93	0.89	150	230	90
50	37	1780	326T	114.2/57.1	45.7	146.9	94.5	0.87	160	240	85
50	37	1190	365T	125/62.5	50	219.7	94.1	0.80	145	230	83
60	45	3570	364TS	137.2/68.6	54.9	89.1	93.6	0.88	150	210	89
60	45	1785	364T	138/69	55.3	178.2	95	0.86	140	200	88
60	45	1190	404T	140/70	56.2	267.2	94.5	0.85	145	220	85
75	55	3570	365TS	167.6/83.8	67	108.9	93.6	0.90	140	210	89
75	55	1780	365T	168/84	67.3	218.4	95.4	0.87	150	220	88
75	55	1190	405T	172/86	68.7	326.6	94.5	0.86	145	220	85
100	75	3575	405TS	224/112	89.6	148.3	94.1	0.89	150	250	*
100	75	1790	405T	226/113	90.4	296.1	95.4	0.87	150	230	*
100	75	1190	444T	232/116	96.7	445.4	95	0.85	135	220	*
125	90	3585	444TS	264/132	106	177.4	95	0.91	130	230	*
125	90	1790	444T	276/138	110	355.3	95.4	0.87	130	220	*
125	90	1190	445T	290/145	116	534.5	95	0.85	135	220	*
150	110	3585	445TS	322/161	129	216.8	95	0.91	140	230	*
150	110	1790	445T	336/168	134	434.3	95.8	0.87	130	220	*
150	110	1190	447T	344/172	141	653.3	95.8	0.85	140	240	*
200	150	3585	447TS	434/217	173	295.7	95.4	0.91	150	230	*
200	150	1790	447T	456/228	182	592.2	96.2	0.86	120	220	*
200	150	1190	449T	460/230	187	890.8	95.8	0.85	120	210	*
250	185	3585	449TS	268	216	364.7	95.8	0.91	200	250	*
250	185	1790	449T	282	227	730.4	96.2	0.86	200	250	*
250	185	1190	449T	288	241	1098.7	95.8	0.85	175	250	*
300	220	3585	449TS	320	257	443.5	95.8	0.91	200	250	*
300	220	1790	449T	332	266	888.3	96.2	0.87	200	250	*

*= data on request

Dimensions FT series

FELM NEMA TEFC Design B premium efficiency motors, foot mount, F1

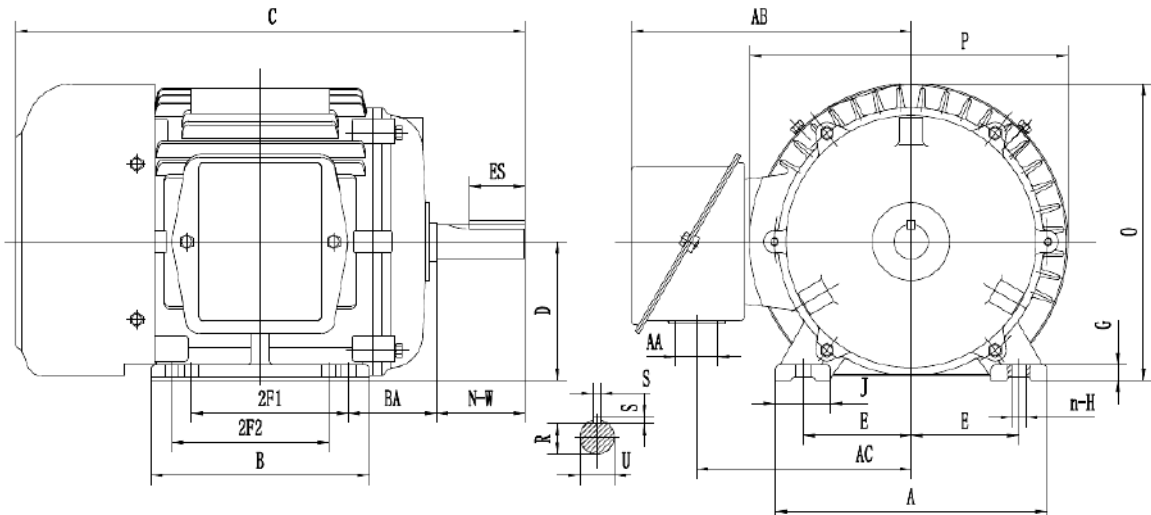

Size	Dimensions (Inches)																				
	A	B	C	D	E	n-H	2F1	2F2	G	J	N-W	BA	P	R	S	U	ES	AA	AB	AC	O
143T	6.93	5.55	13	3.5	2.75	8-0.34	4	4	0.4	1.42	2.25	2.25	8	0.77	0.188	0.875	1.41	1	7.2	5.5	7.5
145T	6.93	6.55	14	3.5	2.75	8-0.34	5	5	0.4	1.42	2.25	2.25	8	0.77	0.188	0.875	1.41	1	7.2	5.5	7.5

Frame 182T 184T

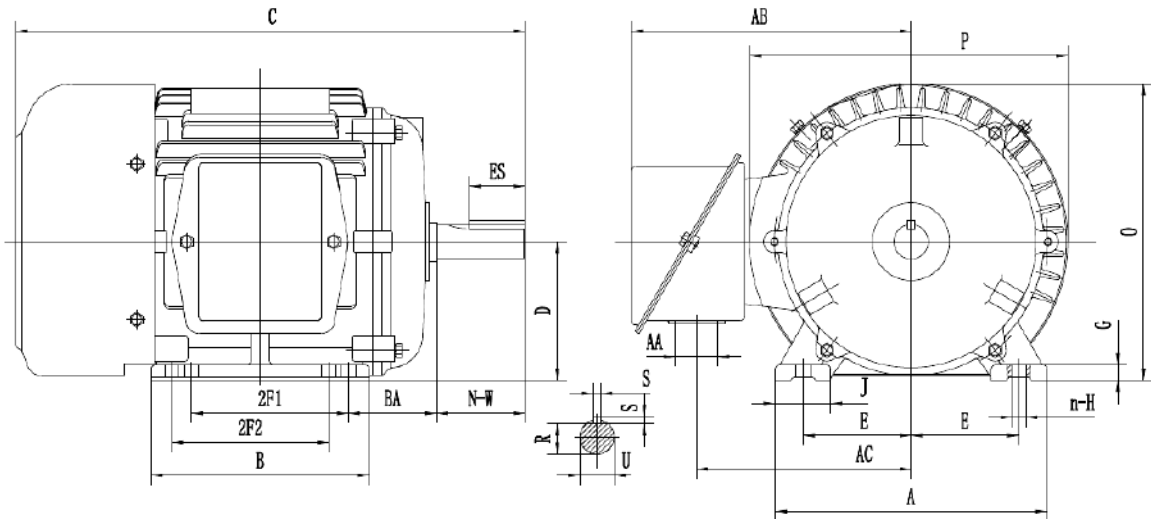

Size	Dimensions (Inches)																					
	A	B	C	D	E	n-H	2F1	2F2	G	J	N-W	BA	P	R	S	U	ES	AA	AB	AC	O	T
182T	9	5.6	15	4.5	3.75	4-0.41	4.5	NA	0.45	1.6	2.75	2.75	9.87	0.98 6	0.25	1.12 5	1.78	1	8.2	6.5	9.27	1.73
184T	9	6.6	16	4.5	3.75	8-0.41	4.5	5.5	0.45	1.6	2.75	2.75	9.87	0.98 6	0.25	1.12 5	1.78	1	8.2	6.5	9.27	1.73

Note:

Dimensions subject to change, please ask for dimensional drawing when ordering.

Dimensions FT series

FELM NEMA design B premium efficiency motors, foot mount, F1

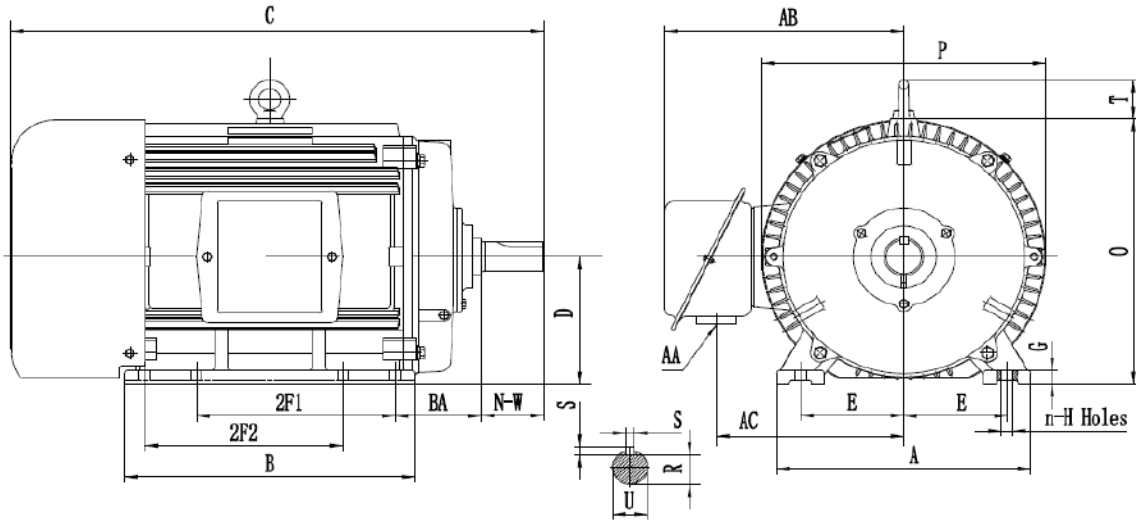

Size	Dimensions (Inches)																					
	A	B	C	D	E	n-H	2F1	2F2	G	J	N-W	BA	P	R	S	U	ES	AA	AB	AC	O	T
213T	1.4	7	18	5.2 5	4.25	4-0.41	5.5	NA	0.6	1.8	3.38	3.5	11.9	1.20 1	0.31 2	1.37 5	2.4 1	1	9.6	7.9	10.9	1.7 3
215T	14	8.5	19.5	5.2 5	4.25	4-0.41	7	NA	0.6	1.8	3.38	3.5	11.9	1.20 1	0.31 2	0.37 5	2.4 1	1	9.6	7.9	10.9	1.7 3
254T	12.2	12.8	26.7	6.2 5	5	8-0.53	8.25	8.25	0.5 3	2.56	4	4.2 5	14.2	1.41 6	0.37 5	1.62 5	2.9 1	1.25	12.7	9.5	13.3 5	2.0 5
256T	12.2	13.9 8	27.8	6.2 5	5	8-0.53	10	10	0.5 3	2.56	4	4.2 5	14.2	1.41 6	0.37 5	1.62 5	2.9 1	1.25	12.7	9.5	13.3 5	2.0 5
284TS	13.8	15.7 5	28.9	7	5.5	8-0.53	9.5	9.5	0.5 5	2.76	3.25	4.7 5	15.4	1.41 6	0.37 5	1.62 5	1.9 1	1.5	13.5	10.2	14.8 5	2.0 5
284T	13.8	15.7 5	30.2	7	5.5	8-0.53	9.5	9.5	0.5 5	2.76	4.62	4.7 5	15.4	1.59 1	0.5	1.87 5	3.2 8	1.5	13.5	10.2	14.8 5	2.0 5
286TS	13.8	16.9 3	30	7	5.5	8-0.53	11	11	0.5 5	2.76	3.25	4.7 5	15.4	1.41 6	0.37 5	1.62 5	1.9 1	1.5	13.5	10.2	14.8 5	2.0 5
286T	13.8	16.9 3	31.3	7	5.5	8-0.53	11	11	0.5 5	2.76	4.62	4.7 5	15.4	1.59 1	0.5	1.87 5	3.2 8	1.5	13.5	10.2	14.8 5	2.0 5
324TS	14.2	16.3 8	31.1	8	6.25	8-0.66	10.5	10.5	0.8 6	2.85	3.75	5.2 5	17.2	1.59 1	0.5	1.87 5	2.0 3	2	14.2	11.3 4	16.6 6	2.4 4
324T	14.2	16.3 8	32.6	8	6.25	8-0.66	10.5	10.5	0.8 6	2.85	5.25	5.2 5	17.2	1.84 5	0.5	2.12 5	3.9 1	2	14.2	11.3 4	16.6 6	2.4 4
326TS	14.2	17.5 6	32.3	8	6.25	8-0.66	12	12	0.8 6	2.85	3.75	5.2 5	17.2	1.84 5	0.5	1.87 5	2.0 3	2	14.2	11.3 4	16.6 6	2.4 4
326T	14.2	17.5 6	33.7	8	6.25	8-0.66	12	12	0.8 6	2.85	5.25	5.2 5	17.2	1.59 1	0.5	2.12 5	3.9 1	2	14.2	11.3 4	16.6 6	2.4 4
364TS	17	18.2	34.1	9	7	8-0.66	11.2 5	11.2 5	1.1 7	3	3.75	5.8 8	19.4	1.59 1	0.5	1.87 5	2.0 3	3	16.3	12.3	18.7 7	2.8 3
364T	17	18.2	36.2 3	9	7	8-0.66	11.2 5	11.2 5	1.1 7	3	5.88	5.8 8	19.4	2.02 1	0.62 5	2.37 5	4.2 8	3	16.3	12.3	18.7 7	2.8 3
365TS	17	20	35.9	9	7	8-0.66	12.2 5	12.2 5	1.1 7	3	3.75	5.8 8	19.4	1.59 1	0.5	1.87 5	2.0 3	3	16.3	12.3	18.7 7	2.8 3
365T	17	20	38.0 3	9	7	8-0.66	12.2 5	12.2 5	1.1 7	3	5.88	5.8 8	19.4	2.02 1	0.62 5	2.37 5	4.2 8	3	16.3	12.3	18.7 7	2.8 3
404T	19.1 3	14.9 6	36.4	10	8	4-0.81	12.2 5	NA	1.1 8	3.15	7.25	6.6 2	21.5	2.45	0.75	2.87 5	6.1	3	18.1 1	15.6 8	21.0 2	2.8 3
405TS	19.1 3	16.5 3	34.8	10	8	4-0.81	13.7 5	NA	1.1 8	3.15	4.25	6.6 2	21.5	1.84 5	0.5	2.12 5	2.7 8	3	18.1 1	15.6 8	21.0 2	2.8 3
405T	19.1 3	16.5 3	37.8	10	8	4-0.81	13.7 5	NA	1.1 8	3.15	7.25	6.6 2	21.5	2.45	0.75	2.87 5	6.1	3	18.1 1	15.6 8	21.0 2	2.8 3

Dimensions FT series

FELM NEMA design B premium efficiency motors, foot mount, F1

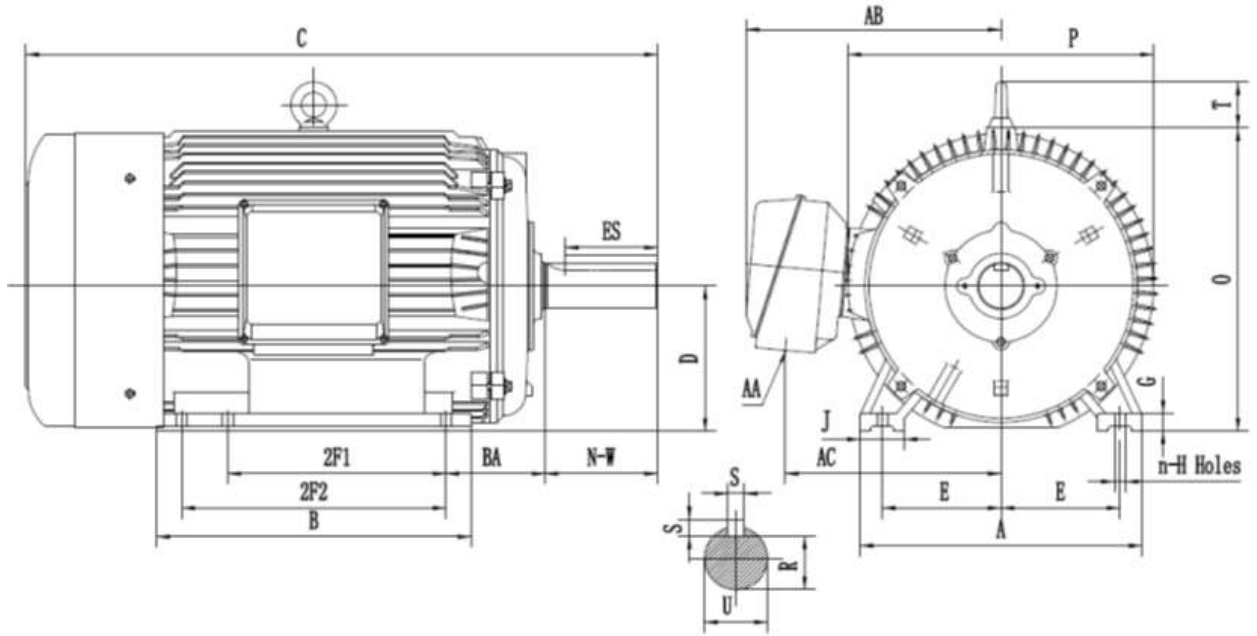

Size	Dimensions (Inches)																					
	A	B	C	D	E	n-H	2F1	2F2	G	J	N-W	BA	P	R	S	U	ES	AA	AB	AC	O	T
444TS	22	25.5 9	47.0 5	11	9	4- 0.81	14. 5	NA	1.3 8	3.35	475	7.5	23.1	2.02 1	0.62 5	2.37 5	3.0 3	2X 3	19. 5	16.3	23	3.5
444T	22	25.5 9	50.7 9	11	9	4- 0.81	14. 5	NA	1.3 8	3.35	8.5	7.5	23.1	2.88	0.87 5	3.37 5	6.9 1	1X 3	19. 5	16.3	23	3.5
445TS	22	25.5 9	47.0 5	11	9	6- 0.81	14. 5	16. 5	1.3 8	3.35	4.75	7.5	23.1	2.02 1	0.62 5	2.37 5	3.0 3	2X 3	19. 5	16.3	23	3.5
445T	22	25.5 9	50.7 9	11	9	6- 0.81	14. 5	16. 5	1.3 8	3.35	8.5	7.5	23.1	2.88	0.87 5	3.37 5	6.9 1	2X 3	19. 5	16.3	23	3.5
447TS	22	30.7 1	52.1 7	11	9	6- 0.81	16. 5	20	1.3 8	3.35	4.75	7.5	23.1	2.02 1	0.62 5	2.37 5	3.0 3	2X 3	19. 5	16.3	23	3.5
447T	22	30.7 1	55.9 1	11	9	6- 0.81	16. 5	20	1.3 8	3.35	8.5	7.5	23.1	2.88	0.87 5	3.37 5	6.9 1	2X 3	19. 5	16.3	23	3.5
449TS	22	30.7 1	52.1 7	11	9	6- 0.81	20	25	1.3 8	3.35	4.75	7.5	23.1	2.02 1	0.62 5	2.37 5	3.0 3	2X 3	19. 5	16.3	23	3.5
449T	22	30.7 1	55.9 1	11	9	6- 0.81	20	25	1.3 8	3.35	8.5	7.5	23.1	2.88	0.87 5	3.37 5	6.9 1	2X 3	19. 5	16.3	23	3.5

Note:

Dimensions subject to change, please ask for dimensional drawing when ordering.

NAMEPLATE FT SERIE

FELM *srl* www.felm.it Premium Efficiency Motor

MODEL OMN 182T-2	SER.		
CAT# FT 182T			
FRAME 182T	POLES 2	DES. B	CODE K DUTY CONT TYPE
PH 3	INS. F	ENCL TEFC	AMB °C 45 RISE 80°C ALTITUDE 1500M
MTG V18	IP 55	IC 411	WT LBS/kg MTH/YR MFG
Hz 60	VOLTS 460		Hz 50 VOLTS 380
HP 3	F.L.AMPS 3.67		HP 2 F.L.AMPS 3.1
kW 2.2	RPM 3500	S.F. 1.15	kW 1.5 RPM 2920 S.F. 1.15
NOM.EFF. 86.5	PF 0.89		NOM.EFF. 84.2 PF 0.87
SHAFT END BRG 6206 2ZC3			OPP. END BRG 6205 2ZC3
Heater: 120V 30W			

Y L1 — (T1) — (T6)

L2 — (T2) — (T4)

L3 — (T3) — (T5)

CCxxx Lxxxx

All data (technical, dimensions, etc..) listed in the tables are indicative and not binding. The guaranteed values are upon request. Felm srl reserves the right to change the project, the technical characteristics and dimensions at any time without previous notice.



CONTACTS

Head Quarter

FELM srl

Via Morandi (Industrial Area)

20001 Inveruno (Mi) Italy

Tel. +39 02 97 289 454

Tel. +39 02 97 288 320

Fax +39 02 97 289 923

E-mail home@felm.it



WORLD WIDE SERVICE

Mobile +39 355 69 53 804

E-mail service@felm.it

FELM Office Middle East

Jebel Ali Free Zone, Warehouse no. FZS1-BM07,

PO Box 263632, Dubai, United Arab Emirates

Office Ph. +971 (04) 887 9767

mobile +971 50 550 1322

Email: ayman.abdallah@felm.it

FELM Office Germany

Heinrich-Busold-Strasse 47

D-61169 Friedberg (Hessen), Germany

Tel (Off): +49-6031-721606

Mobile: +49-172-6729011

Fax: +49-6031-721610

Email: Jayant@jk-conrep.de

FELM Office China

Add: Room 1002, Building 3#,

No 139 Rd. SongShan,

Jianye, Nanjing, Jiangsu, China

Fax: +86-25-87797622

Tel: +86-15077829999

Email: lidongming1974@vip.sina.com

FELM Office UK

The Foundry, Wadebridge

Cornwall, PL27 7JP

United Kingdom

Tel (Off): +441208 816543

Email: sales@felm.co.uk



ISO 14001



Lloyd's Register





Electric Motors - www.felm.it

NEMA PREMIUM EFFICENCY IEC UL Safety Certificate

CC N. 356B



CERTIFICATE OF COMPLIANCE

Certificate Number E481791
Report Reference E481791-20210430
Issue Date 2021-APRIL-30

Issued to: FELM srl
Via MorandiInverunoITMIIT20001

This certificate confirms that representative samples of Motors for Appliance Applications - Component See Addendum Page

Have been investigated by UL in accordance with the component requirements in the Standard(s) indicated on this Certificate. UL Recognized components are incomplete in certain constructional features or restricted in performance capabilities and are intended for installation in complete equipment submitted for investigation to UL LLC.

Standard(s) for Safety: UL 1004-1- Standards for Rotating Electrical Machines -
Gen
CSA
gene

Additional Information: See <https://>

This Certificate of Compliance does not provide the UL Follow-Up Services Procedure provided

Only those products bearing the UL Recognized Component Mark and covered under UL's Follow-Up Services.

Look for the UL Recognized Component Mark

Bruce Mahlenholz, Director North American Certification Program

UL LLC

Any information and documentation involving UL Mark services are provided on behalf of UL LLC, RUL or any authorized licensee of UL. For questions, please contact a local UL Customer Service Representative at <http://ul.com/aboutul/contact>

CERTIFICATE OF COMPLIANCE

Certificate Number E481791
Report Reference E481791-20210430
Issue Date 2021-APRIL-30

This is to certify that representative samples of the product as specified on this certificate were tested according to the current UL requirements.

***-80G-2, ***-80G-4, ***-80K-2, ***-90L-2, ***-90L-4, ***-90L-6, ***-90S-2, ***-90S-4, ***-90S-6, ***-100L-2, ***-100L-4, ***-100L-6, ***-100LX-4, ***-112M-2, ***-112M-4, ***-112M-6, ***-132M-4, ***-132M-6, ***-132MX-6, ***-132S-2, ***-132S-4, ***-132S-6, ***-132SX-2, ***-160L-2, ***-160L-4, ***-160L-6, ***-160LX-2, ***-160LX-4, ***-160LX-6, ***-160LY-2, ***-180L-4, ***-180L-6, ***-180M-2, ***-180M-4, ***-200L-2, ***-200L-4, ***-200L-6, ***-200LX-2, ***-200LX-6, ***-225M-2, ***-225M-4, ***-225M-6, ***-225S-4, ***-250M-2, ***-250M-4, ***-250M-6, ***-280M-2, ***-280M-4, ***-280M-6, ***-280S-2, ***-280S-4, ***-280S-6, ***-315L-2, ***-315L-4, ***-315L-6, ***-315LX-2, ***-315LX-4, ***-315LX-6, ***-315M-2, ***-315M-4, ***-315M-6, ***-315S-2, ***-315S-4, ***-315S-6, ***-355L-2, ***-355L-4, ***-355L-6, ***-355LX-2, ***-355LX-4, ***-355LX-6, ***-355LY-2, ***-355LY-4, ***-355LY-6, ***-355M-2, ***-355M-4, ***-355M-6, ***-355MX-6, ***-355MY-6, ***-400M-2, ***-400M-4, ***-400M-6.

****143T-2, ****143T-4, ****145T-2, ****145T-4, ****145T-6, ****182T-2, ****182T-4, ****182T-6, ****184T-2, ****184T-4, ****184T-6, ****213T-2, ****213T-4, ****213T-6, ****215T-2, ****215T-4, ****215T-6, ****254T-2, ****254T-4, ****254T-6, ****256T-2, ****256T-4, ****256T-6, ****284T-2, ****284T-4, ****284T-6, ****286T-4, ****286T-6, ****286TS-2, ****324T-4, ****324T-6, ****324TS-2, ****326T-4, ****326T-6, ****326TS-2, ****364T-4, ****364T-6, ****364TS-2, ****365T-4, ****365T-6, ****365TS-2, ****404T-8, ****405T-4, ****405T-6, ****405TS-2, ****444T-4, ****444T-6, ****444TS-2, ****445T-4, ****445T-6, ****445TS-2, ****447T-4, ****447T-6, ****447TS-2, ****449T-4, ****449T-6, ****449TS-2, ****504/5T-4, ****504/5T-6, ****586/7T-4, ****586/7T-6, FWMP 400LY-4.

Bruce Mahlenholz, Director North American Certification Program

UL LLC

Any information and documentation involving UL Mark services are provided on behalf of UL LLC, RUL or any authorized licensee of UL. For questions, please contact a local UL Customer Service Representative at <http://ul.com/aboutul/contact>





FELM IEC Electric Motors

GENERAL CHARACTERISTICS

The designing, manufacturing and testing of squirrel cage induction motors made by Felm® *are in according UL NEMA electrical design*, Felm supply high quality steel frame motors with high performance and flexibility to meet the customer request. The motors are widely used in various industries of mining, pumps, compressors, wind machineries, fans etc..

UL MOTORS, F-UL Serie:

Number of Poles: 2-4-6

Voltage: 460+-10%

Frequency: 60+-2%

Service factor: 1.15

Design: Nema A & B – IEC N

Frames: 80-355 (mm.)

(Options other frame)

80-132 Aluminium / 160-355 Cast iron housing

Cooling system: IC411(Inverter use rated 1:1)

(Options IC416)

Die casting Rotor

Shaft sealing:

O-Ring

Deep & Bake insulation

(option double impregnation VI)

Insulation class F (class B temperature rise)

Degree of protection IP55

(Options IP56 - IP65 – IP66)

Mounting: B3

(Options B3/B5-V1-B14)

Final colour: RAL 5010

(Options other types of colours)

Painting plan: C2

(Options C3-C4-C5-Marine-Chemical)

Internal epoxy coating

(Options tropicalization - humidity >95%)

Amb. temp.: -20°C/+40°C

(Options amb. up to -55°C)

Sintered drain plug

Terminal box : Top

(Options right or left)

Shaft Material: C45

(Options other types of materials)

Double grounding (1 inside terminal box + 1 on the frame)

Grease Caltex SRI-2 or SKF LGHP2

(Different types recommended by Felm)

Re-greasing devices ≥ 250 frame

Options:

Re-greasing system <250 frame

Space Heaters

PT100 windings and bearings

Transmitters

Vibration probes









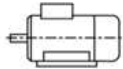
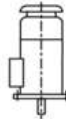

Junction box

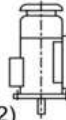
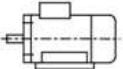
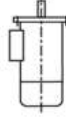
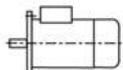
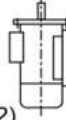
Predisposition and supply of all type of Encoder

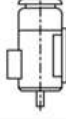
Special shaft materials

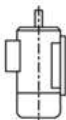
Insulated bearing >280 frame

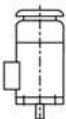
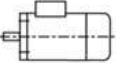
FRAME AND TYPE OF MOUNTING (IEC 60034-7)

Code I	Code II		Frame Size					Code I	Code II		Frame Size				
			63 ÷ 112	132	160 ÷ 250	280 ÷ 315	355 ÷ 400				63 ÷ 112	132	160 ÷ 250	280 ÷ 315	355 ÷ 400
IM B3	IM 1001	 1)	•	•	•	•	•	IM V1	IM 3011	 2)	•!	•	•	•	•
IM B35	IM 2001	 1) 2)	•	•	•	•	•	IM V15	IM 2011	 1) 2)	•!	•	•	•	•
IM B34	IM 2101	 1) 3)	•	•				IM V3	IM 3031	 2)	•	•	•	X	X
IM B5	IM 3001	 2)	•	•	•	X	X	IM V36	IM2031	 1) 2)	•	•	•	X	X
IM B6	IM 1051	 1)	•	•	•	X	X	IM V5	IM 1011	 1)	•!	•	•	X	X
IM B7	IM 1061	 1)	•	•	•	X	X	IM V6	IM 1031	 1)	•	•	•	X	X
IM B8	IM 1071	 1)	•	•	•	X	X	IM V18	IM 3611	 3)	•!	•			
IM B14	IM 3601	 3)	•	•				IM V19	IM 3631	 3)	•	•			

<p>1. Motors with feet</p> <p>2. Flanged Motor: unthreaded through holes</p> <p>3. Flanged Motor: threaded dead holes</p>	<p>•: Available</p> <p>X: Consult Felm</p> <p>!: Cast Iron Motors 63 frame without anti-rain canopy</p>
---	---

For other mountings refer to IEC 60034-7.

SERIES F-UL - Technical Data @ 60Hz

Electrical part according to NEMA MG1-2014 table 12-12

Motor Type	Rated Power		Rated Speed	Efficiency	Power Factor	Current		Torque			Moment of inertia(J) Kg-m ²	Approx WT Kg
	KW	(HP)				RPM	%	φ	FULL Load 460V	Locked Rotor		
			A	FLC	N-m				FLT	FLT		
F-UL 80K2	0,75	1,0	3414	77.0	0,89	1.37	7,5	2.09	2,2	2,3	0,0012	9
F-UL 80G2	1,1	1,5	3438	84.0	0,83	1.97	7,4	3.05	2,1	2,2	0,0014	9,5
F-UL 80G4	0,75	1,0	1692	85.5	0,75	1,46	7,3	4.23	2,3	2,3	0,0021	10,8
F-UL 90S2	1,5	2,0	3450	85.5	0,81	2.66	7,5	4.15	2,1	2,2	0,0029	12
F-UL 90L2	2,2	3,0	3438	86.5	0,84	3.8	7,5	6.11	2,2	2,3	0,0029	13,5
F-UL 90S4	1,1	1,5	1698	86.5	0,74	2,16	7,5	6.18	2,3	2,5	0,0023	12
F-UL 90L4	1,5	2,0	1704	86.5	0,77	2.83	7,6	8.04	2,4	2,5	0,0027	13,8
F-UL 90S6	0,75	1,0	1086	82.5	0,66	1.72	6,3	6.59	1,8	2,5	0,0029	12
F-UL 90L6	1,1	1,5	1092	87.5	0,65	2,4	6	9.61	1,8	2,5	0,0035	13,7
F-UL 100L4	2,2	2,9	1704	89.5	0,77	4,0	7,5	12.3	2,4	2,5	0,0054	21
F-UL 100L6	1,5	2,0	1110	88.5	0,69	3,1	6,8	12.9	2,0	2,5	0,0069	23
F-UL 112M2	3.7	5	3444	88.5	0.92	5.8	7,5	10.2	2,2	2,3	0,0126	28
F-UL 112M4	3.7	5	1734	89.5	0.83	6.3	7,6		2,4	2,5	0,0095	29,5
F-UL 112M6	2,2	3,0	1104	89.5	0,67	4.6	6,5	19.0	2,0	2,5	0,014	28,2
F-UL 132S2	5,5	7,5	3468	89.5	0,87	8.8	7,4	15.1	2,1	2,2	0,0377	39
F-UL 132SX2	7,5	10,0	3480	90.2	0,87	11.9	7,5	20.5	2,2	2,4	0,0499	44,5
F-UL 132S4	5,5	7,5	1752	91.7	0,77	9.8	7,5	29.9	2,3	2,5	0,0214	41
F-UL 132M4	7,5	10,0	1760	91.7	0,79	13.0	7,7	40.6	2,4	2,5	0,0296	47,5
F-UL 132M6	3,7	5	1134	89.5	0.71	7.31	6,2		2,1	2,5	0,0357	43
F-UL 132MX6	5.5	7,5	1158	91.0	0,70	10.9	6	45.3	2,0	2,5	0,0449	47,2
F-UL 160L2	11	15,0	3522	91.0	0,89	17.0	7	29,8	2,0	2,5	0,0510	125
F-UL 160LX2	15	20	3522	91.0	0,88	23.4	7,0	40.6	1,8	2,5	0,0637	136
F-UL 160LY2	18,5	25,0	3528	91,7	0,89	28.6	7,5	50.0	2,1	2,5	0,0765	148

On demand:

0,18KW – 0,25KW – 0,37KW – 0,55KW - 3KW – 4KW : Electric part according to IE2@60Hz Nema Epact table 12-11



SERIES F-UL - Technical Data @ 60Hz

Electrical part according to NEMA MG1-2014 table 12-12

Motor Type	Rated Power		Rated Speed RPM	Efficiency %	Power Factor φ	Current		Torque			Moment of inertia(J) Kg-m ²	Approx WT Kg
	KW	(HP)				FULL Load 460V A	Locked Rotor FLC	Full Load N·m	Locked Rotor FLT	Pull Out FLT		
F-UL 160L4	11	15	1770	92.4	0.84	17.8	7,5	59.3	2,0	2,5	0,1068	138
F-UL 160LX4	15	20	1770	93.0	0.83	24.3	7,8	80.9	2,0	2,5	0,1287	150
F-UL 160L6	7,5	10	1164	91.0	0.73	14.1	6,5	61.5	1,8	2,5	0,1170	120
F-UL 160LX6	11	15	1164	91.7	0.75	20.1	6,7	90.2	1,9	2,5	0,1775	144
F-UL 180M2	22	30	3540	91.7	0.89	33.7	7,9	59.3	2,3	2,5	0,1170	189
F-UL 180M4	18,5	25	1758	93.6	0.79	30.8	7	100	2,0	2,5	0,1901	186
F-UL 180L4	22	30	1764	93.6	0.81	36.2	7,5	119	2,1	2,5	0,2264	206
F-UL 180L6	15	20	1176	91.7	0.77	26.5	6,5	121	1,7	2,5	0,3158	201
F-UL 200L2	30	40	3552	92.4	0.88	46.4	7,4	80.6	2,0	2,5	0,1737	242
F-UL 200LX2	37	50	3552	93.0	0.87	57.2	7,6	99.4	2,1	2,5	0,2048	270
F-UL 200L4	30	40	1764	94.1	0.81	49.1	7,2	162	2,0	2,5	0,3612	269
F-UL 200L6	18.5	25	1176	93.0	0.77	32.5	7,2	150	1,9	2,5	0,4684	243
F-UL 200LX6	22	30	1176	93.0	0.77	38.5	7,2	178	1,9	2,5	0,5483	259
F-UL 225M2	45	60	3540	93.6	0.88	68.4	7,5	121	2,0	2,5	0,3020	328
F-UL 225S4	37	50	1764	94.5	0.82	59.6	7,6	200	2,2	2,5	0,6300	314
F-UL 225M4	45	60	1776	95.0	0.83	71.4	7,8	242	2,2	2,5	0,7384	356
F-UL 225M6	30	40	1182	94.1	0.80	49.6	7,2	242	2,0	2,3	0,8842	333
F-UL 250M2	55	75	3564	93.6	0.89	82.2	7,8	147	2,2	2,5	0,4077	414
F-UL 250M4	55	75	1776	95.4	0.85	85.2	7,2	296	2,2	2,5	1,0236	473
F-UL 250M6	37	50	1182	94.1	0.83	59.6	7,4	298	2,2	2,5	1,1968	410
F-UL 280S2	75	100	3570	94.1	0.90	112.6	7,5	200	2,0	2,5	0,7988	541
F-UL 280M2	90	125	3570	95.0	0.88	135.1	7,5	240	1,9	2,5	1,0708	645
F-UL 280S4	75	100	1782	95.4	0.84	117.1	7,5	401	2,2	2,5	2,0828	620
F-UL 280M4	90	125	1788	95.4	0.85	138.1	7,5	480	2,2	2,5	2,5457	673
F-UL 280S6	45	60	1188	94.5	0.83	71.4	7,4	362	2,2	2,5	2,3382	586
F-UL 280M6	55	75	1188	94.5	0.84	87.4	7,5	442	2,2	2,5	2,7975	665
F-UL 315S2	110	150	3564	95.0	0.90	160.6	7,5	295	2,0	2,5	2,0314	900
F-UL 315L2	150	200	3564	95.4	0.85	231	7,5	400	2,2	2,5	2,4867	1160

SERIES F-UL - Technical Data @ 60Hz

Electrical part according to NEMA MG1-2014 table 12-12

Motor Type	Rated Power		Rated Speed	Efficiency	Power Factor	Current		Torque			Moment of inertia(J)	Approx WT
	KW	(HP)				RPM	%	φ	FULL Load 460V	Locked Rotor		
			A	FLC	N·m				FLT	FLT	Kg·m ²	Kg
F-UL 315LX2	185	250	3558	95.8	0.93	289.2	7,3	537	1,8	2,5	2,9069	1250
F-UL 355M2	220	300	3558	95.8	0.90	326	7,5	596	1,9	2,5	3,0120	1300
F-UL 355L2	260	350	3558	95.8	0.90	380	7,5	696	1,9	2,5	3,213	1336
F-UL 355LX2	330	450	3558	95.8	0.90	480	7,5	885	1,9	2,5	4,463	1750
F-UL 355LY2	375	500	3558	95.8	0.90	546	7,5	1006	1,9	2,5	4,768	1870
F-UL 315S4	110	150	1782	95.8	0.86	166.3	7,0	589	2,1	2,5	3,4904	900
F-UL 315L4	150	200	1788	96.2	0.81	241	7,5	800	2,1	2,5	5,2356	1130
F-UL 315LX4	185	250	1788	96.2	0.91	295.5	7,5	1068	2,2	2,5	5,7010	1190
F-UL 355M4	220	300	1788	96.2	0.88	332	7,5	1194	2,0	2,5	7,456	1660
F-UL 355L4	260	350	1788	96.2	0.88	387	7,5	1397	2,0	2,5	9,297	1780
F-UL 355LX4	330	450	1788	95.8	0.88	492	7,5	1763	2,0	2,5	10,286	1865
F-UL 355LY4	375	500	1788	95.8	0.88	559	7,5	2003	2,0	2,5	11,275	1900
F-UL 315S6	75	100	1188	94.5	0.82	120.3	7,4	603	2,0	2,5	4,7411	860
F-UL 315M6	90	125	1188	95.0	0.84	141.7	7,6	724	2,0	2,5	5,8225	980
F-UL 315L6	110	150	1188	95.0	0.82	176	7,7	884	2,0	2,5	6,6542	1050
F-UL 355M6	150	200	1188	95.8	0.79	248	7,5	1206	1,8	2,5	10,3863	1670
F-UL 355MX6	185	250	1188	95.8	0.84	287	7,5	1478	1,8	2,5	10,8930	1720
F-UL 355L6	220	300	1188	95.8	0.85	308.6	7,5	1675	1,8	2,5	12,4130	1820
F-UL 355LX6	260	350	1188	95.8	0.85	339	7,5	1768	1,8	2,5	13,1729	1860
F-UL 355XA6	330	450	1188	95.8	0.85	509	7,5	2652	1,8	2,5	14,000	2410
F-UL 355XB6	375	500	1188	95.8	0.85	579	7,5	3015	1,8	2,5	15,000	2650

On demand:

132KW – 200KW – 280KW – 315KW - 355KW: Electric part according to IE2@60Hz Nema Epact table 12-11

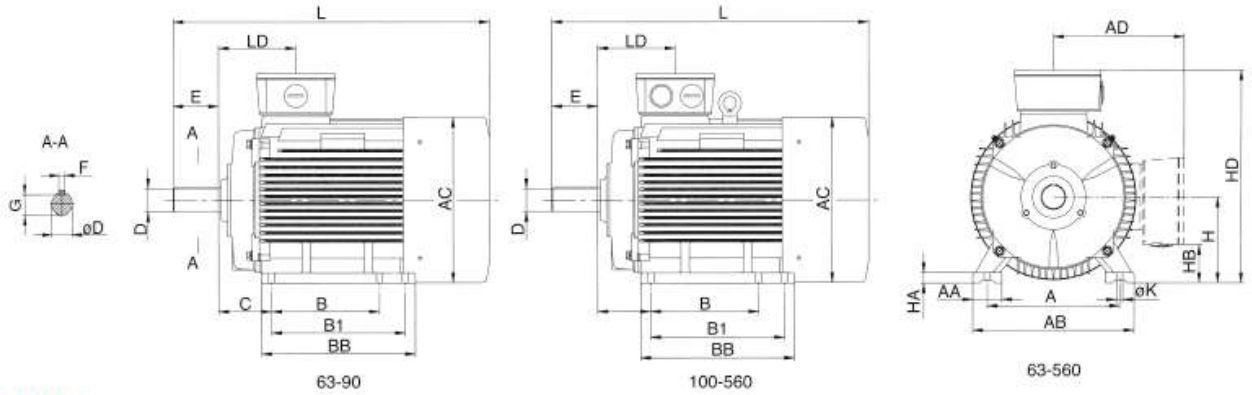

◆ B3

frame	Pole	Dimension								Dimension										
		A	B	B1	C	CA	H	K	AA	AB	AC	AD	BB	HA	HB	HB		LD	L	LC
																On top	L&R			
80	2-8	120	100	-	50	90	80° -0.5	10	30	100	100	140	130	12	30	220	100	70	200	330
90S	2-8	140	100	-	56	117	90° -0.5	10	36	180	180	155	140	12	50	245	180	75	315	373
90L	2-8	140	125	-	56	117	90° -0.5	10	36	180	180	155	165	12	50	245	180	75	340	373
100L	2-8	160	140	-	63	120	100° -0.5	12	40	200	200	180	175	14	55	280	200	83	375	443
112M	2-8	190	140	-	70	138	112° -0.5	12	45	230	220	190	180	15	60	305	222	87	400	468
132S	2-8	216	140	-	89	164	132° -0.5	12	55	265	260	220	190	18	65	355	262	102	465	553
132M	2-8	216	178	-	89	146	132° -0.5	12	55	265	260	220	230	18	65	355	262	102	505	593
160M	2-8	254	210	-	108	188	160° -0.5	15	65	315	315	265	260	20	81	425	385	146	608	726
160L	2-8	254	254	-	108	188	160° -0.5	15	65	315	315	265	305	20	81	425	385	146	652	770
180M	2.4	279	241	-	121	226	180° -0.5	15	70	350	360	280	315	22	105	460	420	161	690	808
180L	4-8	279	279	-	121	228	180° -0.5	15	70	350	360	280	350	22	105	460	420	161	730	848
200L	2-8	318	305	-	133	220	200° -0.5	19	70	390	400	310	370	25	85	510	475	186	760	878
225S	4-8	356	286	-	149	243	225° -0.5	19	75	435	450	335	370	28	110	555	535	189	810	928
225M	2	356	311	-	149	243	225° -0.5	19	75	435	450	335	395	28	110	555	535	189	805	923
	4-8	356	311	-	149	198	225° -0.5	19	75	435	450	335	395	28	110	555	535	189	835	953
250M	2	406	349	-	168	261	250° -0.5	24	80	485	485	375	445	30	110	625	570	207	910	1028
	4-8	406	349	-	168	261	250° -0.5	24	80	485	485	375	445	30	120	625	570	207	910	1028
280S	2	457	368	-	190	295	280° -1.0	24	85	545	550	405	490	35	142	685	660	215	985	1103
	4-8	457	368	-	190	315	280° -1.0	24	85	545	550	405	490	35	142	685	660	215	1005	1153
280M	2	457	419	-	190	289	280° -1.0	24	85	545	550	405	540	35	142	685	660	215	1030	1148
	4-8	457	419	-	190	319	280° -1.0	24	85	545	550	405	540	35	142	685	660	215	1060	1208
315S	2	508	406	-	216	426	315° -1.0	28	120	630	625	560	570	45	110	875	780	257	1180	1328
	4-8	508	406	-	216	426	315° -1.0	28	120	630	625	560	570	45	110	875	780	257	1210	1358
315M 315L	2	508	457	508	216	485	315° -1.0	28	120	630	625	560	680	45	110	875	780	257	1290	1438
	4-8	508	457	508	216	485	315° -1.0	28	120	630	625	560	680	45	110	875	780	257	1320	1498
355M	2	610	500	560	254	640	355° -1.0	28	120	730	700	615	750	52	110	970	830	284	1526	1674
	4-8	610	500	560	254	640	355° -1.0	28	120	730	700	615	750	52	110	970	830	284	1556	1734
355L	2	610	560	630	254	580	355° -1.0	28	120	730	700	615	750	52	110	970	830	284	1526	1674
	4-8	610	560	630	254	580	355° -1.0	28	120	730	700	615	750	52	110	970	830	284	1556	1734
400M 400L	2	686	710	-	280	698	400° -1.0	35	120	810	860	-	1100	45	-	1090	-	362	1850	2028
	4-8	686	710	-	280	733	400° -1.0	35	120	810	860	-	1100	45	-	1090	-	362	1925	2143

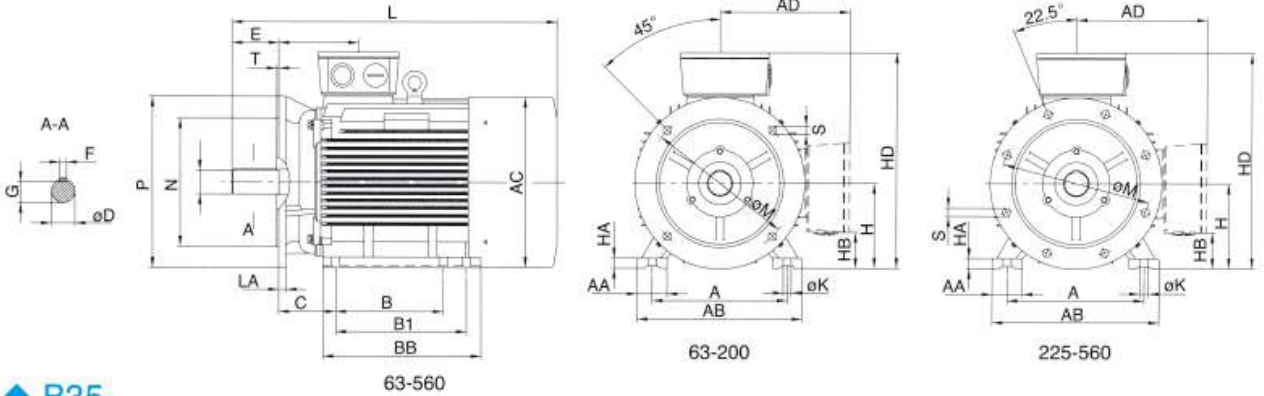

◆ B35

Frame	Poles	Dimension														Dimension											
		A	B	B1	C	CA	H	K	M	N	P	R	S	T	AA	AB	AC	AD	BB	HA	HB	HD		LA	LD	L	LC
		Top		L&R		LA		LD		L		LC															
80	2-8	125	100	-	50	98	80 ^{±0.5}	10	165	130	200	0	4-Ø12	4	35	160	160	145	130	12	36	225	160	12	75	280	336
90S	2-8	140	100	-	56	117	90 ^{±0.5}	10	165	130	200	0	4-Ø12	4	36	180	180	155	140	12	50	245	180	12	75	315	373
90L	2-8	140	125	-	56	117	90 ^{±0.5}	10	165	130	200	0	4-Ø12	4	36	180	180	155	165	12	50	245	180	12	75	340	373
100L	2-8	160	140	-	63	120	100 ^{±0.5}	12	215	180	250	0	4-Ø15	4	40	200	200	180	175	14	55	280	200	13	83	375	443
112M	2-8	190	140	-	70	138	112 ^{±0.5}	12	215	180	250	0	4-Ø15	4	45	230	220	190	180	15	60	305	222	14	87	400	468
132S	2-8	216	140	-	89	164	132 ^{±0.5}	12	265	230	300	0	4-Ø15	4	55	265	260	220	190	18	65	355	262	14	102	465	553
132M	2-8	216	178	-	89	146	132 ^{±0.5}	12	265	230	300	0	4-Ø15	4	55	265	260	220	230	18	65	355	262	14	102	505	593
160M	2-8	254	210	-	108	188	160 ^{±0.5}	15	300	250	350	0	4-Ø19	5	65	315	315	265	260	20	81	425	385	15	146	608	726
160L	2-8	254	254	-	108	188	160 ^{±0.5}	15	300	250	350	0	4-Ø19	5	65	315	315	265	305	20	81	425	385	15	146	652	770
180M	2.4	279	241	-	121	226	180 ^{±0.5}	15	300	250	350	0	4-Ø19	5	70	350	360	280	315	22	105	460	420	15	161	690	808
180L	4-8	279	279	-	121	228	180 ^{±0.5}	15	300	250	350	0	4-Ø19	5	70	350	360	280	350	22	105	460	420	15	161	730	848
200L	2-8	318	305	-	133	220	200 ^{±0.5}	19	350	300	400	0	4-Ø19	5	70	390	400	310	370	25	85	510	475	17	186	760	878
225S	4-8	356	286	-	149	243	225 ^{±0.5}	19	400	350	450	0	4-Ø19	5	75	435	450	335	370	28	110	555	535	20	189	810	928
225M	2	356	311	-	149	243	225 ^{±0.5}	19	400	350	450	0	8-Ø19	5	75	435	450	335	395	28	110	555	535	20	189	805	923
	4-8	356	311	-	149	198	225 ^{±0.5}	19	400	350	450	0	8-Ø19	5	75	435	450	335	395	28	110	555	535	20	189	835	953
250M	2	406	349	-	168	261	250 ^{±0.5}	24	500	450	550	0	8-Ø19	5	80	485	485	375	445	30	110	625	570	22	207	910	1028
	4-8	406	349	-	168	261	250 ^{±0.5}	24	500	450	550	0	8-Ø19	5	80	485	485	375	445	30	120	625	570	22	207	910	1028
280S	2	457	368	-	190	295	280 ^{±1.0}	24	500	450	550	0	8-Ø19	5	85	545	550	405	490	35	142	685	660	22	215	985	1103
	4-8	457	368	-	190	315	280 ^{±1.0}	24	500	450	550	0	8-Ø19	5	85	545	550	405	490	35	142	685	660	22	215	1005	1153
280M	2	457	419	-	190	289	280 ^{±1.0}	24	500	450	550	0	8-Ø19	5	85	545	550	405	540	35	142	685	660	22	215	1030	1148
	4-8	457	419	-	190	319	280 ^{±1.0}	24	500	450	550	0	8-Ø19	5	85	545	550	405	540	35	142	685	660	22	215	1060	1206
315S	2	508	406	-	216	426	315 ^{±1.0}	28	600	550	660	0	8-Ø24	6	120	630	625	560	570	45	110	875	780	22	257	1180	1328
	4-8	508	406	-	216	426	315 ^{±1.0}	28	600	550	660	0	8-Ø24	6	120	630	625	560	570	45	110	875	780	22	257	1210	1358
315M	2	508	457	508	216	485	315 ^{±1.0}	28	600	550	660	0	8-Ø24	6	120	630	625	560	680	45	110	875	780	22	257	1290	1438
	4-8	508	457	508	216	485	315 ^{±1.0}	28	600	550	660	0	8-Ø24	6	120	630	625	560	680	45	110	875	780	22	257	1320	1498
355M	2	610	500	560	254	640	355 ^{±1.0}	28	740	680	800	0	8-Ø24	6	120	730	700	615	750	52	125	970	830	25	284	1526	1674
	4-8	610	500	560	254	640	355 ^{±1.0}	28	740	680	800	0	8-Ø24	6	120	730	700	615	750	52	125	970	830	25	284	1556	1734
355L	2	610	560	630	254	580	355 ^{±1.0}	28	740	680	800	0	8-Ø24	6	120	730	700	615	750	52	125	970	830	25	284	1526	1674
	4-8	610	560	630	254	580	355 ^{±1.0}	28	740	680	800	0	8-Ø24	6	120	730	700	615	750	52	125	970	830	25	284	1556	1734
400M	2	686	710	-	280	698	400 ^{±1.0}	35	940	880	1000	0	8-Ø28	6	120	810	860	-	1100	45	-	1090	-	25	362	1850	2028
	4-8	686	710	-	280	733	400 ^{±1.0}	35	940	880	1000	0	8-Ø28	6	120	810	860	-	1100	45	-	1090	-	25	362	1925	2143

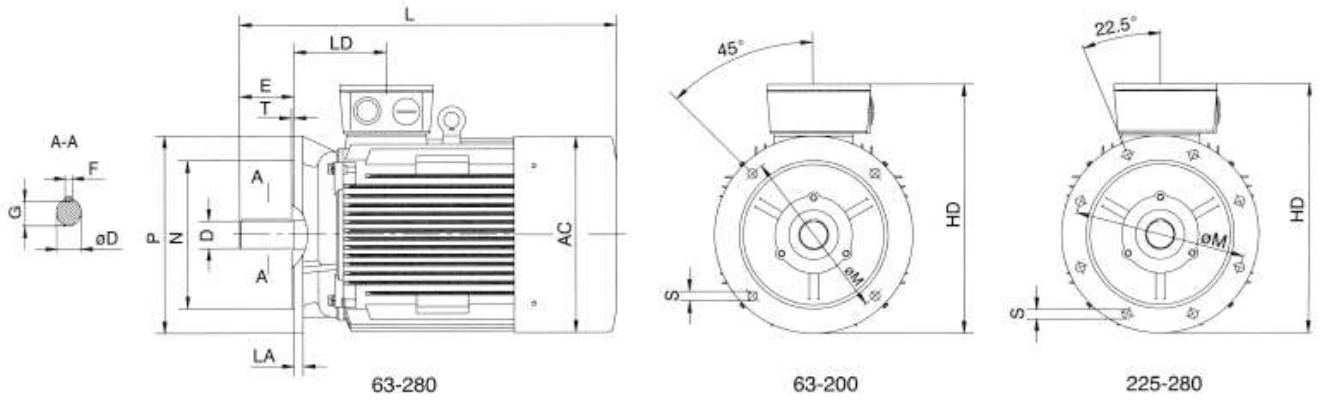

◆ B5

Frame	Pole	Dimension						Dimension					
		M	N	P	R	S	T	AC	AD	LA	LD	L	LC
80	2-8	165	130	200	0	4-ø12	4	160	145	12	75	280	336
90S	2-8	165	130	200	0	4-ø12	4	180	155	12	75	315	373
90L	2-8	165	130	200	0	4-ø12	4	180	155	12	75	340	373
100L	2-8	215	180	250	0	4-ø15	4	200	180	13	83	375	443
112M	2-8	215	180	250	0	4-ø15	4	220	193	14	87	400	468
132S	2-8	265	230	300	0	4-ø15	4	260	223	14	102	465	553
132M	2-8	265	230	300	0	4-ø15	4	260	223	14	102	505	593
160M	2-8	300	250	350	0	4-ø19	5	315	265	15	146	608	726
160L	2-8	300	250	350	0	4-ø19	5	315	265	15	146	652	770
180M	2.4	300	250	350	0	4-ø19	5	360	280	15	161	690	808
180L	4-8	300	250	350	0	4-ø19	5	360	280	15	161	730	848
200L	2-8	350	300	400	0	4-ø19	5	400	310	17	186	760	878
225S	4-8	400	350	450	0	8-ø19	5	450	330	20	189	810	928
225M	2	400	350	450	0	8-ø19	5	450	330	20	189	805	923
	4-8	400	350	450	0	8-ø19	5	450	330	20	189	835	953
250M	2	500	450	550	0	8-ø19	5	485	375	22	207	910	1028
	4-8	500	450	550	0	8-ø19	5	485	375	22	207	910	1028
280S	2	500	450	550	0	8-ø19	5	550	405	22	215	985	1103
	4-8	500	450	550	0	8-ø19	5	550	405	22	215	1005	1153
280M	2	500	450	550	0	8-ø19	5	550	405	22	215	1030	1148
	4-8	500	450	550	0	8-ø19	5	550	405	22	215	1060	1208

BEARINGS

B3 B35 B5 V1						
Frame size	Driving End			Non-driving End		
	2 pole	4 pole	>6 pole	2 pole	4 pole	>6 pole
80	6204ZZ	6204ZZ	6204ZZ	6204ZZ	6204ZZ	6204ZZ
90	6205ZZ/C3	6205ZZ/C3	6205ZZ	6205ZZ/C3	6205ZZ/C3	6205ZZ
100	6206ZZ/C3	6206ZZ/C3	6206ZZ/C3	6206ZZ/C3	6206ZZ/C3	6206ZZ/C3
112	6306ZZ/C3	6306ZZ/C3	6306ZZ/C3	6306ZZ/C3	6306ZZ/C3	6306ZZ/C3
132	6308ZZ/C3	6308ZZ/C3	6308ZZ/C3	6308ZZ/C3	6308ZZ/C3	6308ZZ/C3
160	6309ZZ/C3	6309ZZ/C3	6309ZZ/C3	6309ZZ/C3	6309ZZ/C3	6309ZZ/C3
180	6311ZZ/C3	6311ZZ/C3	6311ZZ/C3	6311ZZ/C3	6311ZZ/C3	6311ZZ/C3
200	6312ZZ/C3	6312ZZ/C3	6312ZZ/C3	6312ZZ/C3	6312ZZ/C3	6312ZZ/C3
225	6313ZZ/C3	6313ZZ/C3	6313ZZ/C3	6313ZZ/C3	6313ZZ/C3	6313ZZ/C3
250	6314C3	6314C3	6314C3	6314C3	6314C3	6314C3
280	6314C3	6317C3	6317C3	6314C3	6317C3	6317C3
315	6317C3	6319C3	6319C3	6317C3	6319C3	6319C3
355	6317C3	6322C3	6322C3	6317C3	6320C3	6320C3
400	6317C3	6326C3	6326C3	6317C3(7317B)	6326C3(7319B)	6326C3(7319B)

V1						
Frame size	Driving End			Non-driving End		
	2 pole	4 pole	>6 pole	2 pole	4 pole	>6 pole
315	6317C3	6319C3(NU319)	6319C3(NU319)	6317 (7317)	6319 (7317)	6319 (7319)
355	6319C3	6322C3(NU322)	6322C3(NU322)	6319 (7317)	6320 (7317)	6320 (7320)
400	6317C3	6326C3(NU326)	6326C3(NU326)	6319 (7317)	6326 (7317)	6326 (7326)

VIBRATION

Frame size	≤132		>132~225		>225~400	
	600~1800	>1800~3600	600~1800	>1800~3600	500~1800	>1800~3600
Synchronous Speed r/min						
Vibration Class	Effective Value of speed mm/s					
	1.8		2.8		3.5	
N						
R	0.71	1.12	1.12	1.80	1.80	2.80
S	0.45	0.71	0.71	1.12	1.12	1.80

SHAFT DIMENSION

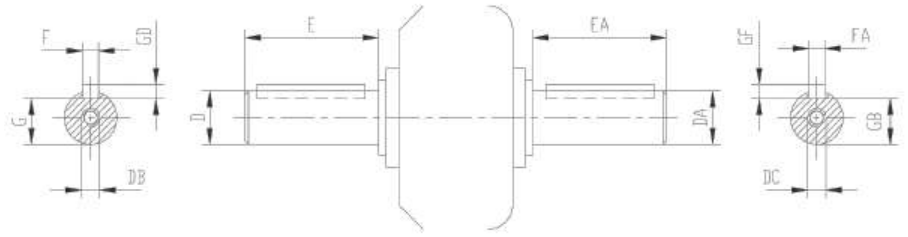

Frame	Pole	D	DA	E	EA	F	FA	G	GB	GD	GF	DB	DC
56	2-4	9 j6(+0.007/-0.002)	9 j6(+0.007/-0.002)	20	20	3	3	7	7	3	3	M3	M3
63	2-4	11 j6(+0.008/-0.003)	11 j6(+0.008/-0.003)	23	23	4	4	8.5	8.5	4	4	M4	M4
71	2-4-6	14 j6(+0.008/-0.003)	14 j6(+0.008/-0.003)	30	30	5	5	11	11	5	5	M5	M5
80	2-4-6-8	19 j6(+0.009/-0.004)	19 j6(+0.009/-0.004)	40	40	6	6	15.5	15.5	6	6	M6	M6
90S	2-4-6-8	24 j6(+0.009/-0.004)	24 j6(+0.009/-0.004)	50	50	8	8	20	20	7	7	M8	M8
90L	2-4-6-8												
100L	2-4-6-8	28 k6(+0.009/-0.004)	28 k6(+0.009/-0.004)	60	60	8	8	24	24	7	7	M10	M10
112M	2-4-6-8												
132S	2-4-6-8	38 k6(+0.018/-0.002)	38 k6(+0.018/-0.002)	80	80	10	10	33	33	8	8	M12	M12
132M	2-4-6-8												
160M	2-4-6-8	42 k6(+0.018/-0.002)	42 k6(+0.018/-0.002)	110	110	12	12	37	37	9	9	M16	M16
160L	2-4-6-8												
180M	2-4	48 k6(+0.018/-0.002)	48 k6(+0.018/-0.002)	110	110	14	14	42.5	42.5	9	9	M20	M20
180L	4-6-8												
200L	2	55 m6(+0.03/-0.011)	55 m6(+0.03/-0.011)	140	140	16	16	49	49	10	10	M24	M24
	4-6-8												
225S	4-6-8	60 m6(+0.03/-0.011)	60 m6(+0.03/-0.011)	140	140	18	18	53	53	11	11	M24	M24
225M	2	60 m6(+0.03/-0.011)	60 m6(+0.03/-0.011)	140	140	16	16	53	53	11	11	M24	M24
	4-6-8												
250M	2	65 m6(+0.03/-0.011)	65 m6(+0.03/-0.011)	140	140	18	18	58	58	11	11	M24	M24
	4-6-8												
280S	2	65 m6(+0.03/-0.011)	65 m6(+0.03/-0.011)	140	140	18	18	58	58	11	11	M24	M24
280M	2	75 m6(+0.03/-0.011)	75 m6(+0.03/-0.011)	140	140	20	20	67.5	67.5	12	12	M24	M24
	4-6-8												
315S	2	80 m6(+0.03/-0.011)	80 m6(+0.03/-0.011)	140	140	22	22	71	71	14	14	M24	M24
	4-6-8												
315M	2	65 m6(+0.03/-0.011)	65 m6(+0.03/-0.011)	140	140	18	18	58	58	11	11	M24	M24
315L	4-6-8	80 m6(+0.03/-0.011)	80 m6(+0.03/-0.011)	170	170	22	22	71	71	14	14	M24	M24
355M	2	75 m6(+0.03/-0.011)	75 m6(+0.03/-0.011)	140	140	20	20	67.5	67.5	12	12	M24	M24
	4-6-8												
355L	2	100 m6(+0.035/-0.013)	100 m6(+0.035/-0.013)	210	210	28	28	90	90	14	14	M24	M24
	4-6-8												
400M	2	80 m6(+0.03/-0.011)	80 m6(+0.03/-0.011)	170	170	22	22	71	71	14	14	M24	M24
400L	4-6-8	110 m6(+0.035/-0.013)	110 m6(+0.035/-0.013)	210	210	28	28	100	100	16	16	M24	M24

All data (technical, dimensions, etc..) listed in the tables are indicative and not binding. The guaranteed values are upon request. Felm srl reserves the right to change the project, the technical characteristics and dimensions at any time without previous notice.



CONTACTS

Head Quarter

FELM srl

Via Morandi (Industrial Area)

20010 Inveruno (Mi) Italy

Tel. +39 02 97 289 454

Tel. +39 02 97 288 320

Fax +39 02 97 289 923

E-mail home@felm.it

FELM Office Middle East

Jebel Ali Free Zone, Warehouse no. FZS1-BM07,

PO Box 263632, Dubai, United Arab Emirates

Office Ph. +971 (04) 887 9767

mobile +971 50 550 1322

Email: ayman.abdallah@felm.it

FELM Office Germany

Heinrich-Busold-Strasse 47

D-61169 Friedberg (Hessen), Germany

Tel (Off): +49-6031-721606

Mobile: +49-172-6729011

Fax: +49-6031-721610

Email: Jayant@jk-conrep.de

FELM Office China

Add: Room 1002, Building 3#,

No 139 Rd. SongShan,

Jianye, Nanjing, Jiangsu, China

Fax: +86-25-87797622

Tel: +86-15077829999

Email: lidongming1974@vip.sina.com

FELM Office UK

The Foundry, Wadebridge

Cornwall, PL27 7JP

United Kingdom

Tel (Off): +441208 816543

Email: sales@felm.co.uk

WORLD WIDE SERVICE

Mobile +39 355 69 53 804

E-mail service@felm.it





Electric Motors - www.felm.it



TRASFORMERS



Power and distribution transformers

Distribution transformers

Oil insulation	Power up to 2500 kVA	Voltage up to 72 kV
Resin insulation	Power up to 2500 kVA	Voltage up to 36 kV
Air insulation	Power up to 2500 kVA	Voltage up to 24 kV



OIL IMMERSED DISTRIBUTION TRANSFORMERS



CAST RESIN TRANSFORMERS



DRY TYPE DISTRIBUTION TRANSFORMERS

Power transformers

Oil insulation	Power up to 45 MVA	Voltage up to 170 kV
Resin insulation	Power up to 10 MVA	Voltage up to 36 kV
Air insulation	Power up to 7,5 MVA	Voltage up to 24 kV



OIL IMMERSED POWER TRANSFORMERS



CAST RESIN POWER TRANSFORMERS



CONTACTS

Head Quarter

FELM srl

Via Morandi (Industrial Area)

20010 Inveruno (Mi) Italy

Tel. +39 02 97 289 454

Tel. +39 02 97 288 320

Fax +39 02 97 289 923

E-mail home@felm.it

FELM Office Middle East

Jebel Ali Free Zone, Warehouse no. FZS1-BM07,

PO Box 263632, Dubai, United Arab Emirates

Office Ph. +971 (04) 887 9767

mobile +971 50 550 1322

Email: ayman.abdallah@felm.it

FELM Office Germany

Heinrich-Busold-Strasse 47

D-61169 Friedberg (Hessen), Germany

Tel (Off): +49-6031-721606

Mobile: +49-172-6729011

Fax: +49-6031-721610

Email: Jayant@jk-conrep.de

FELM Office China

Add: Room 1002, Building 3#,

No 139 Rd. SongShan,

Jianye, Nanjing, Jiangsu, China

Fax: +86-25-87797622

Tel: +86-15077829999

Email: lidongming1974@vip.sina.com

FELM Office UK

The Foundry, Wadebridge

Cornwall, PL27 7JP

United Kingdom

Tel (Off): +441208 816543

Email: sales@felm.co.uk

WORLD WIDE SERVICE

Mobile +39 355 69 53 804

E-mail service@felm.it

